

GateShare™ Latch

IDEAL FOR CONSTRUCTION SITES, UTILITY SITES, DRILLING SITES AND STORAGE AREAS

Patented

GATESHARE™ LATCH - MULTI-LOCK LATCH - SINGLE GATE

Part Number	Color	Post Size (in)	*Padlocks	Quantity/Weight
GSL-5-25POST-BK	Black	2.5	5	5/Case @ 46 lbs
GSL-5-25POST	Galvanized	2.5	5	5/Case @ 46 lbs
GSL-5-30POST-BK	Black	3	5	5/Case @ 46 lbs
GSL-5-30POST	Galvanized	3	5	5/Case @ 46 lbs
GSL-5-40POST-BK	Black	4	5	5/Case @ 46 lbs
GSL-5-40POST	Galvanized	4	5	5/Case @ 46 lbs
GSL-7-25POST-BK	Black	2.5	7	6/Case @ 53 lbs
GSL-7-25POST	Galvanized	2.5	7	6/Case @ 53 lbs
GSL-7-30POST-BK	Black	3	7	6/Case @ 53 lbs
GSL-7-30POST	Galvanized	3	7	6/Case @ 53 lbs
GSL-7-40POST-BK	Black	4	7	6/Case @ 53 lbs
GSL-7-40POST	Galvanized	4	7	6/Case @ 53 lbs
GSL-10-25POST-BK	Black	2.5	10	5/Case @ 48 lbs
GSL-10-25POST	Galvanized	2.5	10	5/Case @ 48 lbs
GSL-10-30POST-BK	Black	3	10	5/Case @ 48 lbs
GSL-10-30POST	Galvanized	3	10	5/Case @ 48 lbs
GSL-10-40POST-BK	Black	4	10	5/Case @ 48 lbs
GSL-10-40POST	Galvanized	4	10	5/Case @ 48 lbs

*Padlocks not included.

The gate latch for secured sites where multiple users need access

Remove any padlock and the gate can be opened

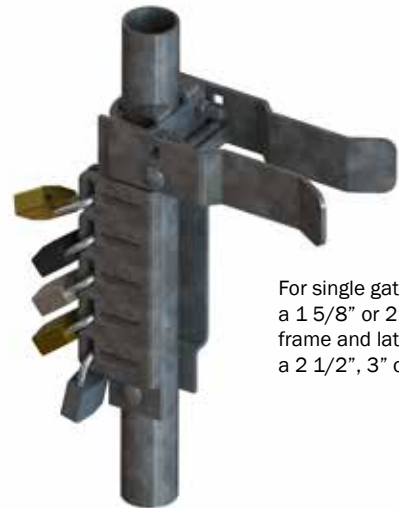

For single gates, fitting a 1 5/8" or 2" gate frame and latching on a 2 1/2", 3" or 4" post.

GATESHARE™ LATCH - MULTI-LOCK DOUBLE DRIVE LATCH

Part Number	Color	Post Size (in)	*Padlocks	Quantity/Weight
GSL-5-DD-BK	Black	1 5/8 or 2	5	5/Case @ 46 lbs
GSL-5-DD	Galvanized	1 5/8 or 2	5	5/Case @ 46 lbs
GSL-7-DD-BK	Black	1 5/8 or 2	7	6/Case @ 53 lbs
GSL-7-DD	Galvanized	1 5/8 or 2	7	6/Case @ 53 lbs
GSL-10-DD-BK	Black	1 5/8 or 2	10	5/Case @ 48 lbs
GSL-10-DD	Galvanized	1 5/8 or 2	10	5/Case @ 48 lbs

*Padlocks not included.

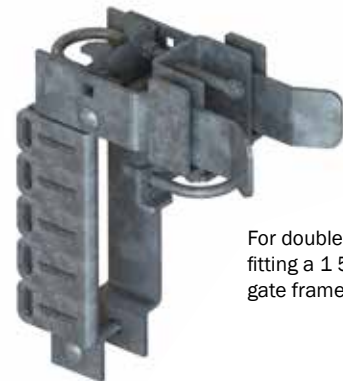

For double drive gates, fitting a 1 5/8" or 2" gate frames.



All padlocks must be used to have the latch locked



Total Lock-out Feature
Owner can lock out everyone



Individual Lock-out Feature
Owner can lock out anyone