

ECR/DCR		REV.		REVISIONS		DATE	APPD
-	-	-	-	DESCRIPTION	INITIAL RELEASE	11/9/17	-

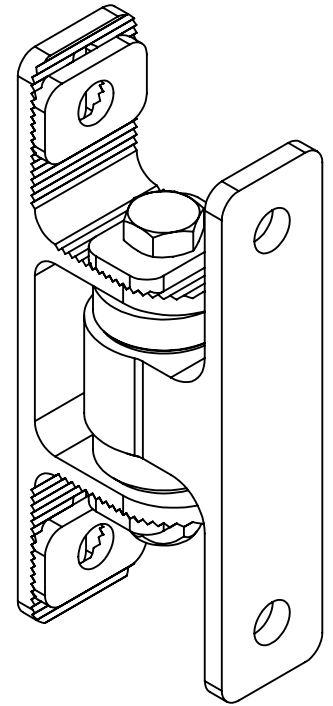
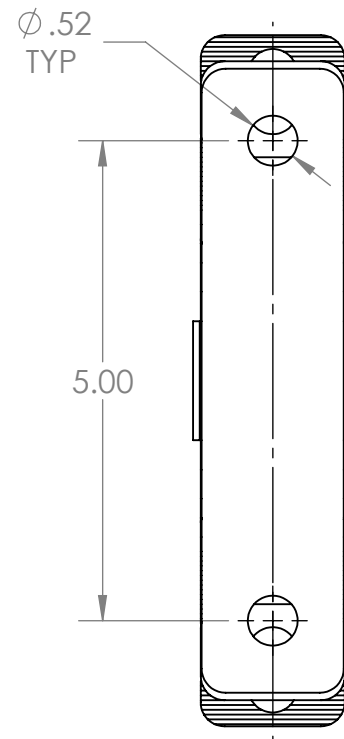
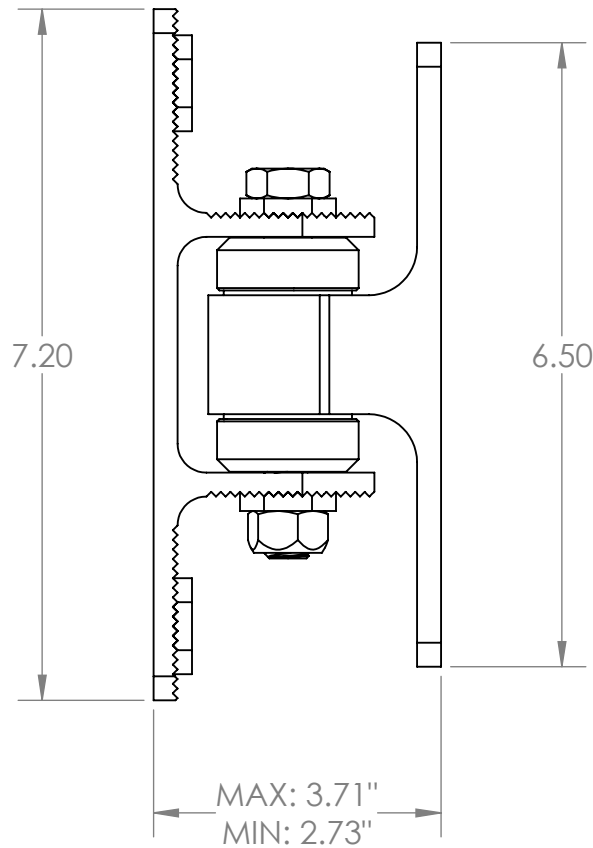
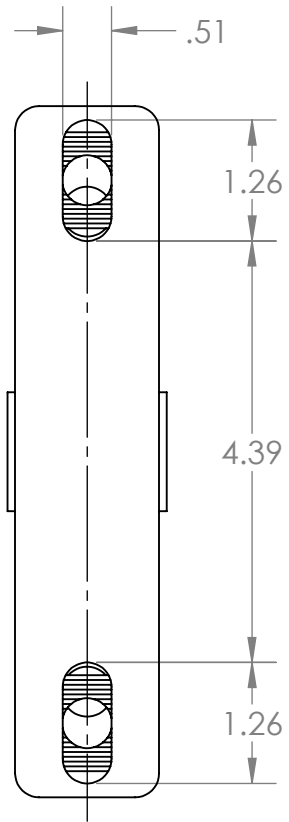
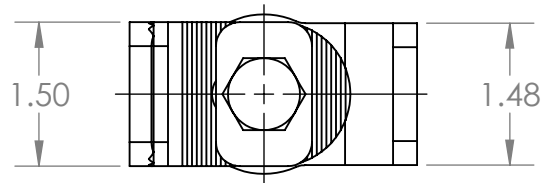

DIMENSIONS ARE IN INCHES
 TOLERANCES:
 FRACTIONAL $\pm 1/16$ "
 ANGULAR: MACH $\pm 1^\circ$ BEND $\pm 1^\circ$
 TWO PLACE DECIMAL ± 0.01
 THREE PLACE DECIMAL ± 0.005

PROPRIETARY AND CONFIDENTIAL
 THE INFORMATION CONTAINED IN THIS
 DRAWING IS THE SOLE PROPERTY OF
 NATIONWIDE INDUSTRIES. ANY
 REPRODUCTION IN PART OR AS A WHOLE
 WITHOUT THE WRITTEN PERMISSION OF
 NATIONWIDE INDUSTRIES IS PROHIBITED.

**NATIONWIDE
 INDUSTRIES**

**HEAVY DUTY HINGE
 "HDBY-ABB-ABB"
 OUTLINE & DIMENSIONS**

SIZE A	DWG. NO. CS--HDBY-ABB-ABB	REV. -
SCALE: 1:2	WEIGHT:	SHEET 1 OF 1