

ECR/DCR		REV.		REVISIONS		DATE	APPD
				DESCRIPTION			
-	-			INITIAL RELEASE		05-03-18	-

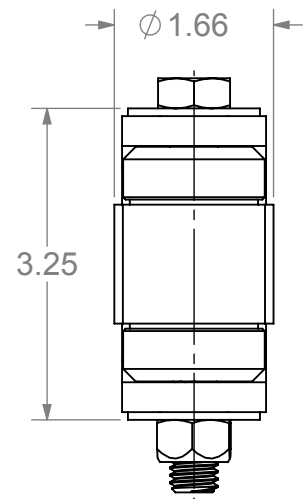

DIMENSIONS ARE IN INCHES  
TOLERANCES:  
FRACTIONAL  $\pm 1/16"$   
ANGULAR: MACH  $\pm 1^\circ$  BEND  $\pm 1^\circ$   
TWO PLACE DECIMAL  $\pm 0.01$   
THREE PLACE DECIMAL  $\pm 0.005$

**PROPRIETARY AND CONFIDENTIAL**  
THE INFORMATION CONTAINED IN THIS DRAWING IS THE SOLE PROPERTY OF NATIONWIDE INDUSTRIES. ANY REPRODUCTION IN PART OR AS A WHOLE WITHOUT THE WRITTEN PERMISSION OF NATIONWIDE INDUSTRIES IS PROHIBITED.

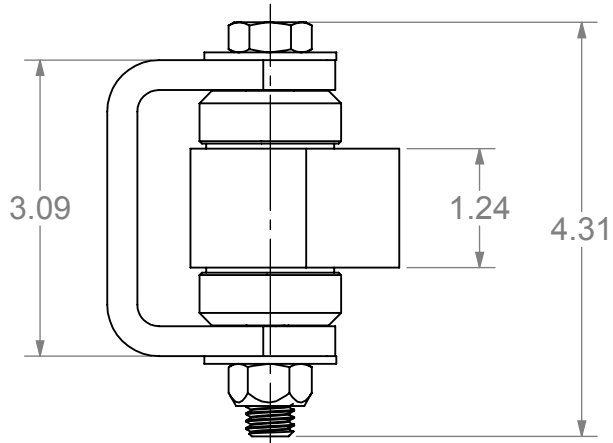
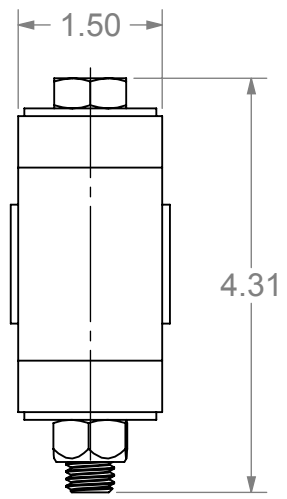
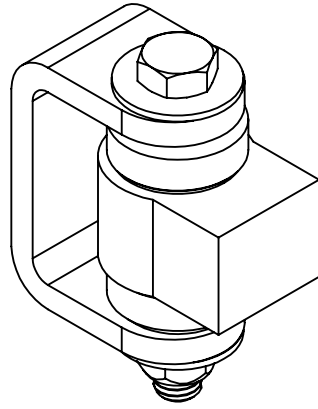
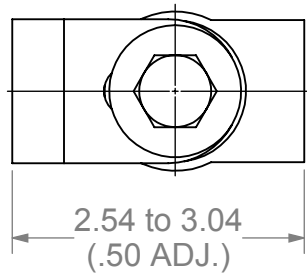
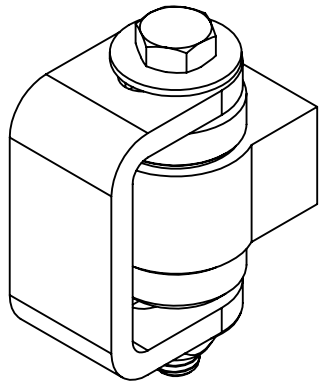

**'HDBY' HINGE  
ALUM WELD-ON BODY  
STEEL WELD ON YOKE**

SIZE: **A** DWG. NO. **CS--HDBY-AWM-SWM** REV. **--**  
SCALE: 1:2 WEIGHT: SHEET 1 OF 1