

PART #	FINISH
HDBY-SBB-ABB	BLACK
HDBY-SBM-ABM	MILL

REVISIONS		DESCRIPTION	DATE	APPD
ECR/DCR	REV.			
-	-	INITIAL RELEASE	06-15-17	-

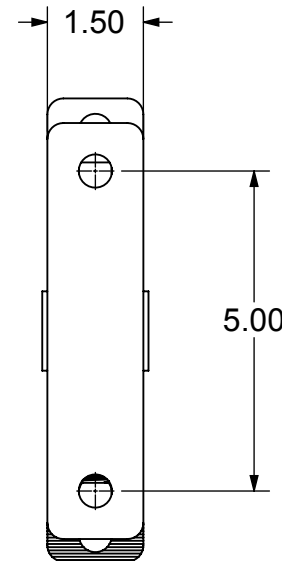
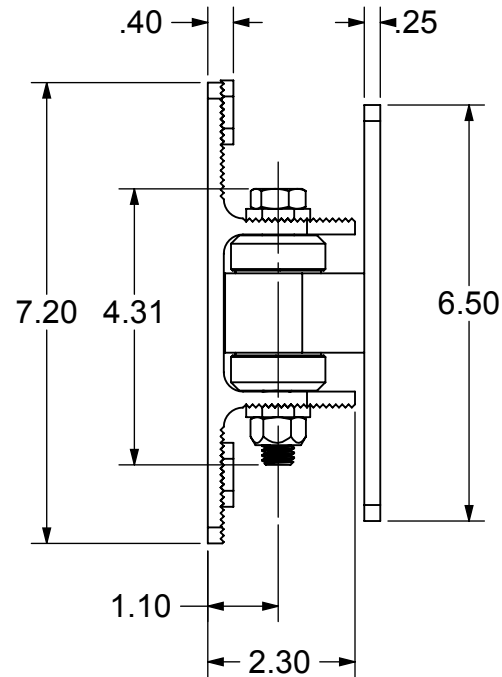
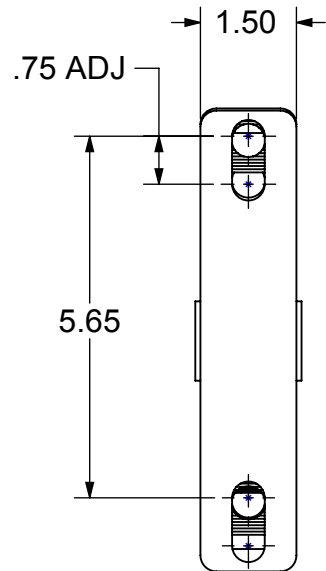
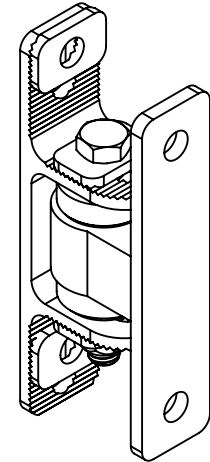
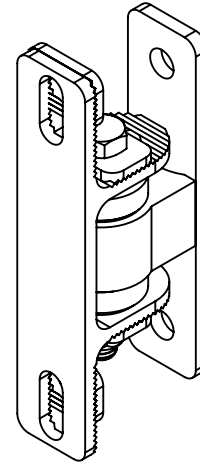
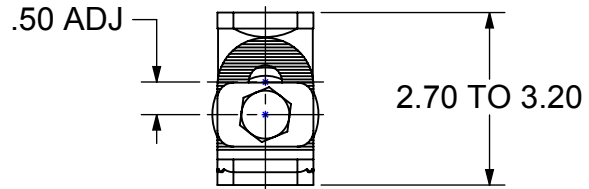

DIMENSIONS ARE IN INCHES
TOLERANCES:
FRACTIONAL $\pm 1/16$ "
ANGULAR: MACH ± 1 " BEND ± 1 "
TWO PLACE DECIMAL ± 0.01
THREE PLACE DECIMAL ± 0.005

PROPRIETARY AND CONFIDENTIAL
THE INFORMATION CONTAINED IN THIS DRAWING IS THE SOLE PROPERTY OF NATIONWIDE INDUSTRIES. ANY REPRODUCTION IN PART OR AS A WHOLE WITHOUT THE WRITTEN PERMISSION OF NATIONWIDE INDUSTRIES IS PROHIBITED.

NATIONWIDE INDUSTRIES

**HDBY HINGE
STEEL BOLT ON BODY
ALUM. BOLT ON YOKE**

SIZE **A** DWG. NO. **CS--HDBY-SB*-AB*** REV. **-**
SCALE: 1:3 WEIGHT: SHEET 1 OF 1