

ECR/DCR		REV.		REVISIONS		DATE	APPD
				DESCRIPTION			
-	-	-	-	INITIAL RELEASE		09-19-17	-

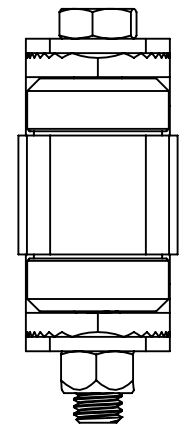

DIMENSIONS ARE IN INCHES
 TOLERANCES:
 FRACTIONAL $\pm 1/16"$
 ANGULAR: MACH $\pm 1^\circ$ BEND $\pm 1^\circ$
 TWO PLACE DECIMAL ± 0.01
 THREE PLACE DECIMAL ± 0.005

PROPRIETARY AND CONFIDENTIAL
 THE INFORMATION CONTAINED IN THIS DRAWING IS THE SOLE PROPERTY OF NATIONWIDE INDUSTRIES. ANY REPRODUCTION IN PART OR AS A WHOLE WITHOUT THE WRITTEN PERMISSION OF NATIONWIDE INDUSTRIES IS PROHIBITED.

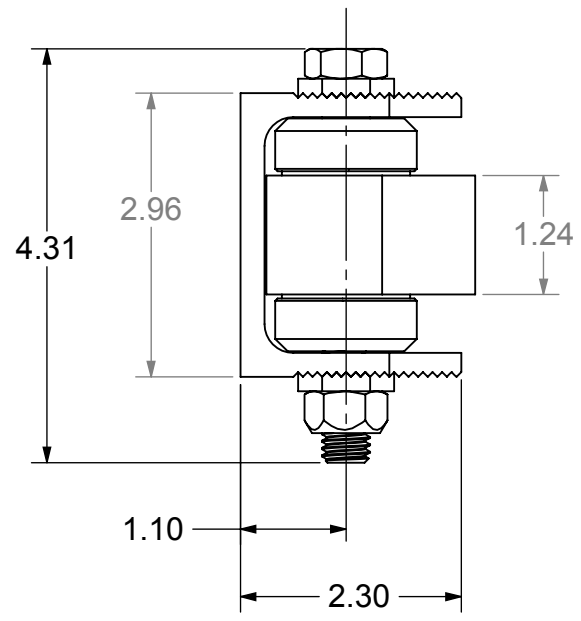
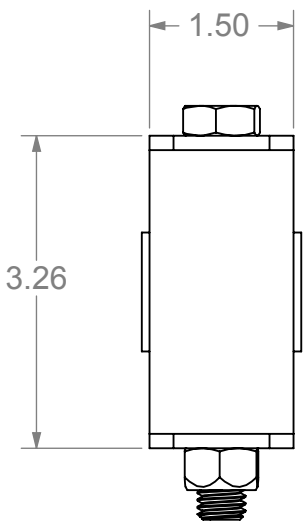
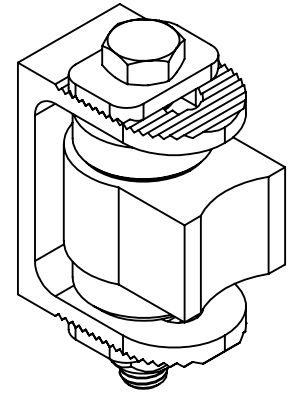
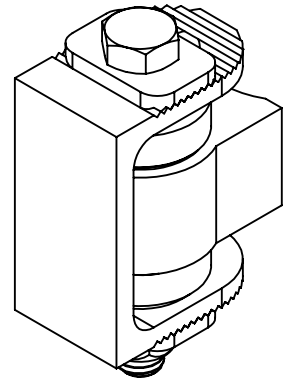
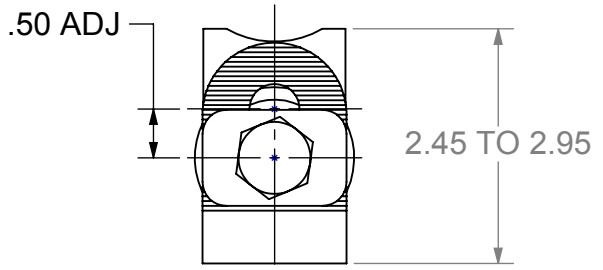

HDBY HINGE
STEEL WELD-ON BODY
ALUM. WELD-ON YOKE

SIZE: **A** DWG. NO. **CS--HDBY-SWM-AWM** REV. **-**
 SCALE: 1:2 WEIGHT: SHEET 1 OF 1