

Part No.	DESCRIPTION	COLOR	SCREW KIT P/N
KLADV-M2-BK	LATCH SET w/ STD SCREWS	BLACK	KL2SPACK-SS-B
KLADV-M2-WH	LATCH SET w/ STD SCREWS	WHITE	KL2SPACK-SS-W
KLADV-M2ZD-BK	LATCH SET w/ SELF DR. SCREWS	BLACK	KL2SPACK-STL-B
KLADV-M2ZD-WH	LATCH SET w/ SELF DR. SCREWS	WHITE	KL2SPACK-STL-W

ECR/DCR		REV.	REVISIONS DESCRIPTION	DATE	APPD
-	1		ADDED PART #'s, MATERIAL AND PACKAGING	2/27/14	-
-	-		-	-	-

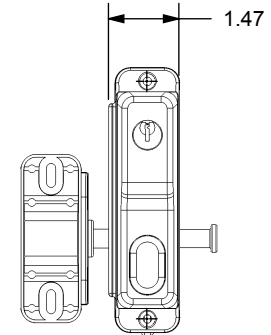
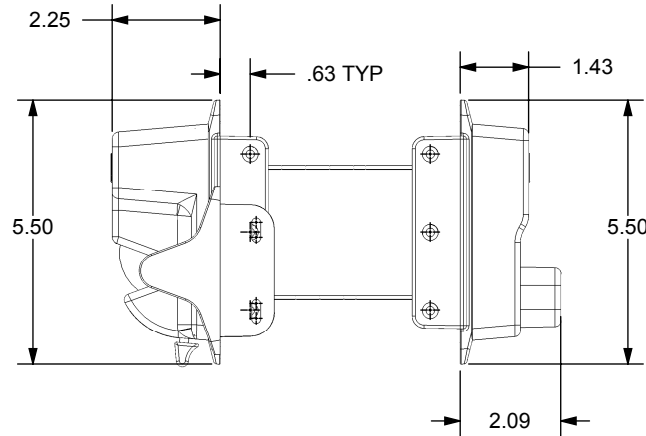
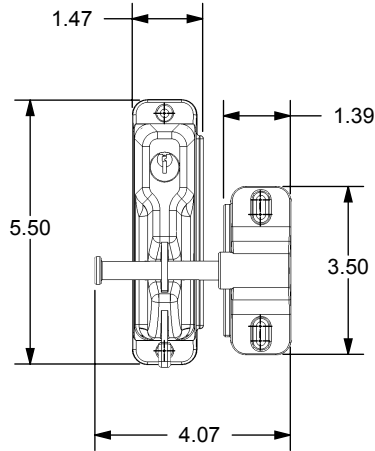
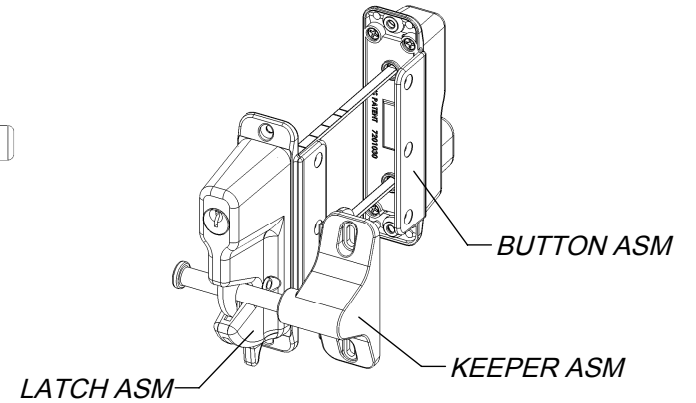
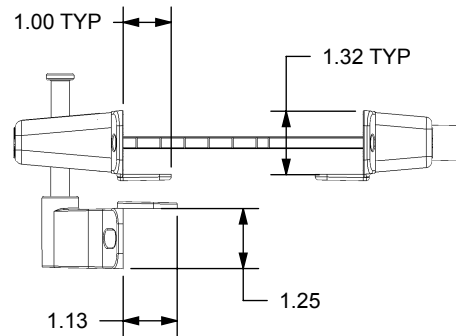

**PACKAGING INSTRUCTIONS:**  
BOX (20) SETS PER CARTON.

**PART No: KLADV-M2-\***  
\* COLOR CODE: W = WHITE; B = BLACK

- POLYBAGGED SET CONTAINS:**
- (1) MOUNTING HARDWARE KIT - POLYBAGGED CONTAINING:
    - (4) #8 x 3/4" PHILIPS PANHEAD SS SCREW
    - (10) #8 x 3/4" PHILIPS FLATHEAD SS SCREW
  - (1) LATCH ASSEMBLY - POLYBAGGED
  - (1) BUTTON ASSEMBLY - POLYBAGGED
  - (1) KEEPER ASSEMBLY - POLYBAGGED
  - (1) INSTRUCTION SHEET
  - (1) WARRANTY SHEET
  - (1) MOUNTING TEMPLATE
  - (2) PLASTIC SPINDLE COVER TUBES

**PART No: KLADV-M2ZD-\***  
\* COLOR CODE: W = WHITE; B = BLACK

- POLYBAGGED SET CONTAINS:**
- (1) MOUNTING HARDWARE KIT - POLYBAGGED CONTAINING:
    - (4) #8 x 3/4" PHILIPS PANHEAD SELF DRILLING STEEL SCREW
    - (10) #8 x 3/4" PHILIPS FLATHEAD SELF DRILLING STEEL SCREW
  - (1) LATCH ASSEMBLY - POLYBAGGED
  - (1) BUTTON ASSEMBLY - POLYBAGGED
  - (1) KEEPER ASSEMBLY - POLYBAGGED
  - (1) INSTRUCTION SHEET
  - (1) WARRANTY SHEET
  - (1) MOUNTING TEMPLATE
  - (2) PLASTIC SPINDLE COVER TUBES

HOUSING MATERIAL: ZAMAK 3

DIMENSIONS ARE IN INCHES TOLERANCES: FRACTIONAL ±1/16" ANGULAR: MACH ±1° BEND ±1° TWO PLACE DECIMAL ±0.01 THREE PLACE DECIMAL ±0.005		
PROPRIETARY AND CONFIDENTIAL THE INFORMATION CONTAINED IN THIS DRAWING IS THE SOLE PROPERTY OF NATIONWIDE INDUSTRIES. ANY REPRODUCTION IN PART OR AS A WHOLE WITHOUT THE WRITTEN PERMISSION OF NATIONWIDE INDUSTRIES IS PROHIBITED.		
SIZE DWG. NO. <b>CS--KLADV-M2</b> REV. <b>1</b>		KEYSTONE ADVANTAGE GENERAL ASSY & DETAILS
SCALE: 1:4	WEIGHT: LB.	SHEET 1 OF 1