



Towable Hydraulic Earth Drill

OPERATORS MANUAL
WITH MAINTENANCE AND PARTS INFORMATION

1.800.227.7515
LITTLEBEAVER.COM



LITTLE BEAVER®
EARTH DRILLS & AUGERS

MFG BY: Little Beaver, Inc. 0318

P.O. Box 840, Livingston, Texas 77351
Phone: 936.327.3121 Fax: 936.327.4025
littlebeaver.com sales@littlebeaver.com

CUSTOMER SERVICE

Ph: 800/227-7515 or 936/327-3121 or Fax 936/327-4025

ORDERS...

Place your orders by telephone, fax, or mail. When calling, please have your parts manual handy for reference. Our hours are 8:00 am - 4:30 pm central time, Monday thru Friday. When ordering by mail or fax, include a description and LITTLE BEAVER part number for the items you are ordering, your return address, and payment or your authorization for COD shipment.

All orders are shipped UPS where possible. Freight charges will be added to your invoice. Some items are oversize, resulting in a higher shipping cost. Power units and larger augers are shipped via motor freight due to their weight.

PAYMENT TERMS...

COD, Cash in Advance, Visa, Mastercard or NET 30 with approved credit. COD limit for new accounts is \$500.00. Personal or company checks on new accounts will be held until they clear the bank. To eliminate this delay, you may pay by wire transfer or send a certified or cashiers check. For a NET 30 open account, please call or write for a credit application.

SERVICE AND REPAIR...

Your LITTLE BEAVER Earth Drill has been designed for user repair with ordinary hand tools. No special tools are required. Consult the appropriate section of the parts manual for instructions.

Service or technical consultation is available, free of charge, from the factory in Livingston, Texas. We will be pleased to help you with any problems or questions. Just write, fax, or call. Our hours are 8:00am - 4:30pm central time, Monday thru Friday.

Factory repair is available. If you return a part to the factory, please include the following information: Your name and return address, a description of the problem and payment or authorization to return the repaired item COD for the repair and shipping charges.

RETURNS...

Please call the factory for a return authorization. This will help to ensure that your parts are handled properly. Include your name and address, customer account #, invoice # under which the returned parts were ordered, and a brief description of the problem with the parts or the reason for returning them. Parts to be considered for warranty must be returned to the factory for inspection within 10 days after receipt of replacement parts. Be sure to prepay the shipping charges, we will not accept collect or COD packages.

Our mailing address...

LITTLE BEAVER, Inc.

2009 South Houston

P. O. Box 840

Livingston, Texas 77351



SAFETY ALERT SYMBOL



The symbol shown above is used to call your attention to instructions concerning your personal safety. **WATCH THIS SYMBOL** — It points out important safety precautions. It means — **ATTENTION! BECOME ALERT! YOUR PERSONAL SAFETY IS INVOLVED!**

Read the message that follows and be alert to the possibility of *Personal Injury or Death!*

WARNING: The Engine Exhaust from this product contains chemicals known to the State of California to cause cancer, birth defects or other reproductive harm.

2 YEAR LIMITED WARRANTY

For 2 years from purchase, LITTLE BEAVER, INC. will replace for the original purchaser, free of charge, any part or parts, found upon examination by any factory authorized service center, or by the factory at Livingston, Texas, to be defective in material or workmanship or both. If your equipment can not be repaired, it will be replaced. All transportation charges on parts submitted for replacement under this warranty must be borne by purchaser.

There is no other express warranty.

Implied warranties, including those of merchantability and fitness for a particular purpose, are limited to 2 years from purchase and to the extent permitted by law. Any and all implied warranties are excluded. This is the exclusive remedy and liability for consequential damages under any and all warranties are excluded to the extent exclusion is permitted by law.

*Notice: Engines are warranted by the manufacturer of the engine. See separate engine warranty enclosed.

MACHINE SERIAL NUMBER

The serial number is located on the top side of the frame. For your convenience, when requiring service or parts information, refer to this number and your model number. Record the serial number, model number, engine make and date of purchase in the space provided below:

Serial Number: _____

Model Number: _____

Engine Make: _____

Date of Purchase: _____



TABLE OF CONTENTS

OPERATORS MANUAL

Page #	
O-1	Safety Alert, Warranty and Machine Information
O-2	Table of Contents
O-3	Safety Instructions and Specifications
O-4	Maintenance and Lubrication Instructions
O-5	Set-up, Handle Adjustments
O-6	Set-up, Drive head and Actuator Adjustments
O-7	Towing Instructions
O-8, O-9 & O-10	Operation
O-11	Decal Location

PARTS MANUAL

Page #

P-2 & 3	Engine Frame Assembly
P-4 & 5	Spine and Valve Assembly
P-6 & 7	Head, Neck & Motor Assembly
P-8 & 9	Handle and Rock Shaft Linkage Assembly
P-10	Hydraulic Tank Assembly
P-11	Hitch and Wheel Breakdown

Hydraulic Notes

Prices for Hydraulic Parts and Augers

Inside Back Cover...Torque Information and Conversion Chart



SAFETY INSTRUCTIONS



DANGER: Failure to observe safety instructions and reasonable safety practices can cause Property Damage, Serious Bodily Injury and/or Death. BE CAREFUL!! WATCH OUT FOR BYSTANDERS!!



DANGER: NEVER run engine inside building or enclosed area. Exhaust gases contain carbon monoxide, an odorless and deadly poison.



DANGER: NEVER drill holes where there is a possibility of underground power cables or other hazards. The exact location of underground services must be determined prior to drilling. Inadvertent severing of telephone, fiber optic or CATV transmission cable, or damage to sewer pipe is costly; RUPTURING OF GAS OR WATER LINES CAN CAUSE SERIOUS BODILY INJURY AND/OR DEATH. COMING INTO CONTACT WITH BURIED POWER LINES CAN CAUSE SERIOUS BODILY INJURY, SEVERE BURNS, AND/OR ELECTROCUTION. Call local utility companies or your local "One-Call" number at least 48 hours before digging and have underground utilities marked.



DANGER: NEVER tow at a rate of speed greater than 25 mph. Adjust coupler to 2" ball only. Properly install safety chains.



WARNING: NEVER use hands to search for leaks. Instead, use a piece of cardboard or wood. Escaping hydraulic fluid under pressure can have sufficient force to penetrate the skin, causing serious injury. Before disconnecting lines, be sure to relieve pressure. Before applying pressure, be sure connections are tight and fittings and hoses are not damaged.



WARNING: Augers are not to be used as anchoring devices.



WARNING: ALWAYS store with hitch down on the ground to avoid accidental tipping which may cause serious injury or death.



CAUTION:

1. READ and understand this operator's manual and the operator's manual for the engine.
2. NEVER Remove auger from hole while auger is turning.
3. NEVER Operate auger at less than full throttle.
4. NEVER Operate drill with damaged auger or other damaged or missing parts.
5. KEEP Hands, Feet and Clothing away from moving parts while engine is running.
6. KEEP All safety shields and devices in place.
7. MAKE Certain everyone is clear before operating the machine.
8. WEAR SAFETY GLASSES.
9. KEEP Bystanders away from work area.
10. SHUT OFF Engine to adjust, service or clean the machine.
11. KEEP the SMV identification sign clean. The SMV identification sign must be replaced if it becomes faded or damaged.

NOTICE

It is the responsibility of the contractor, owner and user to maintain and operate the Earth Drill in compliance with operating instructions provided. Observe all listed safety instructions and other reasonable safety practices. LITTLE BEAVER, INC. accepts no responsibility for damages to this machine, and other property damage and/or bodily injury due to careless or improper operations.

LITTLE BEAVER, INC. does not recommend use of replacement hydraulic motors which would result in auger shaft torque greater than 400 ft.-lbs. If greater torque is required, please consult factory.

LITTLE BEAVER, INC. reserves the right to make changes in design and changes for improvements upon its product without imposing any obligation upon itself to install the same upon its products theretofore manufactured.

Your operators manual offers recommendations for prolonged and satisfactory service.

SPECIFICATIONS

11 HP Honda
6 GPM @ 2500 PSI
100 Micron Suction Screen
10 Micron Replaceable Return Line Filter
6 1/2 Gallon Hydraulic Reservoir



MAINTENANCE AND LUBRICATION INSTRUCTIONS

NOTE: All engines and hydraulic reservoirs are shipped WITHOUT oil.

ENGINE: The engine is shipped without oil or gasoline. Refer to the manufacturers instructions for proper procedures and recommended fluid.

HYDRAULIC FLUID AND FILTER: The hydraulic reservoir should be filled to the top of the sight gauge with hydraulic oil before attempting to start the engine. Most premium grade, mineral based oil with anti-wear (AW) and anti-foaming additives are suitable. The recommended fluid for normal temperature operation is ISO VG 46 grade fluid. In colder climates use ISO VG 32 grade and in warmer climates use ISO VG 68 grade fluid. The hydraulic oil and return line filter (Part # 30280) must be kept clean at all times, and should be changed after the first 15 hours of operation. The filter and oil should be changed every three months or after 100 hours of operation; whichever comes first. See Figure 1.

NOTE: The hydraulic fluid and engine crankcase oil levels should be checked prior to each days use.

IMPORTANT: All nuts, fasteners, and fittings must be kept tightened.



CAUTION: Escaping hydraulic fluid under pressure can have sufficient force to penetrate the skin, causing serious injury. Before disconnecting hydraulic lines, be sure to relieve pressure. Before applying pressure, be sure connections are tight and fittings, pipes and hoses are not damaged. Use a piece of cardboard or wood, rather than hands, to search for leaks. If injured by escaping fluid, see a doctor at once. Serious infection or reaction can develop if proper medical treatment is not administered immediately.



KEEP all hydraulic lines away from moving parts.

HYDRAULIC OIL LEAKAGE

If any hydraulic oil leakage is encountered, shut down the power source and relieve the hydraulic pressure by moving the actuator lever in both directions. Check and tighten the screw-on fittings on the end of each hose. If the leakage persists, it may be necessary to replace the associated hose assembly. If the valve is leaking around the spool (shaft), you may replace the seal kit (Part # 30275-2).

NOTE: To obtain maximum performance from power source, minimum hose size recommended is 3/8".

EXCESSIVE HEATING

Excessive heating is caused by placing too much down pressure on the auger which causes the oil pressure to reach relief pressure. Oil flowing over the relief valve generates the heat.

WHEEL BEARINGS

The wheel bearings should be checked annually for excessive end play and proper lubrication. To remove end play, remove the hub cap and cotter key from the slotted nut. Tighten the slotted nut until there is a definite resistance to wheel rotation, then back off one slot and install a new cotter key. Apply wheel bearing grease generously to wheel bearings as needed.

DECAL LOCATION

The decals which are provided with your machine are shown at the rear of this manual. The decals shown should be in the locations as described. If any of the decals are missing or illegible, order replacement decal kit # 37200-D# and install before operating the machine.



Figure 1



ASSEMBLY

Attach the slow moving vehicle (SMV) emblem bracket to be rear of the frame using (2) 5/16" x 1" hex bolts and nuts provided. (See SMV emblem picture on Page O-11)

 **WARNING:** ALWAYS tow with the slow moving vehicle (SMV) emblem properly installed.

SET-UP, Handle Adjustments

THREE POSITION HANDLE: The handle may be pivoted 180 degrees and locked into one of three positions. The handle is shown in the rearward position in Figure 2. To pivot the handle to the forward position, push and hold in both handle lock levers as shown in Figure 2. Then, pivot the handle approximately 90 degrees, release the lock levers, and lower the handle to the forward position as shown in Figure 3. By releasing the lock levers, the lock levers will lock the handle into position. Use the previously described procedure to pivot the handle from the forward position to the rearward position. The third position is near the forward position. This position allows for full penetration of the auger into the soil.



Figure 2
Handle in Rearward Position



Figure 3
Handle in Forward Position

HANDLE SIDE-TO-SIDE ADJUSTMENT: The handle may be swiveled up to 20 degrees to each side. Figure 4 shows the handle in the center position with the swivel lock screw tightened and the handle pinned. (Note: The center position is the only position which is pinned). To swivel the head side-to-side, remove the pin and store in the bushing provided, loosen the swivel lock screw by turning counter-clockwise, swivel the handle to desired position, tighten the swivel lock screw by turning

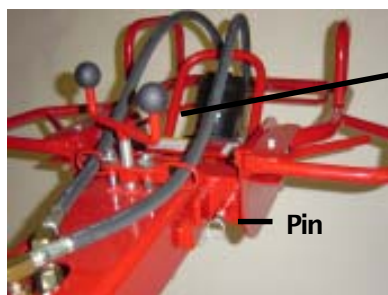

Figure 4
Handle in Center Position

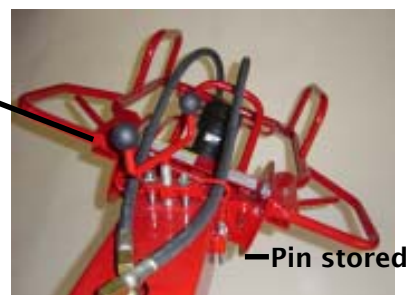

Figure 5
Handle in a Side Position



SET-UP, Adjustments cont...

DRIVE HEAD LOCK: The drive head may be locked in storage position or unlocked and allowed to swivel freely. Figure 6 shows the drive head in the locked (stored) position. To unlock the drive head, move the head lock lever to the outside, grasp the drive head handle, and pivot the drive head toward the level position. Figure 7 shows the drive head in the unlocked position where the head is allowed to swivel freely. To lock the drive head in storage position, pivot the drive head, using the drive head handle, into the position shown in Figure 6 and the head will lock into position.

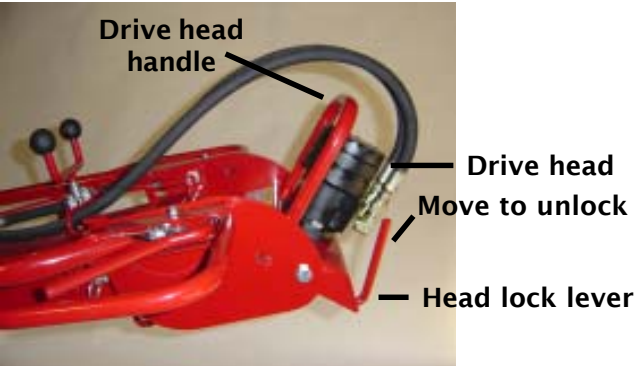

Figure 6
Drive head in locked (stored) position



Figure 7
Drive head in unlocked position

ACTUATOR LEVER ADJUSTMENT: The actuator lever link may need to be adjusted if the lever develops an unequal amount of motion for forward and reverse actuation. The actuator lever link may be adjusted by loosening the stop nut from the clevis, disconnecting the clevis from one end, turn the clevis to lengthen or shorten the link, reconnect the clevis, and tighten the stop nut to the clevis (See Figure 8). **IMPORTANT:** Be sure the connecting pin of the clevis at the rockshaft end of the link is lined up with the center of the handle pivot bolt when the lever is in the neutral position. If the pin and pivot bolt do not have common centers, the link from the valve to the rockshaft must be adjusted to achieve common centers before the actuator lever link is adjusted.

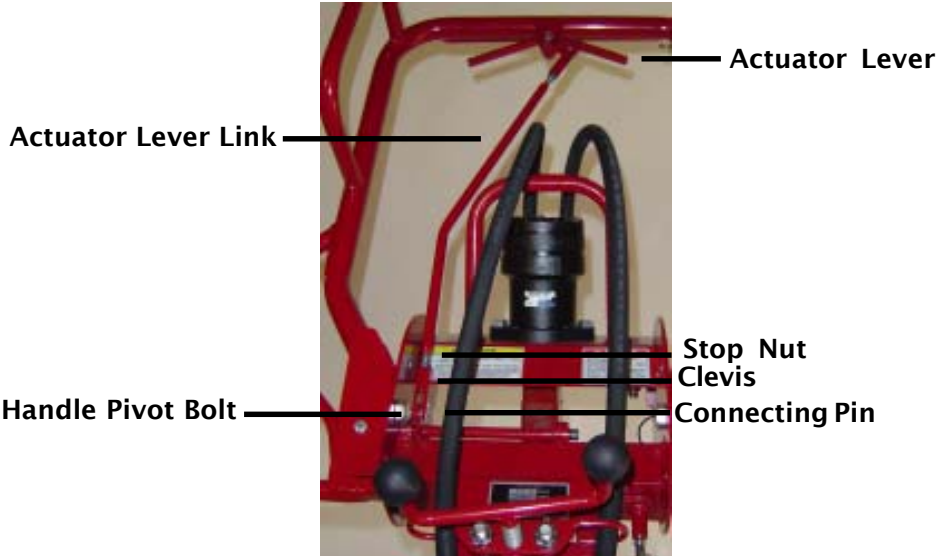

Figure 8



TOWING

⚠ DANGER: NEVER tow at a rate of speed greater than 25 mph. Adjust coupler to 2" ball only. Properly install safety chains.

Before connecting the tow bar, Be sure:

1. The engine is stopped.
2. There is no auger attached.
3. The drive head is in the locked position.
4. The handle side-to-side swivel is in the center, locked position.
5. The handle is pivoted and locked in the rearward position.
6. The machine is resting on the wheels and engine frame.

To connect the tow bar, slide the wide end of the tow bar underneath the axle. Then, hook the round bar on each side of the tow bar to the hooks on the rear side of the axle as shown in Figure 9. Then lift the tongue of the tow bar up into position and pin to the anchor point underneath the frame using the 3/4" diameter pin and hairpin cotter as shown in Figure 10.



Figure 9

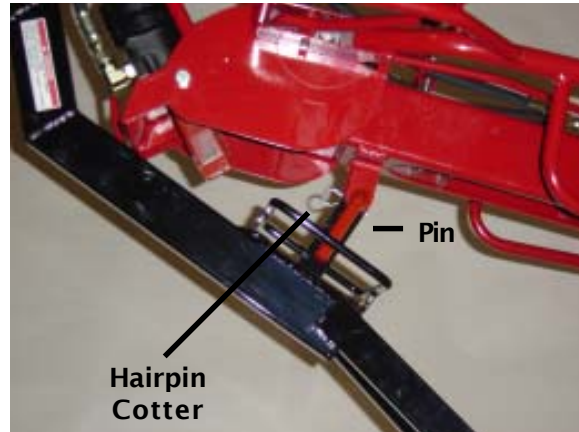

Figure 10

⚠ WARNING: ALWAYS tow with the slow moving vehicle (SMV) emblem properly installed.

⚠ WARNING: NEVER tow with the engine running

⚠ CAUTION: ALL nuts, fasteners, fittings, caps and threaded adjustment parts must be kept tightened. Be aware that improperly tightened components may become loose while towing. (See torque chart at the end of the manual).

⚠ CAUTION: Be sure to comply with all state and highway regulations when towing.

NOTE: To improve towing performance, it is recommended to inflate tires to a cold inflation pressure of 25 psi to 30 psi.



OPERATION

BEFORE STARTING THE ENGINE, Be sure that:



DANGER: NEVER run engine inside building or enclosed area. Exhaust gases contain carbon monoxide, an odorless and deadly poison.

- 1.) Engine is properly prepared to Manufacturer's specifications. Note: Engines with "Oil Guard" protection must be filled with oil to full mark on dipstick or to point of overflowing to allow the engine to start.
- 2.) Hydraulic Reservoir is filled to top of sight gauge.
- 3.) The tow bar is detached.
- 4.) Unlock the drive head and attach the auger to drive head adaptor. Make sure the snap button, in the auger, and hole provided in the adaptor are aligned and the button snaps securely into place.
- 5.) Make machine set-up adjustments for drilling the hole. Pivot the handle forward for regular drilling as shown in Figure 11A or pivot the handle rearward for up-close drilling as shown in Figure 11B. If necessary, swivel the handle to the side for drilling, vertical hole on unlevel terrain as shown in Figure 12.



Figure 11A
Regular Drilling



Figure 12



Figure 11B
Up-close Drilling

- 6.) Move the machine to the drilling site with the drive head in the locked position. Push the handle downward to a balanced position for moving the machine.
- 7.) The stop switch on the handle is in the "ON" position. (See Figure 13)
- 8.) The switch on the engine is in the "ON" position.

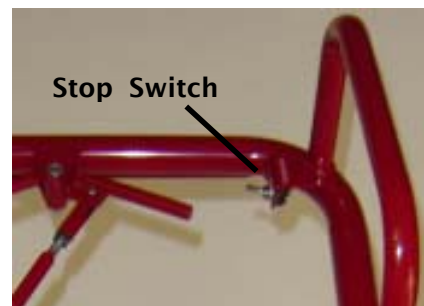

Figure 13



TO START THE ENGINE: Set the choke lever to the “ON” position and pull the starter rope. The engine should start after 2 or 3 pulls. Set the choke lever to the “OFF” position and allow the engine to warm-up for 2 or 3 minutes. Run engine at full throttle while drilling.



DANGER: NEVER drill holes where there is a possibility of underground power cables or other hazards. The exact location of underground services must be determined prior to drilling. Inadvertent severing of telephone, fiber optic or CATV transmission cable, or damage to sewer pipe is costly; RUPTURING OF GAS OR WATER LINES CAN CAUSE SERIOUS BODILY INJURY AND/OR DEATH. COMING INTO CONTACT WITH BURIED POWER LINES CAN CAUSE SERIOUS BODILY INJURY, SEVERE BURNS, AND/OR ELECTROCUTION. Call local utility companies or your local “One-Call” number at least 48 hours before digging and have underground utilities marked.



CAUTION: MAKE certain everyone is clear before operating the machine.



CAUTION: KEEP hands, feet and clothing away from moving parts while engine is running.

IMPORTANT: Note that the actuator lever must be depressed on opposite sides of the lever for the same auger rotation when the handle is pivoted between the forward and rearward positions. Figure 14A and 14B show the lever engagement for the auger rotation in the forward and rearward positions.

NOTE: For forward rotation, pivot the lever clockwise.
For reverse rotation, pivot the lever counter-clockwise.

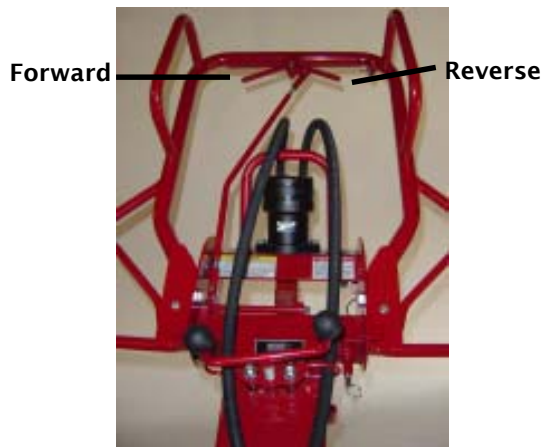

Figure 14A
Handle in forward position



Figure 14B
Handle in rearward position

There are two methods of operation for drilling with the towable hydraulic. Since the auger is driven about an arc around the axle, compensation must be made for the arc motion to ensure a vertical hole.

METHOD I: Starting with the auger in vertical alignment, the machine must be rolled away from the auger slightly as the auger is advanced downward. Conversely, the machine must be rolled toward the auger slightly as the auger is removed upward.

METHOD II: Starting with the auger in an angled alignment, the point of the auger should be positioned away from the axle, creating an angle from vertical. Without moving the position of the wheels or axle, advance the auger to the desired depth. At the desired depth, the top of the auger should be in vertical alignment with the bottom of the auger. This procedure will allow the removal of the auger from the hole without moving the position of the wheels or axle.

START THE AUGER TURNING. By pulling the actuator lever in completely. Always allow the auger to turn at full speed and let it cut its way into the soil.



IMPORTANT: When digging in soft soil, hold up slightly on auger. In hard pan, apply pressure, but not enough to stall the auger or slow it down significantly. The auger works best when it turns at full speed.

NOTE: Only use reverse to free the auger if it becomes lodged in the ground.

IF THE AUGER STALLS repeatedly or slows down significantly; stop the auger by releasing actuator lever, slightly lift up on auger, start auger by pulling actuator lever, and allow the auger to turn at full speed while slowly lowering it to bottom of hole.

 **CAUTION:** NEVER Remove auger from hole while auger is turning.

When the desired depth is reached, stop the auger by releasing the actuator lever. Then pull the auger completely out of the hole.

 **CAUTION:** Keep the back as vertical as possible by bending the legs, as required, during the operation and lifting procedure.

AUGER EXTENSIONS

 **CAUTION:** Stop the engine when making auger/extension connections.

If greater hole depths are required, extensions may be used with the auger. After the auger has reached its maximum depth, stop the engine and disconnect the drive adaptor from the auger which remains in the hole. Connect the extension to the auger as shown in figure 15. Connect the drive adaptor to the extension and continue to dig the hole.



FIGURE 15

When the desired depth is reached, stop the engine and disconnect the drive adaptor from the extension then remove the extension(s) and auger from the hole.

 **CAUTION:** When working with cutting blade, point and auger flighting; be careful not to be cut by sharp edges.

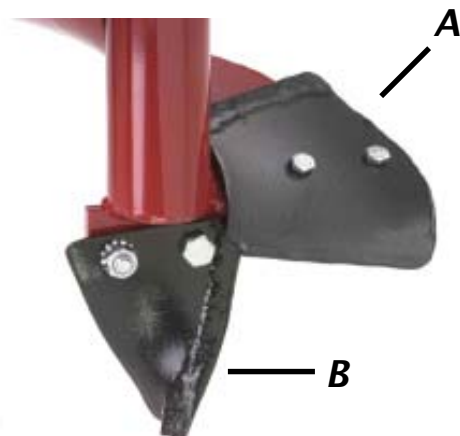

CUTTING BLADE

Check the cutting blade (Item A, Figure 16) on the auger frequently. If it becomes dull, it may be reversed to use the other cutting edge. If the outside of the blade wears even with the auger flighting, replace the blade or rebuild it with a hard surfacing rod. This is very important to reduce auger flighting wear and damage. The point (Item B, Figure 16) should be replaced when it loses its cutting shape.



**DECAL
LOCATION**



DRIVE HEAD



DRIVE HEAD



**SMV EMBLEM AND
REFLECTOR STRIPS**



TOW BAR



TROUBLESHOOTING

TROUBLE	CAUSE
Engine will not start	<ol style="list-style-type: none">1) Stop switch in off position on handle2) Engine stop switch is in "off" or "O" position3) Low fuel level in gas tank4) Low oil level in "Oil Guard" or "Oil Alert" equipped engines5) Spark plug fouled
Cannont connect or disconnect auger	<ol style="list-style-type: none">1) Foreign matter clogging auger adaptor2) Spring and button in top of auger is bent or broken
Auger turns too slowly and will not dig	<ol style="list-style-type: none">1) Too much downward pressure or binding on side of hole. Hold back if necessary to allow auger to turn at full speed.2) Linkage between control lever and valve is mis-adjusted. With engine off, ensure that neither lever touches handle bar when moved to full forward or reverse position. Re adjust linkage if necessary.
Auger turns but will not dig	<ol style="list-style-type: none">1) Foreign matter collected around point2) Point or blade is dull3) Wrong blade type for soil condition. Contact your dealer or factory for Little Beaver carbide blade
Auger with extension will not dig	<ol style="list-style-type: none">1) Auger or extension bent or running out of line2) Number of extensions exceeds capacity of machine
Hydraulic oil and/or hoses overheats	<ol style="list-style-type: none">1) It is normal for the hoses and reservoir to be warm to the touch. If it is very hot, consult your dealer or factory.
Auger will not stop turning when lever is released.	<ol style="list-style-type: none">1) Valve or linkage is binding. Do not use. Consult your dealer or factory.
Problems not listed in table	<ol style="list-style-type: none">1) Consult your dealer or factory.



TOWABLE PARTS MANUAL

NOTES:

ENGINE FRAME ASSEMBLY

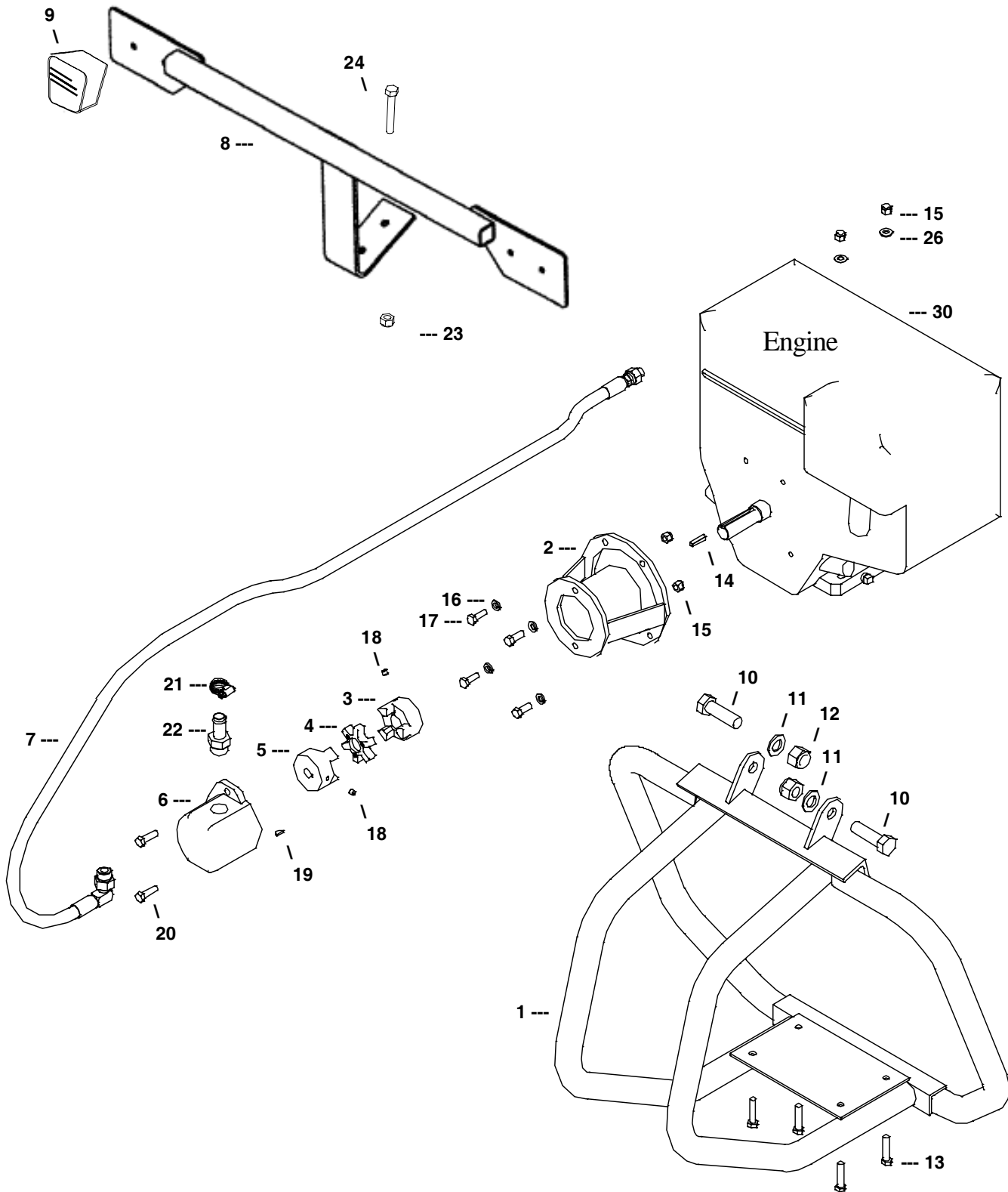

ENGINE FRAME ASSEMBLY

ITEM	PART #	DESCRIPTION	QTY
1	37039	Frame, Engine	1
2	37120	Bracket, Pump	1
3	30268	Flexible Coupling, 1" Bore	1
4	30269	Spider, Flexible Coupling	1
5	30267-58	Flexible Coupling, 5/8" Bore	1
6	30263-D2	Pump, Hydraulic	1
	30314-P#	Seal Kit, Prince Pump, SN 6657 and above	1
	30314-D#	Seal Kit, Dowty/Parker Pump	1
7	37159-P	Hose Assy. Pump to Valve, SN 6657 and above	1
	37159	Hose Assy. Pump to Valve	1
8	37164	Emblem, SMV ID	1
9	37163	Bracket, SMV Emblem	1
10	37124	Bolt, Hex 3/4 x 2-1/2	2
11	30164	Washer, 3/4 Flat, SAE	2
12	9096	Nut, 3/4 Nylon Lock	2
13	37179	Cap Screw, Socket Head, 3/8 x 1-3/4	4
14	4081	Key, Engine Shaft	1
15	30154	Nut, 3/8 Nylon Lock (pump mounting)	4
16	3012-3	Washer, 3/8 Lock	4
17	3012-2	Bolt, Hex, 3/8 x 1	4
18	30171	Set Screw, 5/16 x 5/16	2
19	30168	Key, Woodruff #505	1
20	9027-8	Bolt, Hex 3/8 x 1-1/4	2
21	30270-3	Clamp, Hose	2
22	37161	Fitting, 1-1/16 x 3/4 Bead	1
	37212	Fitting, 7/8 x 3/4 Bead, SN 6657 and above	1
23	30204	Nut, 1/4 Nylon Lock	4
24	30318	Nut, 5/16 Nylon Lock	2
25	9024	Bolt, Hex 1/4 x 7/8	2
26	3002-B	Washer, 3/8 Flat, Heavy	4
30	3001-11H	Engine, 11 HP Honda	1
31	9024-1	Bolt, Hex 5/16 x 1	2



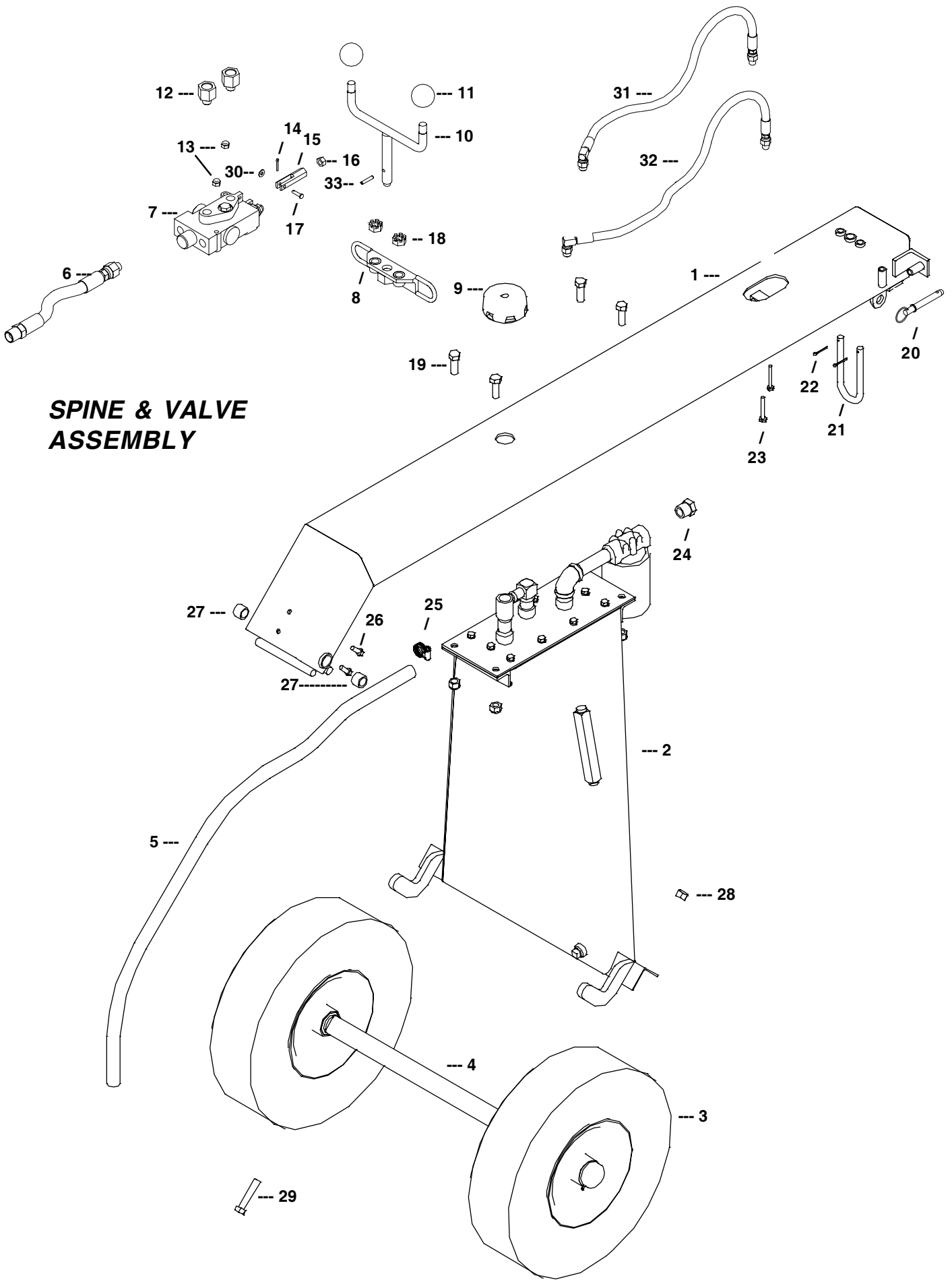

**SPINE & VALVE
ASSEMBLY**



SPINE & VALVE ASSEMBLY

ITEM	PART #	DESCRIPTION	QTY
1	37022	Spine Assembly	1
2		Hydraulic Tank (see page P-10 for breakdown)	1
3	37004	Wheel Assembly (see page P-11 for breakdown)	2
4	37000	Axle Assembly (includes Wheels	1
	37001	Axle ONLY	1
5	37162	Hose, Tank to Pump	1
6	37157	Hose, Valve to Tank	1
7	37141	Valve, 4-way with Relief	1
	30275-2	Seal Kit, Valve	
8	37082	Angle, Neck Lock	1
9	37165	Cap, Filler Breather	1
10	37085	Neck Lock Screw	1
11	37088	Knob, Handle	2
12	37155	Adaptor #6410-6-8	2
13	30204	Nut, Hex 1/4 w/Nylon Lock	2
14	37171	Pin, Clevis, 3/16 x 3/4	2
15	37138	Clevis, 5/16 NC	1
16	3002-D	Nut, Hex 5/16	1
17	30179	Cotter Pin, 3/32 x 5/8	1
18	37134	Nut, 1/2 Slotted	2
19	30408	Bolt, 1/2 x 1-1/2 Hex	4
20	37181	Pin, Ball Lock, 3/8	1
21	37133	U-Bolt, 1/2"	1
22	30163	Cotter Pin, 1/8 x 1	2
23	5076	Bolt, 1/4 x 2 Hex	2
24	30282	Bushing, 3/4 male x 1/2 female	1
25	30270 -3	Clamp, Hose	1
26	9024-1	Bolt, 5/16 x 1 Hex	2
27	37123	Bushing	2
28	30158	Nut, 1/2 Hex w/Nylon Lock	2
29	6533	Bolt, 1/2 x 2-1/2 Hex	2
30	4033-1	Washer, Flat #10	1
31	37197	Hose Assembly, Valve to Motor, Left Hand	1
32	37198	Hose Assembly, Valve to Motor, Right Hand	1
33	KT039	Roll Pin, 3/16 x 1	



HEAD, NECK AND MOTOR ASSEMBLIES

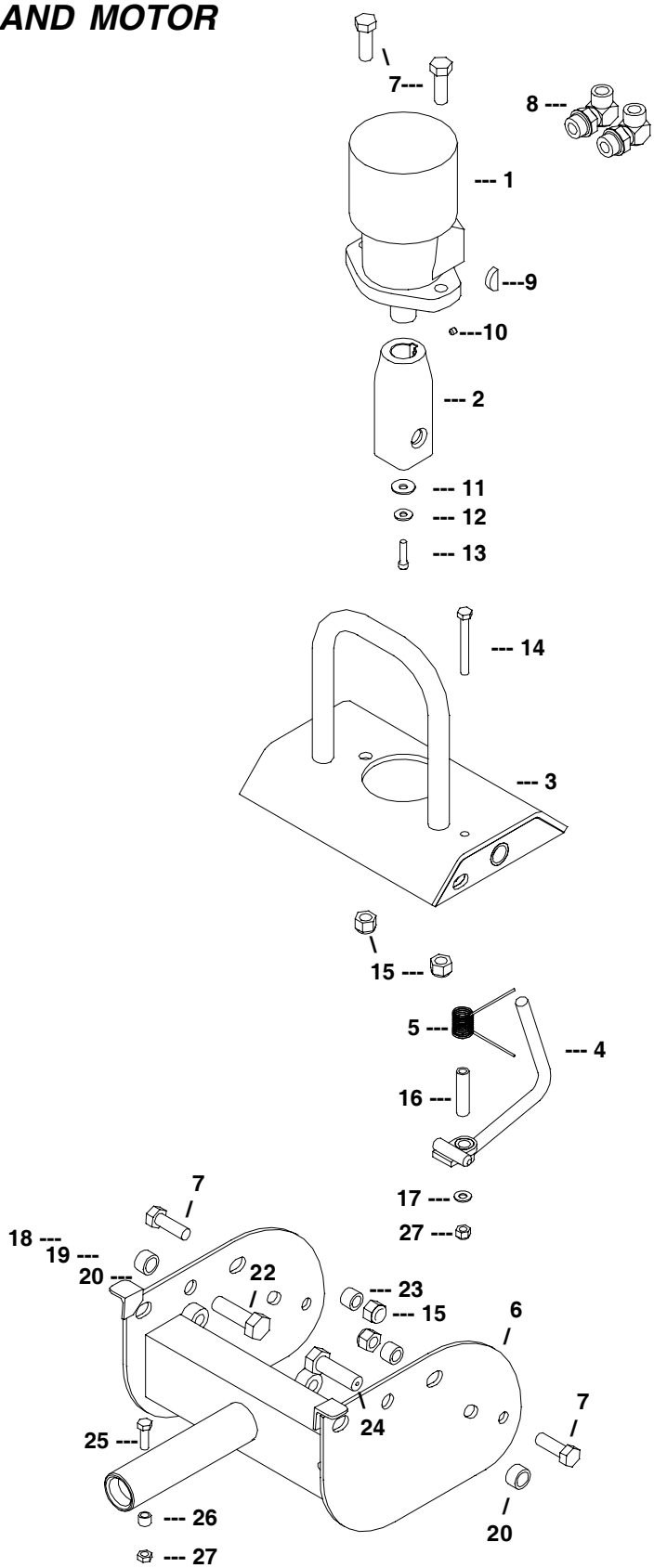

HEAD, NECK AND MOTOR ASSEMBLIES

ITEM	PART #	DESCRIPTION	QTY
1	30191-S2	Motor, 103-1028, 150RPM	1
	30191-5	Motor, 103-1029, 125RPM	1
	30162-D	Seal Kit, Motor (not pictured)	1
2	30272	Adaptor, (includes hardware)	1
3	37053	Head Weldment	1
4	37075	Lever, Head Lock	1
5	37145	Spring, Head Lock	1
6	37046	Neck Weldment	1
7	30408	Bolt, Hex 1/2 x 1-1/2	4
8	70304	Fitting, O-Ring to JIC, SN 6657 and above	2
	30296	Fitting, O-Ring	2
9	30182	Key, Woodruff #806	1
10	9021	Set Screw, 1/4 x 1/4	1
11	10520	Washer, Disc Spring	1
12	10304	Washer, 1/4 Flat	1
13	30010	Screw, 1/4 x 1 Socket Head Cap	1
14	37132	Bolt, 5/16 x 2-3/4 Hex	1
15	30158	Nut, 1/2 Hex w/Nylon Lock	4
16	37131	Bushing	1
17	10305	Washer, 5/16 Flat	1
18	36412	Nut, 5/16 Hex w/Nylon Lock	2
19	37172	Washer, 5/8 Flat SAE	2
20	37127	Bushing	2
22	37128	Bolt, 5/8 x 2 Hex	1
23	37126	Bushing	2
24	37130	Bolt, 5/8 x 2 Hex with hole	1
25	9024-1	Bolt, 5/16 x 1 Hex	1
26	37125	Bushing	1
27	37182	Nut, 5/16 Hex Top Lock	1



HANDLE AND ROCK SHAFT LINKAGE

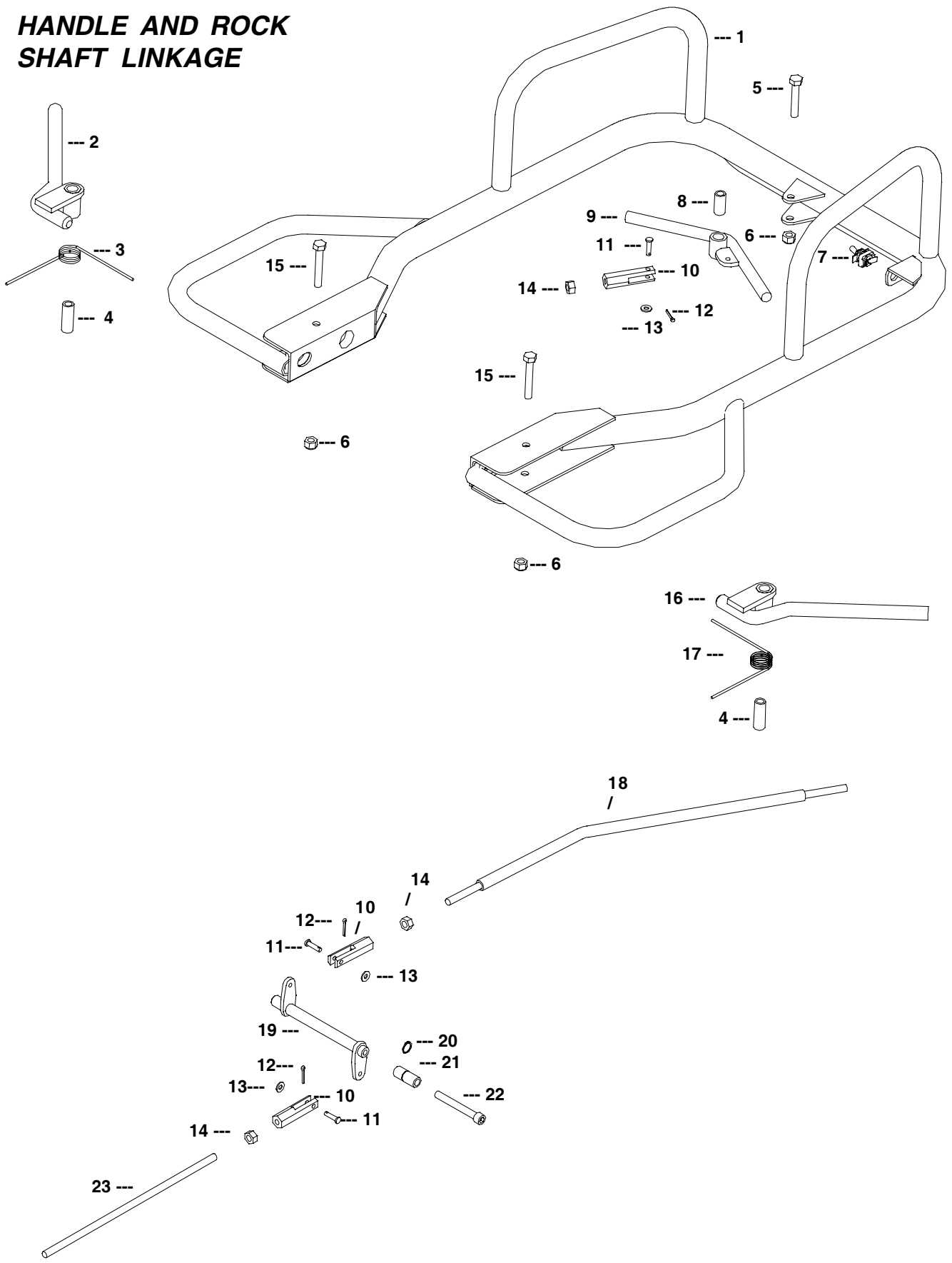

HANDLE AND ROCK SHAFT LINKAGE

ITEM	PART #	DESCRIPTION	QTY
1	37061	Handle Weldment	1
2	37101	Handle Lock, Left	1
3	37144	Spring, Handle Lock Left	1
4	37140	Bushing	2
5	3002-A	Bolt, Hex 5/16 x 1-3/4	1
6	30318	Nut, Hex 5/16 w/Nylon Lock	3
7	10470	Kill Switch Assembly	1
8	37137	Bushing	1
9	37093	Lever, Valve	1
10	37138	Clevis, 5/16 NC	3
11	37171	Pin, Clevis, 3/16 x 3/4	3
12	30179	Cotter Pin, 3/32 x 5/8	3
13	4033-1	Washer, Flat #10	3
14	3002-D	Nut, Hex, 5/16	3
15	3010-9	Bolt, Hex, 5/16 x 2	2
16	37100	Handle, Lock, Right	1
17	37143	Spring, Handle Lock Right	1
18	37097	Link, Lever	1
19	37089	Rockshaft	1
20	37135	Retaining Ring, External 13	1
21	37092	Bar, Rockshaft End	1
22	37136	Cap Screw, Socket Head 5/16 x 2	1
23	37146	Link, Valve	1



HYDRAULIC TANK ASSEMBLY

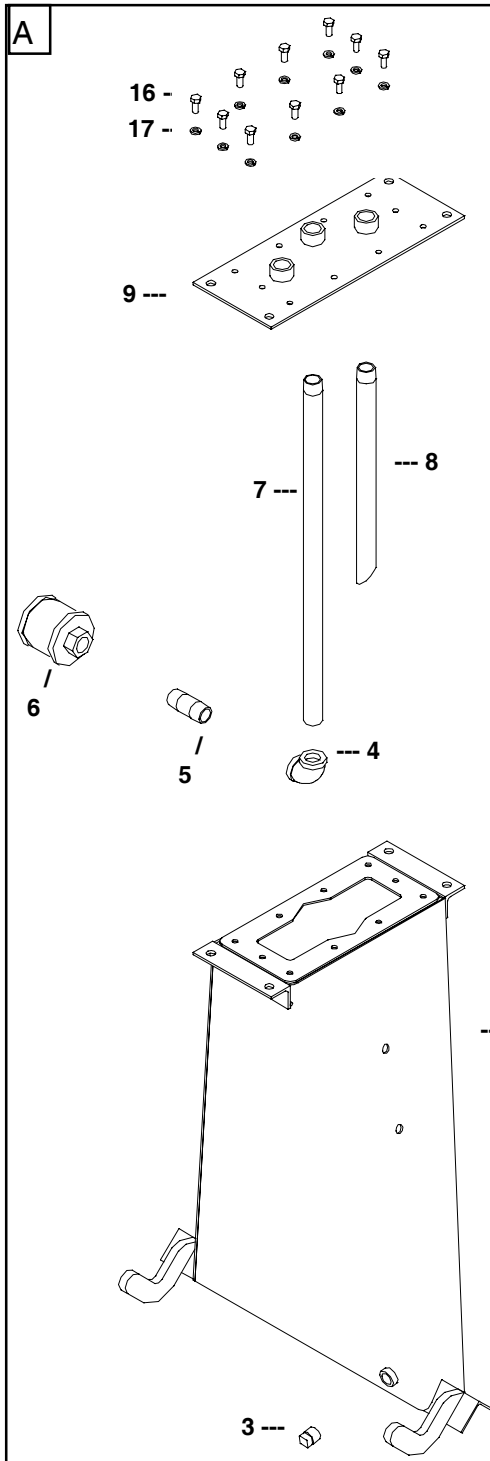
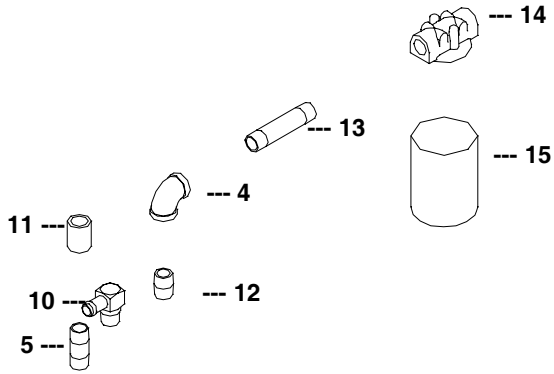

ITEM	PART #	DESCRIPTION	QTY
A	37005	Hydraulic Tank Assy Complete	1
1	37006	Hydraulic Tank Weldment	1
2	30262	Sight Gauge Assembly	1
3	30159	Plug, Magnetic, 1/2	1
4	30312	Elbow, 3/4 Standard	2
5	30310	Nipple, 3/4 x 2-1/2	2
6	30266	Strainer, Suction	1
7	37020	Pipe, Inlet	1
8	37019	Pipe, Return	1
9	37016	Lid, Hydraulic Tank	1
10	35286	Elbow, 90, 3/4 NPT	1
11	9-30023	Coupling, 3/4 NPT	1
12	35290	Nipple, Close, 3/4 NPT	1
13	37021	Pipe, Return Filter	1
14	30281	Filter Base	1
15	30280	Filter	1
16	3012-1T	Bolt, Hex 5/16 x 3/4	10
17	3002-C	Washer, Lock 5/16	10



HITCH AND WHEEL BREAKDOWN

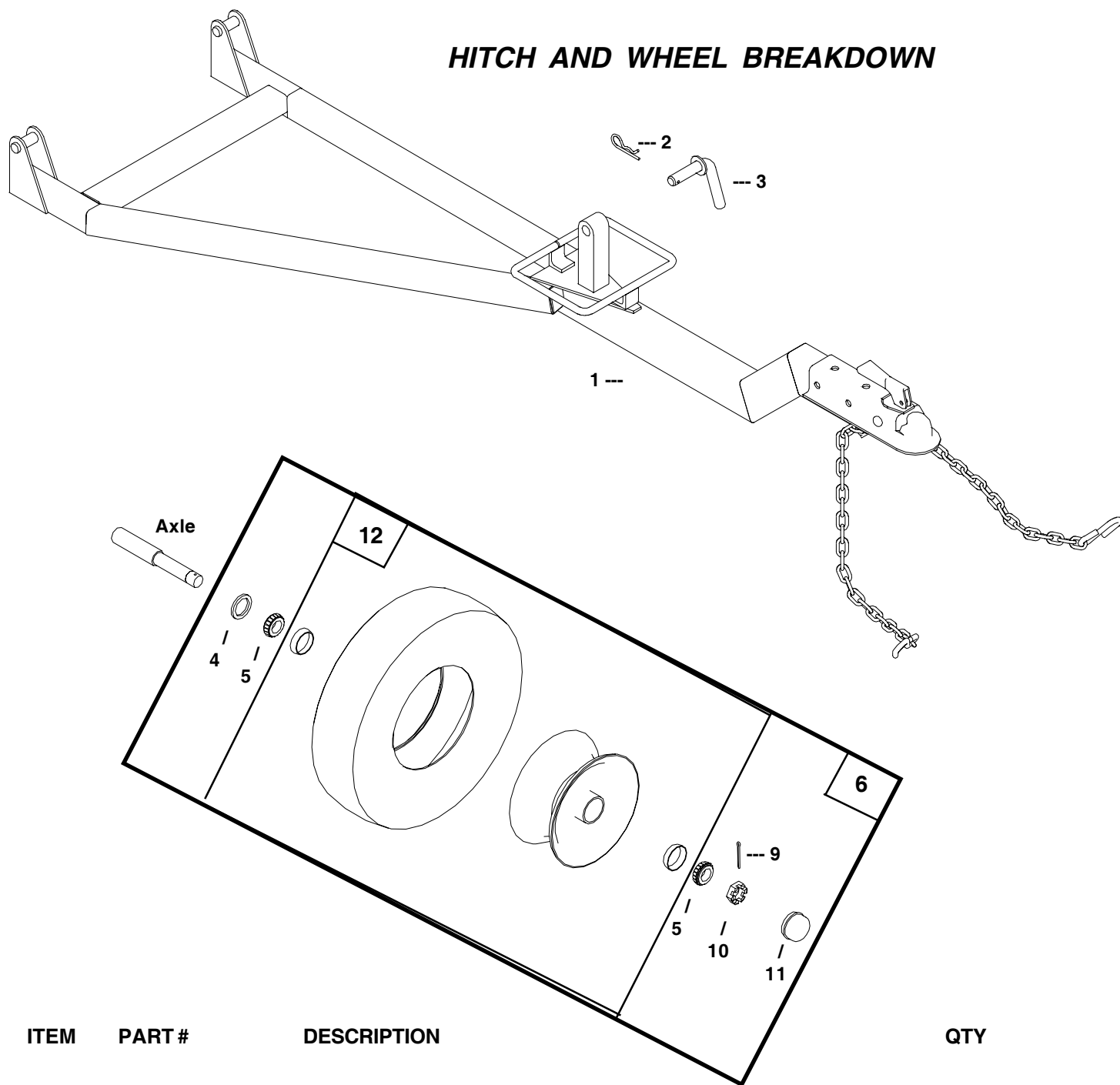







ITEM	PART #	DESCRIPTION	QTY
1	37105	Hitch	1
2	9059-1	Cotter, hairpin	1
3	36433	Pin	1
4	37004-3	Seal	1
5	37004-4	Bearing, Cone	2
6	37004	Wheel Assembly, Complete	2
9	37004-7	Cotter Pin	1
10	37004-6	Nut, Spindle, 1-14	1
11	37004-8	Cap, Grease	1
12	37004-P	Tire/Wheel only	1



NOTES:

IMPORTANT: All nuts, fasteners, and fittings must be kept tightened. Refer to torque chart for proper assembly torque.

TORQUE INFORMATION

 TYPE SIZE	HEX HEAD		SOCKET		
	 GRADE 5	 GRADE 8	 WRENCH SIZE inch	 	 WRENCH SIZE
No. 4	8 in lb	12 in lb	1/4"	12 in lb	3/32"
No. 6	16 in lb	23 in lb	5/16"	21 in lb	7/64"
No. 8	30 in lb	41 in lb	11/32"	42 in lb	9/64"
No.10	43 in lb	60 in lb	3/8"	60 in lb	5/32"
1/4"	8 ft lb	12 ft lb	7/16"	12 ft lb	3/16"
5/16"	17 ft lb	25 ft lb	1/2"	24 ft lb	1/4"
3/8"	30 ft lb	45 ft lb	9/16"	43 ft lb	5/16"
7/16"	50 ft lb	70 ft lb	5/8"	69 ft lb	3/8"
1/2"	75 ft lb	110 ft lb	3/4"	105 ft lb	3/8"
9/16"	110 ft lb	150 ft lb	13/16"	158 ft lb	-----
5/8"	150 ft lb	220 ft lb	15/16"	195 ft lb	1/2"
3/4"	260 ft lb	380 ft lb	1-1/8"	353 ft lb	5/8"

HYDRAULIC FITTINGS

SIZE	TORQUE	SIZE	TORQUE
1/4 NPT	25 ft.lb.	7/16-20 SAE O-Ring	12 ft.lb.
3/8 NPT	50 ft.lb.	9/16-18 SAE O-Ring	20 ft.lb.
1/2 NPT	75 ft.lb.	3/4-16 SAE O-Ring	35 ft.lb.
3/4 NPT	110 ft.lb.	7/8-14 SAE O-Ring	50 ft.lb.
		1-1/16-12 SAE O-Ring	70 ft.lb.



**THINK
SAFETY
FIRST!**

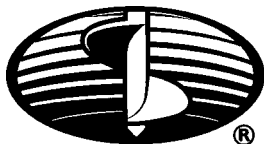

LITTLE BEAVER, INC.

P.O. BOX 840 • LIVINGSTON, TEXAS 77351

® PH# 936/327-3121 • FAX# 936/327-4025