

# SensingEdge

## Applications

- **Slide Gates**
- **Cantilever Gates**
- **Vertical Lift Gates**
- **Vertical Pivot Gates**

This pressure sensitive electric Sensing Edge can be adapted to suit a wide variety of gate applications. When touch activated, the MG123 sends an immediate electrical signal to controls to stop and/or reverse operations. The MG123 Sensing Edge has been designed to fit wide variety of gate installations and is custom manufactured to required length.



## OPTIONS

- Configurations:
  - 2-Wire 10K Resistive Monitored
  - 2-Wire Non-Monitored
- Soft ends
- Mounting channels

## TECHNICAL SPECIFICATIONS

Color:	Black
Length:	Per specification to +/- 1/4"
Lead Wire:	SJTO, 18 gauge, 2' length or 22 gauge universal
Sensitivity:	Nominal 6-11 lbf
Electrical Maximum:	24V AC/DC, 1/2 amp
Mechanical Diagram:	See drawings on page 2
Contact Element:	Alumaglas®
Materials:	Extruded flexible PVC
Mounting Channel:	Rigid PVC or aluminum
Temperature Range:	-30° F to +155° F
Wire Outlet Location:	Universal, right, left, or end

## FUNCTIONAL BENEFITS

- Touch sensitive signalling
- Easy to install
- Mounts vertically or horizontally
- ANSI/UL 325 Recognized Component

 Designed for gates



**Model: MG123**

# **SensingEdge**

## **INSTALLATION**

Slide MG123 Sensing Edge into proper channel. To attach mounting channel, place in desired location. Drill 1/8" holes through channel and into mounting surface. Secure with screws.

*Note:* For safe operation, use a maximum 24 volt, 1/2 amp AC or DC power. For detailed installation and wiring instructions, contact Miller Edge.

## **CARE & MAINTENANCE**

Minimal care is required for the MG123 since it is manufactured with only the most durable materials and the highest quality control standards. However, Sensing Edges must be examined regularly for cuts or punctures, which could damage internal components. Check wiring to be sure connections are secure. When properly maintained, the MG123 offers years of trouble-free operations.

## **WARRANTY**

Miller Edge, Inc. will replace within one year of shipment from factory, any Sensing Edge subject to normal use, which is found to have defective materials or workmanship, as determined solely by our factory representative. Replacements will be shipped to you freight collect. This warranty is void where evidence of misuse or abuse is present.

## **MECHANICAL DIAGRAMS**

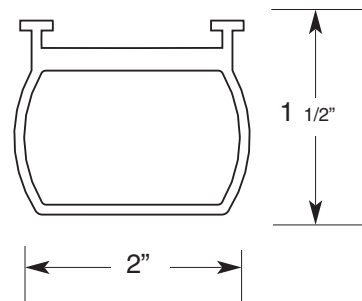

## **WIRE OUTLET LOCATIONS**

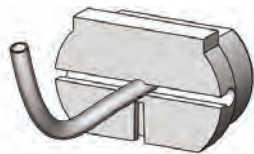

**Universal End**

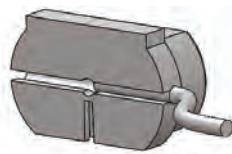

**Universal Side**

## **MOUNTING CHANNELS**

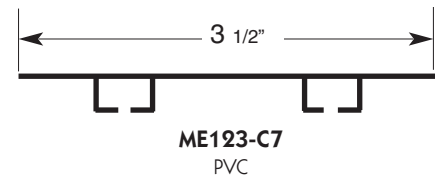
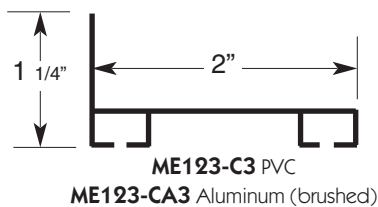
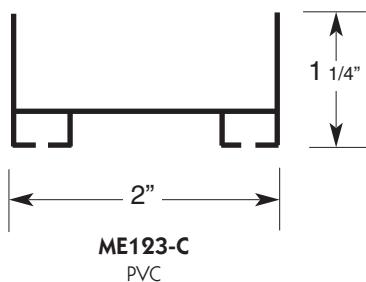

Contact Miller Edge to ensure compatibility with your operating controls.  
U.S. Patent 9,091,108 Other patents apply.

MG123\_Spec\_20180801

P.O. Box 159 • West Grove, PA 19390 • 610-869-4422 • Fax: 610-869-4423 • 800-220-3343  
6809 South Harl Avenue, Suite A • Tempe, AZ 85283 • 480-755-3565 • Fax: 480-755-3558 • 800-887-3343  
[www.milleredge.com](http://www.milleredge.com)