

PART #	U-BOLT TYPE
NW-TRLLBKT-R-HD	ROUND
NW-TRLLBKT-S-HD	SQUARE

REVISIONS		DATE	APPD
ECR/DCR	REV.	DESCRIPTION	
-	-	INITIAL RELEASE	1-19-16

NW-TRLLBKT-R-HD

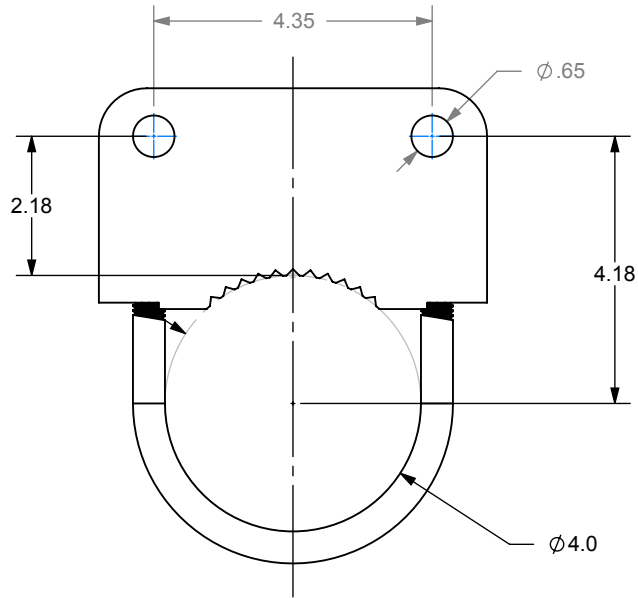

NW-TRLLBKT-S-HD

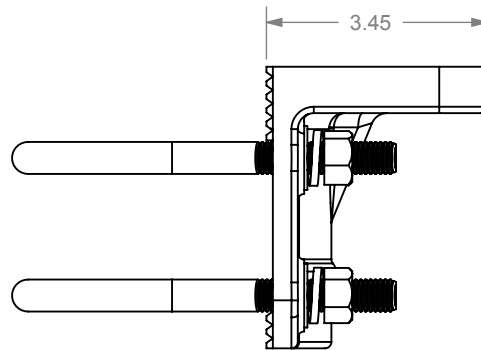
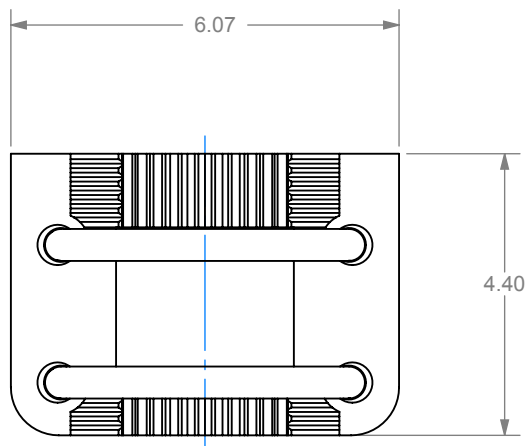
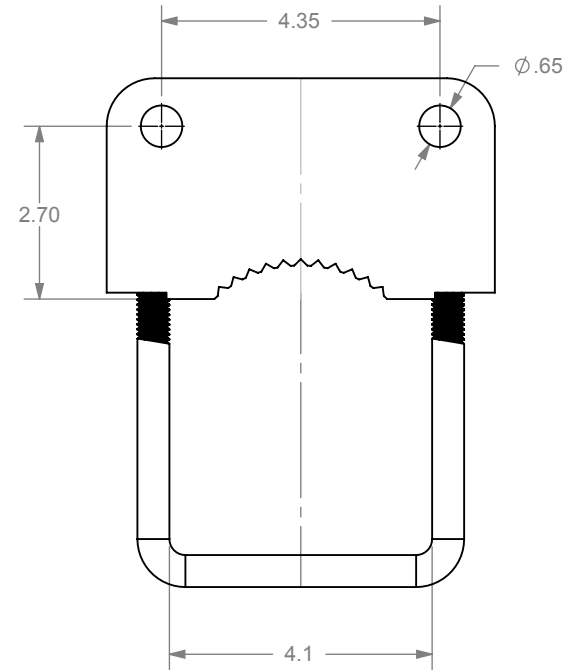

DIMENSIONS ARE IN INCHES
 TOLERANCES:
 FRACTIONAL $\pm 1/16$ "
 ANGULAR: MACH $\pm 1^\circ$ BEND $\pm 1^\circ$
 TWO PLACE DECIMAL ± 0.01
 THREE PLACE DECIMAL ± 0.005

PROPRIETARY AND CONFIDENTIAL
 THE INFORMATION CONTAINED IN THIS
 DRAWING IS THE SOLE PROPERTY OF
 NATIONWIDE INDUSTRIES. ANY
 REPRODUCTION IN PART OR AS A WHOLE
 WITHOUT THE WRITTEN PERMISSION OF
 NATIONWIDE INDUSTRIES IS PROHIBITED.

**NATIONWIDE
 INDUSTRIES**

**CANTILEVER TROLLEY
 BRACKET 4"
 R/S POST**

SIZE	DWG NO.	REV.
A	CS--NW-TRLLBKT-HD	-
SCALE: 1:3	WEIGHT:	SHEET 1 OF 1