

PACKAGING INSTRUCTIONS:

EACH SET CONTAIN:

1. INDIVIDUALLY POLYBAGGED (2) HINGE ASSEMBLIES, (2) BASE "A" ASSEMBLY, AND (2) BASE "B" ASSEMBLY.
2. (1) 3/32 HEX KEY, (2) TOP CAP, (2) BOTTOM CAP, (12) 1/4" FLAT WASHER AND (12) 1/4-20 ACORN NUT POLYBAGGED.
3. (32) #8 x 3/4" LG. PAN HEAD PHILLIPS SCREWS, S/S, POLYBAGGED.

ECR/DCR REV.		REVISIONS DESCRIPTION	DATE	APPD
-	-	-	-	-

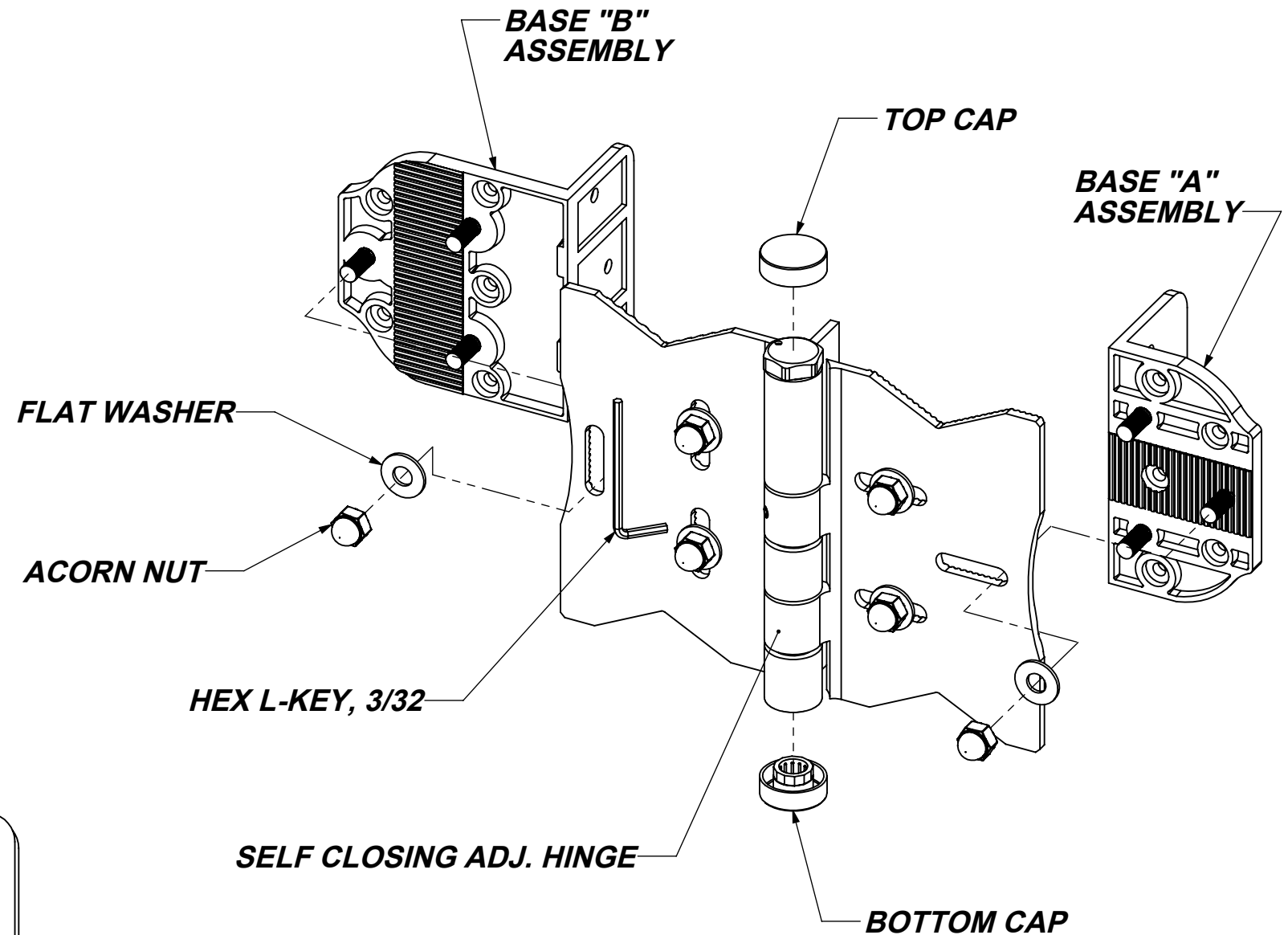
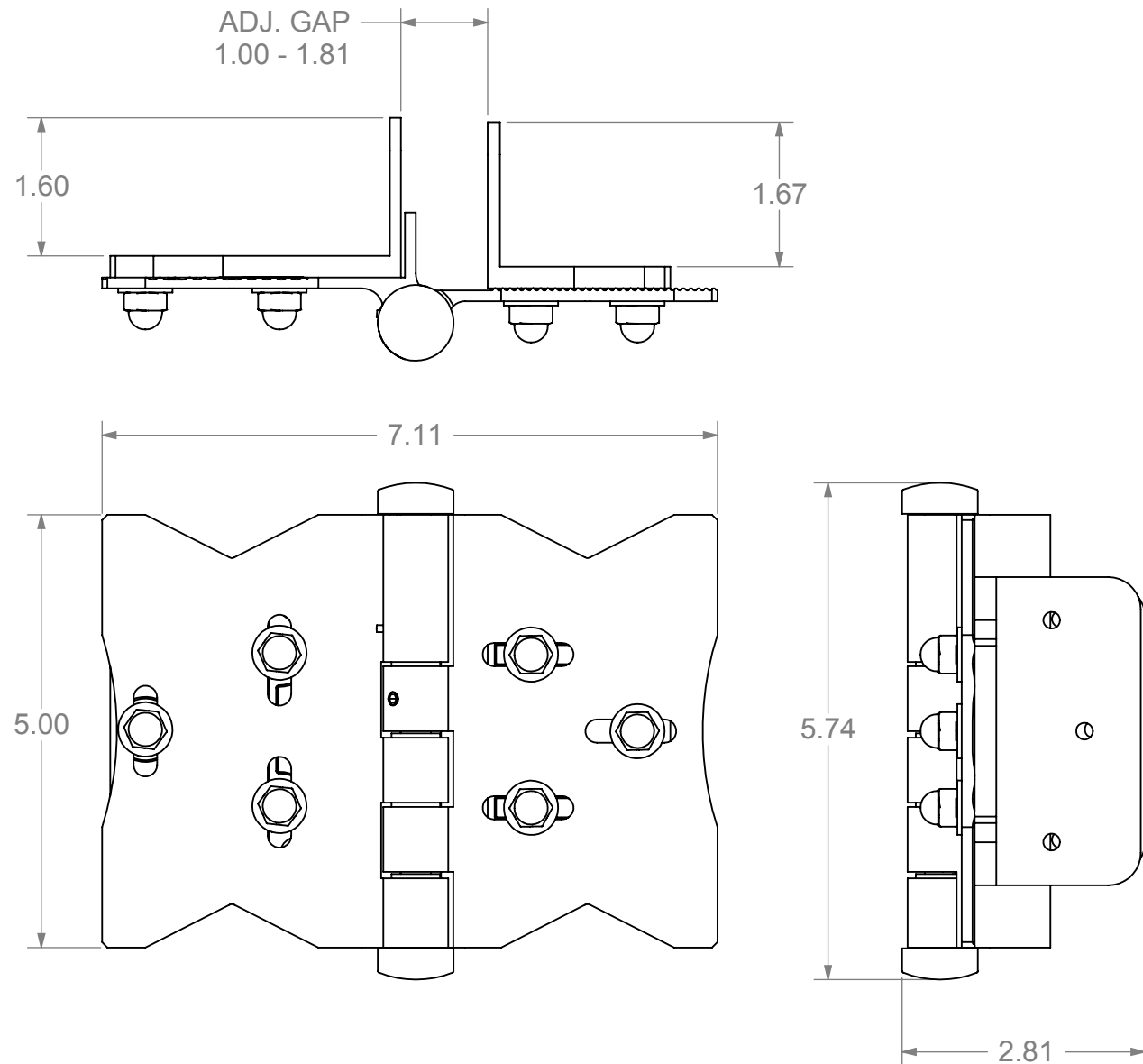

HINGE CAN BE ADJUSTABLE VERTICALLY AND HORIZONTALLY 13/16" MAX.

DRAFT COPY

PROPRIETARY AND CONFIDENTIAL

THE INFORMATION CONTAINED IN THIS DRAWING IS THE SOLE PROPERTY OF NATIONWIDE INDUSTRIES. ANY REPRODUCTION IN PART OR AS A WHOLE WITHOUT THE WRITTEN PERMISSION OF NATIONWIDE INDUSTRIES IS PROHIBITED.

DO NOT SCALE DRAWING



SELF CLOSING ADJ. HINGE

SIZE B	DWG. NO. CS--NW093V	REV. -
SCALE:1:2	WEIGHT: 1.75 LB	SHEET 1 OF 1