

PART #	COLOR	L*	a*	b*	G*
NW6197-SBL	MILL	-	-	-	-
NW6197-BK	BLACK	24	0	0	35
NW6197-WH	WHITE	94.5	-1.4	1.5	80
NW6197-BZ	BRONZE	34	.53	2.1	15
NW6197-BZ2	BRONZE2	36.4	.74	3.53	58

ECR/DCR		REV.	REVISIONS		DATE	APPD
			DESCRIPTION			
-	-		INITIAL RELEASE		2/7/17	-

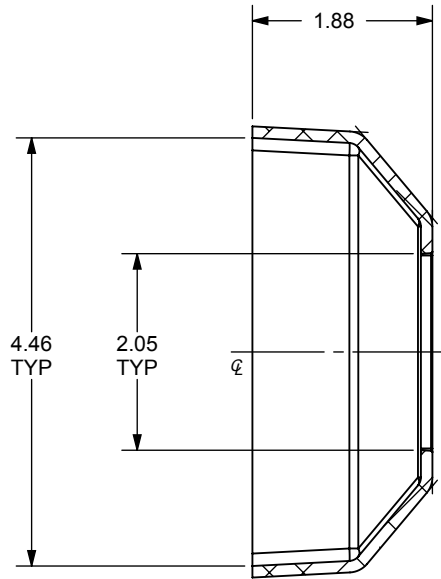

SECTION A-A

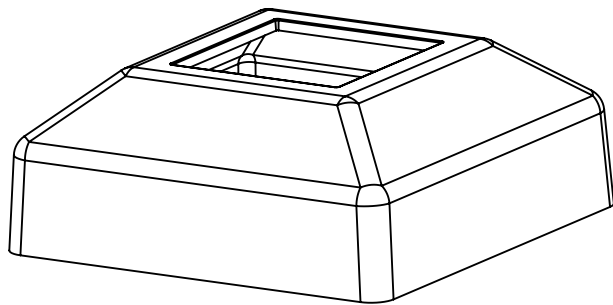
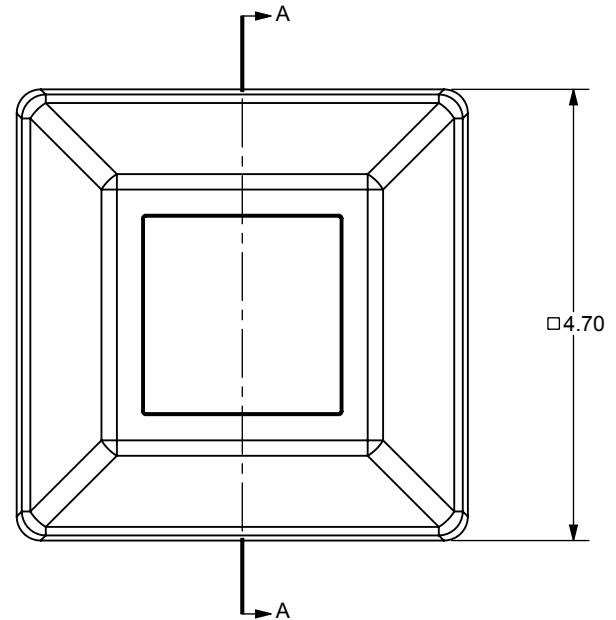

**PROPRIETARY AND CONFIDENTIAL**  
 THE INFORMATION CONTAINED IN THIS DRAWING IS THE SOLE PROPERTY OF NATIONWIDE INDUSTRIES. ANY REPRODUCTION IN PART OR AS A WHOLE WITHOUT THE WRITTEN PERMISSION OF NATIONWIDE INDUSTRIES IS PROHIBITED.

DIMENSIONS ARE IN INCHES TOLERANCES: FRACTIONAL: ±1/16" ANGULAR: MACH ±1° BEND ±1° TWO PLACE DECIMAL ±0.01 THREE PLACE DECIMAL ±0.005		NAME <b>EET</b>	DATE <b>2/7/17</b>	 <b>NATIONWIDE INDUSTRIES</b>  <b>COVERPLATE FOR 2" FLOOR MOUNT</b>
MATERIAL <b>A360 ALUMINUM</b>		DRAWN		
FINISH <b>POWDERCOAT / MILL</b>		CHECKED		
DO NOT SCALE DRAWING		ENG APPR.		
		MFG APPR.		<b>CS--NW6197</b> SIZE: <b>A</b> DWG. NO. <b>CS--NW6197</b> REV. <b>-</b> SCALE: 1:2 WEIGHT: SHEET 1 OF 1
		Q.A.		
		COMMENTS:		