

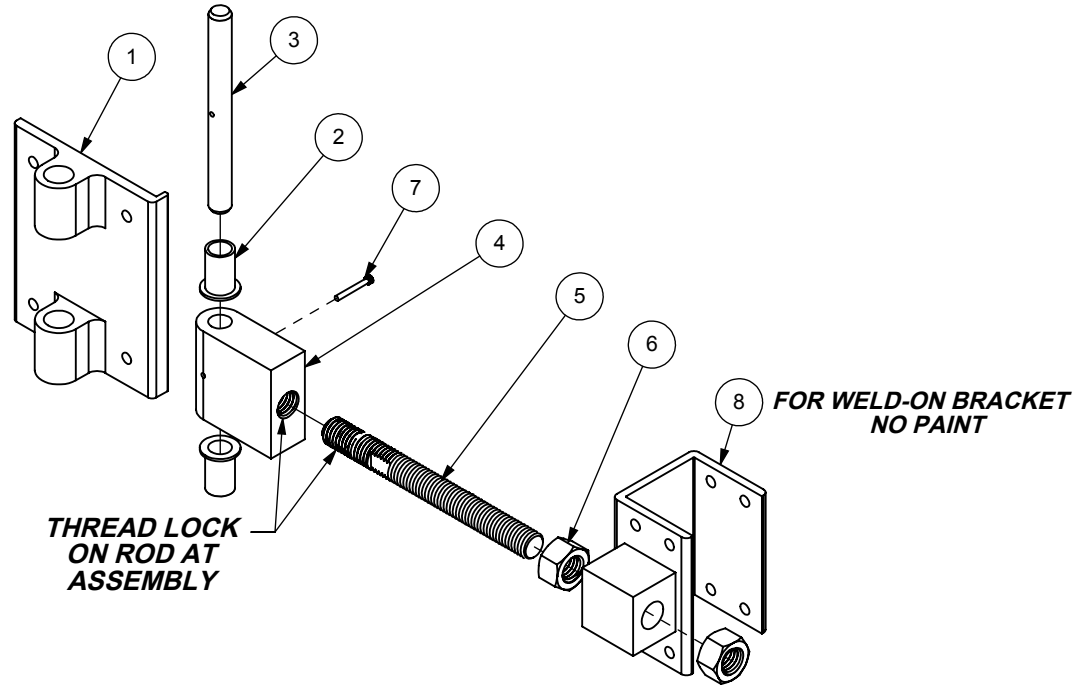

ITEM #	DESCRIPTION	QTY.
1	POST LEAF	1
2	BUSHING	2
3	PIVOT PIN	1
4	PUCK	1
5	THREADED ROD	1
6	ADJUSTMENT NUT	2
7	RETENTION PIN	1
8	GATE LEAF ASSEMBLY	1

REVISIONS				
ECR/DCR	REV.	DESCRIPTION	DATE	APPD
-	-	INITIAL RELEASE	05/02/13	CGS

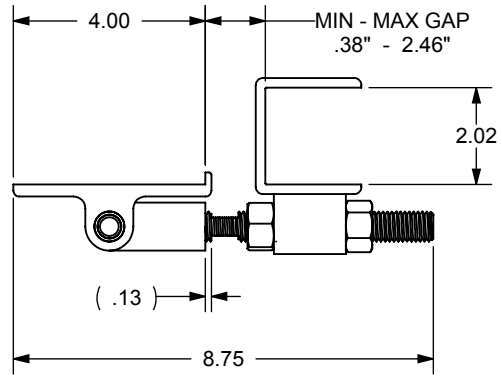
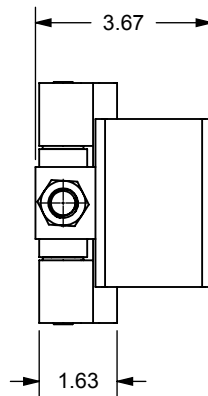
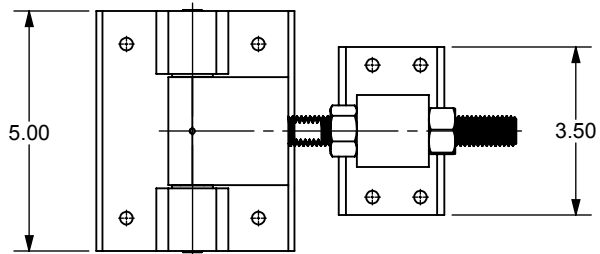

FOR REFERENCE PURPOSES ONLY
BOLT-ON VERSION SHOWN



DIMENSIONS ARE IN INCHES TOLERANCES: FRACTIONAL $\pm 1/16"$ ANGULAR: MACH $\pm 1^\circ$ BEND $\pm 1^\circ$ TWO PLACE DECIMAL ± 0.01 THREE PLACE DECIMAL ± 0.005		 NATIONWIDE INDUSTRIES
PROPRIETARY AND CONFIDENTIAL THE INFORMATION CONTAINED IN THIS DRAWING IS THE SOLE PROPERTY OF NATIONWIDE INDUSTRIES. ANY REPRODUCTION IN PART OR AS A WHOLE WITHOUT THE WRITTEN PERMISSION OF NATIONWIDE INDUSTRIES IS PROHIBITED.		
HEAVY DUTY ESTATE GATE HINGE		CS--NW6242
SIZE: A	DWG. NO.	
SCALE: 1:4	WEIGHT:	SHEET 1 OF 1