

Nice Swing Gate Actuator

Model 1551

Vehicular Swing Gate Actuator

1050 Control Board

816 actuator installation instructions and programming and controls for 1050 Control Board



CBOX with 1050 control board



816 Actuator



Programming for 1050 Control Board - page 21

These operators use the 1050 control board: 1551 LA, TITAN12L1 and 3501
See separate installation and reference manuals for TITAN12L/12L1 (912L-1)
actuator and 3501 (ABOX35) arm

TABLE OF CONTENTS

1 - OVERVIEW	4	25 - GENERAL LAYOUT AND SAFETY ACCESS	28
2 - General Safety Information	6	26 - ACCESSORIES AND SENSORS	29
3 - Use of Vehicle Detectors	9	27 - IRB-BET WIRING DIAGRAM	30
4 - Gate Construction and Safety	9	28 - GEM-103 WIRING DIAGRAM	30
5 - Maintenance of Gate Systems	11	29 - WEL-200 WIRING DIAGRAM	31
6 - Entrapment Protection	12	30 - BOARD NOMENCLATURE	32
7 - Compatible External Sensors	13	31 - PROGRAMMING BUTTONS	33
8 - PARTS IDENTIFICATION	14	31.1 - Force	33
9 - PULL TO OPEN INSTALLATION	15	31.2 - Speed	33
10 - PUSH TO OPEN INSTALLATION	16	31.3 - Acceleration	33
11 - ACTUATOR MOUNTING	16	31.4 - Delay	33
12 - CONTROL BOX MOUNTING	17	31.5 - Function	33
13 - 1050 CIRCUIT BOARD LAYOUT	17	31.6 - Display	34
14 - INCOMING POWER WIRING	18	32 - EMERGENCY VEHICLE ACCESS	35
15 - ACTUATOR WIRING	19	33 - GLOSSARY	35
16 - GATE BRACKET MOUNTING	20	34 - MAINTENANCE SCHEDULE	36
17 - LIMIT SWITCH ADJUSTMENT	20	35 - TROUBLESHOOTING	36-37
18 - SETTING LIMIT SWITCHES	21	36 - OPERATOR DIMENSIONS	38
19 - LEARNING MODE	22	36.1 - Control box dimensions	38
20 - ACCESSORY INPUTS AND OUTPUTS	23	36.2 - Actuator dimensions	39
20.1 - Outputs	23	37 - EXPLODED VIEW	40
20.2 - Inputs	23	37.1 - Control box	40
20.3 - Communication buses	24	37.2 - Actuator - Front	41
20.4 - Programming the plug-in receiver and remote controls	24	37.3 - Actuator - Back	42
21 - 120VAC POWER WIRING	25	38 - WARRANTY	43
22 - SOLAR PANEL CHART	25	39 - INSTALLATION CHECKLIST	44
23 - EXAMPLE WIRING CONNECTIONS	26	40 - Appendix - French Translations	45-48
23.1 - Fire dept. connection	26		
23.2 - Magnetic lock connection	26		
23.3 - Guard station	26		
23.4 - Exit and edge inputs wiring diagram	26		
23.5 - Radio receiver connection (third party)	27		
23.6 - Optional power output	27		
24 - INSPECTION AND OPERATION	27		

1. Overview

Congratulations on selecting a Nice gate operator for automating your gate system. With proper selection, system design, installation and maintenance this operator should provide years of reliable operation.

This manual covers the following Nice operator models: 1551 (programming for Titan12L1 and 3501).

1.1 1050 Control Board

The 1050 main control board is housed in a protective plastic enclosure that includes a 2-line LCD, with 5 dedicated buttons and 3 buttons for navigation of the setup, programming, and information menus, as well as 3 buttons for open, close, and stop. Connectors for power, inputs, and output peripherals are arranged around the edges of the board and clearly labeled. A plug-in connector is provided for direct installation of a Nice-brand receiver which can be controlled by up to 1000 transmitters. A recessed RJ-11 jack offers a connection to an optional O-View programmer and optional Bluetooth module that can be programmed via PC. Connectors for other Nice-brand plug in accessories include 2-wire Bluebus, self-monitored photocells for entrapment protection. Dry contact inputs are provided for loop, probe, and photoelectric detectors, as well as guard station and fire department control of gate opening and closing. Voltage outputs (+12VDC and +24VDC) are also made available to power safety and entrapment-prevention devices, and a magnetic lock if required. On board charge control circuitry delivers reliable power to a backup battery (if installed) and the unit is equipped with input for a solar panel for self-powered installations.

The 1050 main control board accepts DC input voltage ranging from 10VDC to 32VDC. A 2-line LCD with dedicated buttons allows installer to quickly program the 1050 when changes to its factory-default settings need to be made. A real time clock/calendar enables programming for scheduled weekly or daily events like opening, closing, or locking the gate. Gate opening and closing speed, acceleration, soft-start settings,

and reversing speed may be set to factory default settings, or individually programmed per customized gate installation requirements. Built-in current sensing enables inherent gate force monitoring and limiting for safety and an on board alarm indicates when two sequential obstructions have been sensed in either direction. The "Learn" function helps gate installer configure Nice 1050 control board semi-automatically for optimum settings of gate opening and closing speeds, with simple programmable adjustments to force and speed settings that may be made with the programming button on the control panel.

1.2 1050 Control Board Features

- Inputs for solar panel, batteries, and Main DC Power.
- Low power consumption in stand-by mode.
- Built-in regulator to keep battery charged (either through solar or main DC power).
- Socket for plug-in Nice receiver.
- Board compatible with Nice Opera System (facilitates programming and diagnostic's away from the site of installation). Requires optional O-View and OVBT (Bluetooth) module.
- Easy programming with LCD display and dedicated buttons.
- Digital programming for auto-close, force, speed, opening delay.
- On board buttons for operating the gate (Open, Close, Stop).
- Built-in voltmeter to check input voltage, battery voltage, solar panel voltage, motors' current.
- Temperature sensor to optimize charging battery and system performance.
- Programmable service alarm.
- 2 Programmable timers (from 1 sec to 9 hours).
- Inputs for guard station, additional third party receivers, loop detectors, FIRE and UL/Edge signals.
- 2 programmable inputs (open, close, step, mid-position, hold to open, hold to close, activating timer).
- Surge suppression on every peripheral input (digital and analog).
- Ports for self-powered Nice plug-in peripherals. (BlueBus).

1.3 What is Included

P/N	Name	Note
CBOX1050	Control Box	
#816-1	816 Actuator with 8' harness	
#816-2	816 Actuator with 42' harness	Add for Dual Gate Applications
#1116	Pivot Arm	Included in 816-1/816-2
#10025215	Gate Attach Bracket	Included in 816-1/816-2
#1125	Bolt Kit	Included in 816-1/816-2
ABF/A	Directional antenna 433 kHz kit	Included in CBOX
OXI/A	Nice Radio Receiver	
EPMB/A	BlueBus Photo Eye	

1.4 Product Specifications

Model	1551
Duty Cycle	Varies based on Charger Type
Drive	Electromechanical
Gate Length Max.	16 ft (5 m) leaf
Gate Weight Max	600 lb (272 kg)
Open/Close Time (to 90°)	14 - 16s (adjustable)
Temperature Rating	-4° to 122° F (-20° to 50° C)
Operating Voltage	12VDC
Input Voltage	10 - 32VDC
Idle Current	110 mA (awake) 10 mA (in Standby)
Accessory Power	12VDC and 24VDC 300 mA each
Actuator Dimensions	816: 42 retracted - 66 extended (107cm - 167.6cm)
User Controls	1050 board
Relays	2 programmable relays
Enclosure	CBOX: Type 3R, 18w x 18h x 8d inch (46w x 46h x 20.3d cm)
Listed to UL325	Usage Class I, II, III, IV

1.5 The installation of this product is not a “do-it-yourself” project. A qualified gate operator installation company should be contacted to install the gate operator to ensure a safe and reliable installation. Since many aspects of gate system installation are under the control of the installer, it is the responsibility of the property owner to ensure the installer is qualified to carry out the installation in a safe and professional manner.

1.6 Consult local government agencies for up-to-date rules and regulations as certain municipalities have established licensing, codes or regulations that regulate automated gate system design and installation.

2. General Safety Information

A gate operator is only a component in a gate system. The other parts of the gate system can include the gate, the external entrapment sensors, access controls, and vehicle detectors. To have a gate system that provides safety, security, and reliable operation it is essential these components operate together as a system. It is the responsibility of the system designer and/or installer to ensure any safety or operational issues have been addressed.

IMPORTANT SAFETY INSTRUCTIONS



WARNING

To reduce the risk of injury or death.

1. READ AND FOLLOW ALL INSTRUCTIONS.
2. Never let children operate or play with gate controls. Keep the remote control away from children.
3. Always keep people and objects away from the gate. **NO ONE SHOULD CROSS THE PATH OF THE MOVING GATE.**
4. Test the gate operator monthly. The gate **MUST** reverse on contact with a rigid object or stop when an object activates the non-contact sensors. After adjusting the force or the limit of travel, retest the gate operator. Failure to adjust and retest the gate operator properly can increase the risk of injury or death.
5. Use the emergency release only when the gate is not moving.
6. **KEEP GATES PROPERLY MAINTAINED.** Read the user's manual. Have a qualified service person make repairs to gate hardware.
7. The entrance is for vehicles only. Pedestrians must use separate entrance.
8. **SAVE THESE INSTRUCTIONS.**

2.1 UL325 Usage Classes

The UL325 standard covers gate operators. Within this safety standard several Usage Classes are described that define different types of installations where gate operators can be applied. Some operators are restricted in their usage application. All Nice USA operators are approved for use in all four UL325 Usage Classes. Appropriate Usage Classes are shown in the Specifications.

2.1.1 Class I Residential Gate Operator. Intended for use in a location of one to four single family dwellings or a parking area associated with one to four single family dwellings.



2.1.2 Class II Commercial / General Access Gate Operator. Intended for use in a commercial location or building such as a multi-family housing units (five or more single family units) hotels, garages, retail stores or other buildings servicing general public.



2.1.3 Class III Industrial / Limited Access Gate Operator. Intended for use in an industrial location or building such as factories or loading docks or other locations not intended to service general public.

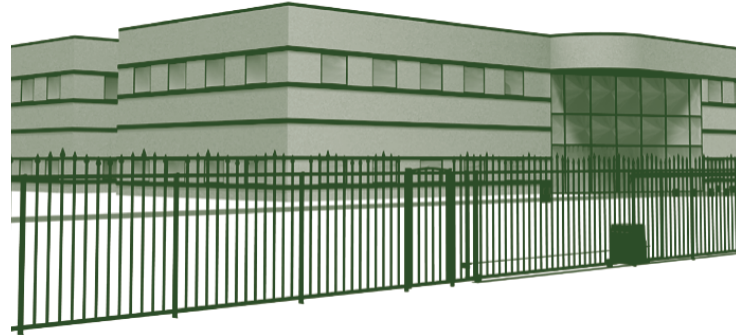

2.1.4 Class IV Restricted Access Gate Operator. Intended for use in guarded industrial locations or buildings such as an airport security area or other restricted access location, not servicing general public, in which access is monitored by security personnel or via closed circuitry.

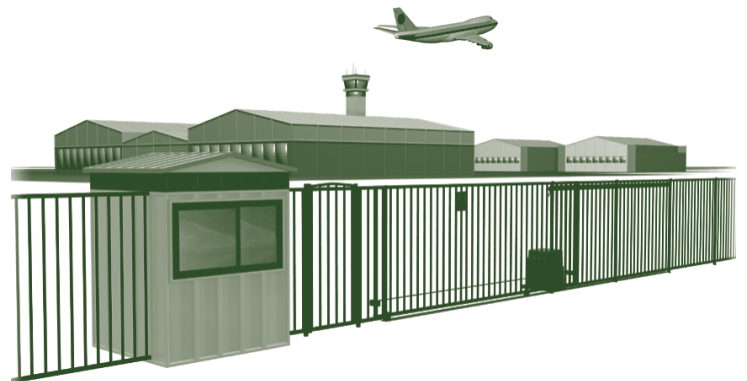

2.2 Vehicular Traffic Only

This automatic gate operator is not designed nor is it intended for pedestrian traffic. Vehicular gate operators must by their nature be powerful to function reliably. This power can cause injury or death. Accordingly, direct all pedestrian traffic to a separate walk-through gate.

2.3 Install This Gate Operator Only When:

- a. The operator is appropriate for the construction of the gate and the usage Class of the gate,
 - b. All openings of a horizontal slide gate are guarded or screened from the bottom of the gate to a minimum of 1.83 m (6 ft) above the ground to prevent a 57.2 mm (2-1/4 inch) diameter sphere from passing through the openings anywhere in the gate, and the portion of the adjacent fence that the gate covers in the open position,
 - c. All exposed pinch points are eliminated or guarded, and
 - d. Guarding is supplied for exposed rollers.
- 2.4 The operator is intended for installation only on gates used for vehicles. Pedestrians must be supplied with a separate access opening. The pedestrian access opening shall be designed to promote pedestrian usage. Locate the gate such that persons will not come in contact with the vehicular gate during the entire path of travel of the vehicular gate.
- 2.5 The gate must be installed in a location so that enough clearance is supplied between the gate and adjacent structures when opening and closing to reduce entrapment risk. Swinging gates shall not open into public access areas
- 2.6 The gate must be properly installed and work freely in both directions prior to gate operator installation. Don't change operator settings to compensate for an improperly installed, improperly functioning, or damaged gate.

2.7 Permanently mounted controls intended for user activation must be located at least 1.83 m (6 ft) away from any moving part of the gate and where the user is prevented from reaching over, under, around or through the gate to operate the controls. Exception: Emergency access controls only accessible by authorized personnel (e.g. fire, police, EMS) may be placed at any location in the line-of-sight of the gate.

2.8 A Stop and/or Reset button must be located in the line-of-sight of the gate. Activation of the reset control shall not cause the operator to start.

2.9 A minimum of two (2) WARNING SIGNS shall be installed, in the area of the gate. Each placard is to be visible by persons located on the side of the gate on which the placard is installed.

2.10 When utilizing a Nice 1050 board, a maximum of 10 entrapment protection devices may be connected.

2.11 For gate operators utilizing a non-contact sensor (Photo Eye):

- a. See instructions on the placement of non-contact sensors for each type of application,
- b. Care shall be exercised to reduce the risk of nuisance tripping, such as when a vehicle, trips the sensor while the gate is still moving, and
- c. One or more non-contact sensors shall be located where the risk of entrapment or obstruction exists, such as the perimeter reachable by a moving gate or barrier.

2.12 For a gate operator utilizing a contact sensor (Edge):

- a. One or more contact sensors shall be located where the risk of entrapment or obstruction exists, such as at the leading edge, trailing edge, and postmounted both inside and outside of a vehicular horizontal slide gate.
- b. A hardwired contact sensor shall be located and its wiring arranged so that the communication between the sensor and the gate operator is not subjected to mechanical damage.
- c. A wireless device such as one that transmits radio frequency (RF) signals to the gate operator for entrapment protection functions shall be located where the transmission of the signals are not obstructed or impeded by building structures, natural landscaping or similar obstruction. A wireless device shall function under the intended end-use conditions.
- d. One or more contact sensors shall be located on the inside and outside leading edge of a swing gate. Additionally, if the bottom edge of a swing gate is greater than 152 mm (6 in) but less than 406 mm (16 in) above the ground at any point in its arc of travel, one or more contact sensors shall be located on the bottom edge.

3. Use of Vehicle Detectors

Use of vehicle detectors (loop detectors) is strongly encouraged to prevent damage to vehicles caused by gates closing on them. This is not considered to be a safety item as vehicle detectors cannot provide protection to pedestrians. In some situations, photoelectric devices may be used as vehicle detectors, but should be wired accordingly.

4. Gate Construction and Safety

Gate construction plays a very important role in ensuring the safety of any automated gate system. The standard for gate construction is ASTM F2200. Below are key areas to address safety in gate design. For complete information consult the standard. Copies of the standard are available at: <https://www.astm.org/Standards/F2200.htm>

Another source of information is available from DASMA, the Door and Access System Manufacturer's Association. The Association publishes Technical Data Sheets, one of which concerns ASTM F2200. For more information, see: <http://www.dasma.com/PDF/Publications/TechDataSheets/OperatorElectronics/TDS370.pdf>

4.1 General Requirements for gate construction

- 4.1.1 Gates shall be constructed in accordance with the provisions given for the appropriate gate type listed. Refer to ASTM F2200 for additional gate types.
- 4.1.2 Gates shall be designed, constructed and installed to not fall over more than 45 degrees from the vertical plane, when a gate is detached from the supporting hardware.
- 4.1.3 Gates shall have smooth bottom edges, with vertical bottom edged protrusions not exceeding 0.50 in. (12.7 mm) when other than the Exceptions listed ASTM F2200.
- 4.1.4 The minimum height for barbed wire shall not be less than 6 ft. (1.83 m) above grade. The minimum height for barbed tape shall not be less than 8 ft. (2.44 m) above grade.
- 4.1.5 An existing gate latch shall be disabled when a manually operated gate is retrofitted
- 4.1.6 A gate latch shall not be installed on an automatically operated gate.
- 4.1.7 Protrusions shall not be permitted on any gate. Consult ASTM F2200 for exceptions.
- 4.1.8 Gates shall be designed, constructed and installed such that their movement shall not be initiated by gravity when an automatic operator is disconnected.

4.1.9 For pedestrian access in the vicinity of an automated vehicular gate, a separate pedestrian gate shall be provided. The pedestrian gate shall be installed in a location such that a pedestrian shall not come in contact with a moving vehicular access gate. A pedestrian gate shall not be incorporated into an automated vehicular gate panel.

4.1.10 Any non-automated gate that is to be automated shall be upgraded to conform to the provisions of this specification.

4.1.11 This specification shall not apply to gates generally used for pedestrian access and to vehicular gates not to be automated.

4.1.12 Any existing automated gate, when the operator requires replacement, shall be upgraded to conform to the provisions of this specification in effect at that time.

4.2 Vehicular Horizontal Slide Gate Requirements

4.2.1 The following provisions shall apply to Class I, Class II and Class III vehicular horizontal slide gates:

4.2.1.1 All weight bearing exposed rollers 8 ft (2.44 m), or less, above grade shall be guarded or covered

4.2.1.2 All openings shall be designed, guarded, or screened from the bottom of the gate to the top of the gate or a minimum of 72 in. (1.83 m) above grade, whichever is less, to prevent a 2 1/4 in. (57 mm) diameter sphere from passing through the openings anywhere in the gate, and in that portion of the adjacent fence that the gate covers in the open position. The gate panel shall include the entire section of the moving gate, including any back frame or counterbalance portion of the gate.

4.2.1.3 A gap, measured in the horizontal plane parallel to the roadway, between a fixed stationary object nearest the roadway (such as a gate support post) and the gate frame when the gate is in either the fully open position or the fully closed position, shall not exceed 2 1/4 in. (57 mm). Exception: All other fixed stationary objects greater than 16 in. (406 mm) from the gate frame shall not be required to comply with this section.

4.2.1.4 Positive stops shall be required to limit travel to the designed fully open and fully closed positions. These stops shall be installed at either the top of the gate, or at the bottom of the gate where such stops shall horizontally or vertically project no more than is required to perform their intended function.

4.2.1.5 All gates shall be designed with sufficient lateral stability to assure that the gate will enter a receiver guide. Consult ASTM F2200 for details on various gate panel types.

4.2.2 The following provisions shall apply to Class IV vehicular horizontal slide gates:

4.2.2.1 All weight bearing exposed rollers 8 ft (2.44 m), or less, above grade shall be guarded or covered.

4.2.2.2 Positive stops shall be required to limit travel to the designed fully open and fully closed positions. These stops shall be installed at either the top of the gate, or at the bottom of the gate where such stops shall horizontally or vertically project no more than is required to perform their intended function.

4.3 Vehicular Horizontal Swing Gates

4.3.1 The following provisions shall apply to Class I, Class II, and Class III horizontal swing gates:

4.3.2 Gates shall be designed, constructed and installed so as not to create an entrapment area between the gate and the supporting structure or other fixed object when the gate moves toward the fully open position, subject to the following provisions.

4.3.3 The width of an object (such as a wall, pillar or column) covered by a swing gate when in the open position shall not exceed 4 in. (102 mm), measured from the centerline of the pivot point of the gate. Exception: For a gate that is not in compliance with this provision, the defined area shall be subject to the entrapment protection provisions of UL 325.

4.3.4 Except for the zone specified in 4.3.3 the distance between a fixed object such as a wall, pillar or column, and a swing gate when in the open position shall not be less than 16 in. (406 mm). Exception: For a gate that is not in compliance with this provision, the defined area shall be subject to the entrapment protection provisions of UL 325.

4.3.5 Class IV vehicular horizontal swing gates shall be designed, constructed and installed in accordance with security related parameters specific to the application in question.

5. Maintenance of Gate Systems

To keep your automated gate system performing both safely and reliably it is important to ensure that the components of that system are functioning properly. At least monthly:

5.1 Disconnect the gate operator and manually move the gate through its range of travel. Note any squeaks from rollers or hinges or areas of binding. The gate should travel smoothly and quietly throughout its range. If it does not, contact a gate professional to correct the problem.

5.2 Reconnect the gate operator and perform the following tests:

5.2.1 With the gate opening, block any photo eyes and/or depress any safety edges used to protect the open direction. The gate should stop, or, stop and reverse.

5.2.2 With the gate closing, block any photo eyes and/or depress any safety edges used to protect the close direction. The gate should stop, or, stop and reverse.

5.2.3 Using a suitable obstruction in the path of the gate (a solid, immovable object), run the gate in the open direction until it contacts the obstruction. The gate should stop and reverse.

5.2.4 Using a suitable obstruction in the path of the gate (a solid, immovable object), run the gate in the close direction until it contacts the obstruction. The gate should stop, or, stop and reverse.

6. Entrapment Protection

The UL325 standard for gate operators requires a minimum of two independent entrapment protection means for each entrapment zone. An entrapment zone is defined as follows:

For slide gates, any locations between a moving gate and a counter opposing edge or surface where entrapment is possible up to a height of 6 ft. (1.83m) above grade. Such locations occur if at any point in travel the gap between a moving gate and the fixed counter opposing edges or surfaces is less than 16 in. (406mm).

For swing gates, locations between a moving gate or moving, exposed operator components and a counter opposing edge or surface where entrapment is possible up to 6 ft (1.83m) above grade. Such locations occur if during any point in travel:

- The gap between the bottom of a moving gate and the ground is greater than 4 in. (101.6 mm) and less than 16 in. (406 mm); or
- The distance between the center line of the pivot and the end of the wall, pillar, or column to which it is mounted when in the open or closed position exceeds 4 in. (101.6 mm). Any other gap between a moving gate and fixed counter opposing edges or surfaces or other fixed objects is less than 16 in. (406 mm) (examples are walls, curbs, berms or other immovable objects).

Potential entrapment zones are shown in image below for swing gates, but keep in mind there may be other entrapment zones presented by the actual installation and adjacent structures or landscape that must be protected as well.

Possible Entrapment Zones - Typical Installation Diagram Utilizing Photocells

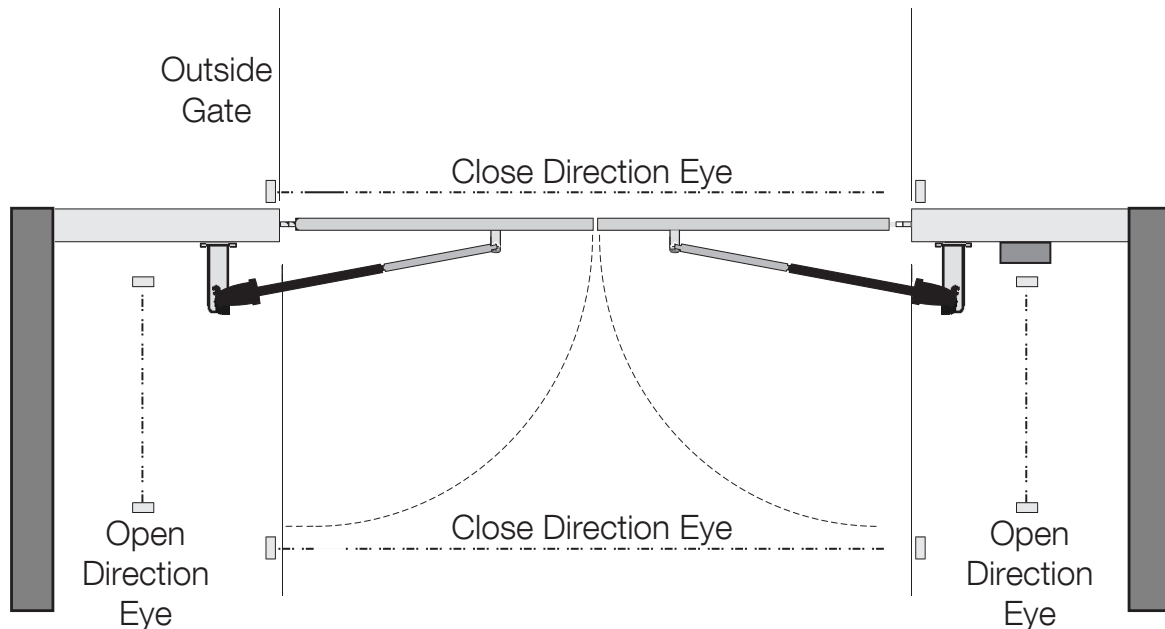

(Possible Entrapment Zone if gate opens to <16 inches from wall or fixed object)

(Possible Entrapment Zone if gate opens to <16 inches from wall or fixed object)

Swing Gate Possible Entrapment Zones

All Nice gate operators feature an Inherent Entrapment System (IES) (UL325 Type A) that monitors the force on the gate during travel. This system protects in both the open and close direction and reverses on contact with an obstruction. This IES system serves as one of the means of entrapment protection.

External sensors must be used to protect against entrapment at each location where an entrapment zone exists. The minimum number of external sensors required to enable automatic operation of the gate operator is as follows:

- Swing Gates: One sensor in the Close direction (provided the gate in the open direction presents no risk of entrapment.)
- Slide Gates: One sensor in the Open direction and one sensor in the Close direction.

The gate operator tests for the presence of these sensors, and if the required minimum number is not found, the operator will only run using continuous pressure on an Open/Close button, either on the controller, or an external device.

7. **Compatible External Sensors**

Only the following external sensors have been evaluated and tested with Nice gate systems and are approved to be used for protection against entrapment:

- Nice BlueBus Through-Beam Photo Eye
- EMX IRB-RET Retro-reflective Photo Eye
- ASO Sentir Series Contact Edge
- Miller Edge GEM-103 Edge Sensor Converter
- EMX WEL-200 Wireless Edge Transmitter/Receiver

8 - PARTS IDENTIFICATION



Control Box
CBOX1050



816 - Actuator with 12' harness

816X - Actuator with 42' harness



Pivot Arm #1116



Gate attach bracket
#10025215



Bolt kit
#1125

9 - PULL TO OPEN INSTALLATION

IMPORTANT - Never weld parts to the gate or posts when the operator circuit board is powered. Doing so may damage the board beyond repair.

9.1 - PIVOT ARM INSTALLATION - Location of Pivot Point

The following instructions provide up to 105° of swing.

Measurements are taken from the center of the gate hinge.

The pivot arm needs to be securely mounted to the hinge post or equivalent mounting surface. It is recommended to weld the pivot arm to a metal post. In order to achieve the correct articulation, geometry and rate of speed of the gate it is critical that the measurements below are followed. The pivot arm may need to be cut to achieve the correct placement of the actuator mounting hole. Measurements are taken from the center of pivot of the gate hinge.

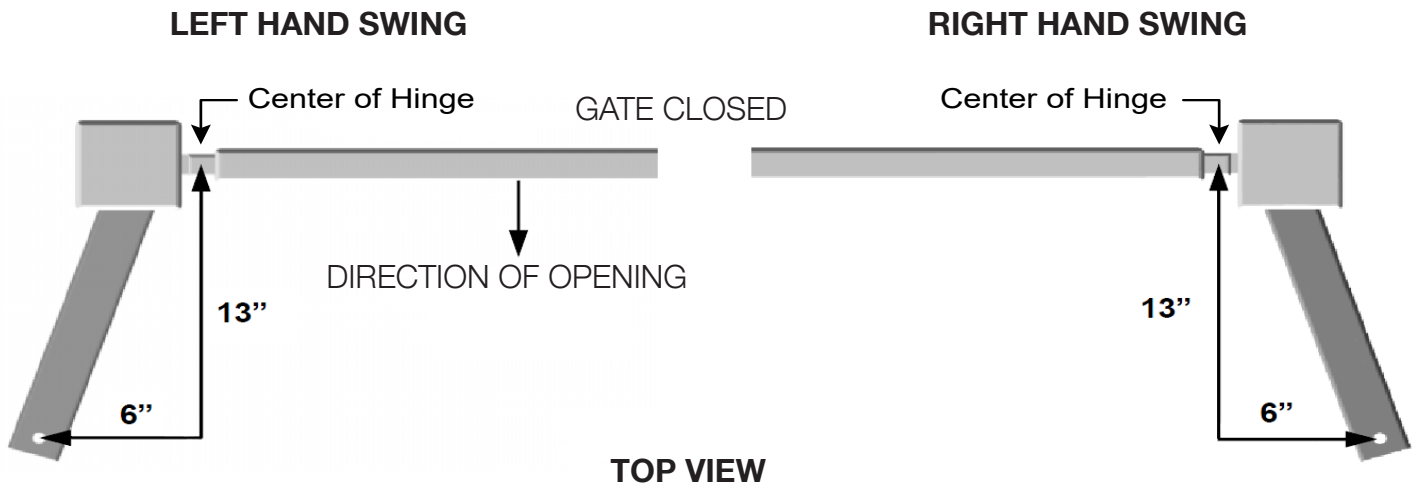

NOTE: If you have columns built around your gate hinge post, check these measurements for proper clearance before proceeding with this pull to open installation.

9.2 - Vertical position of pivot arm

The top edge of the Pivot Arm will be located 1/2" below the center line for the gate bracket. The Pivot Arm must be level when secured.

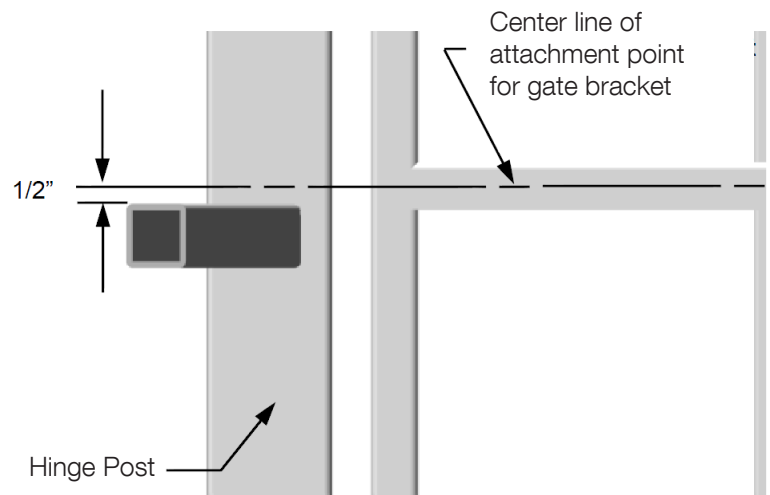

10 - PUSH TO OPEN INSTALLATION

10.1 - PIVOT ARM INSTALLATION - Location of Pivot Point

Measurements are taken from the center of pivot of the gate hinge.

The pivot arm needs to be securely mounted to the hinge post or equivalent mounting surface. It is recommended to weld the pivot arm to a metal post. In order to achieve the correct articulation, geometry and rate of speed of the gate it is critical that the measurements below are followed. The pivot arm may need to be cut to achieve the correct placement of the actuator mounting hole. Measurements are taken from the center of pivot of the gate hinge.

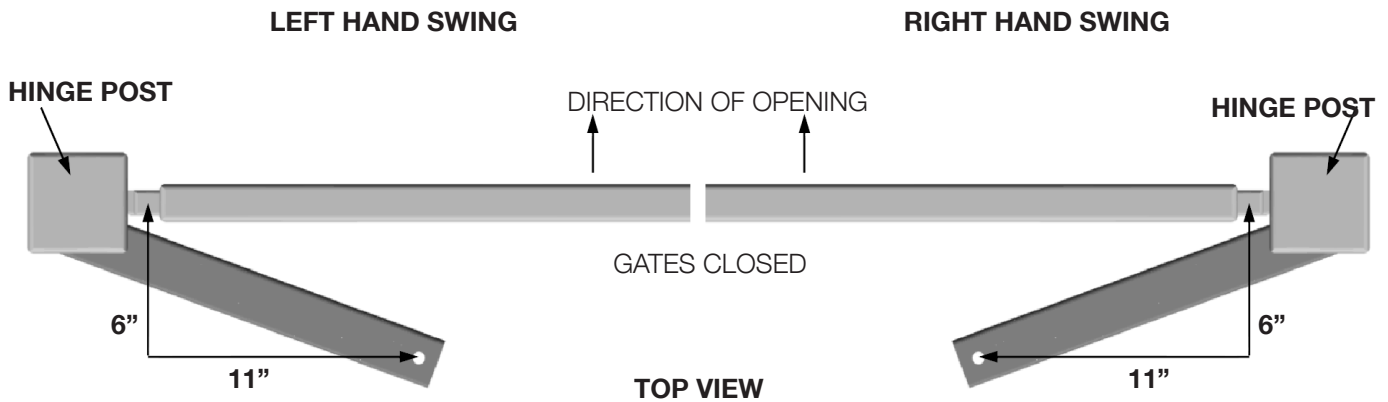

10.2 - Vertical position of pivot arm

The top edge of the Pivot Arm will be located 1/2" below the center line for the gate bracket. The Pivot Arm must be level when secured.

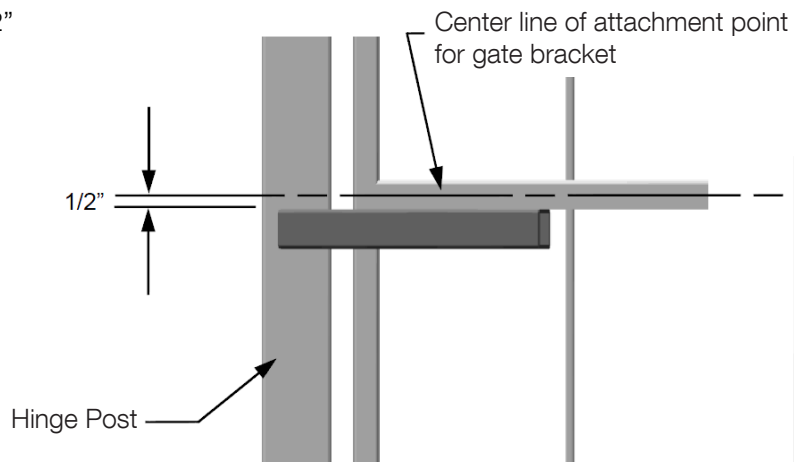

11 - ACTUATOR MOUNTING

Mount the actuator to the pivot arm as shown.

Please notice the washer goes above the actuator flange.

The lock nut should be tight to prevent movement or shifting when the actuator is running. This will also prevent excessive "bounce" or "wobble" when the gate stops moving.

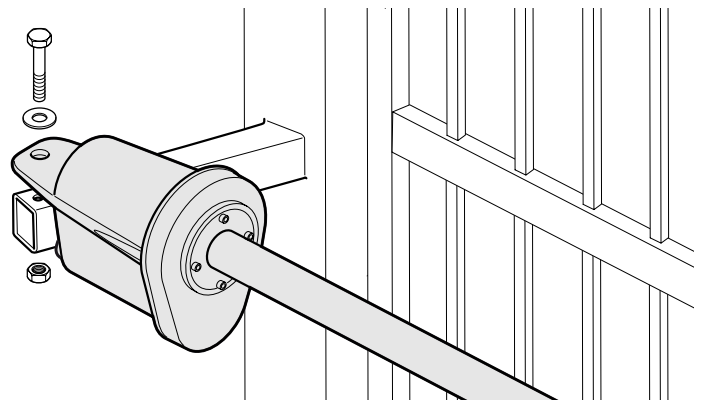

12 - CONTROL BOX MOUNTING

Mount the control box at least 6 feet from any moving part of the gate. There is 12 feet of cord provided for mounting flexibility. Use mounting hardware capable of supporting the weight of the control box with the battery installed.

Do not mount the control box where the person using the push button on side of the box can come in contact with the gate.

Set battery inside of control box with terminals toward the front (Do not use any battery with side terminals).

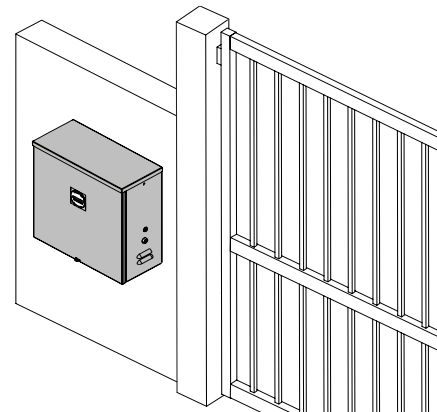

13 - 1050 CIRCUIT BOARD LAYOUT

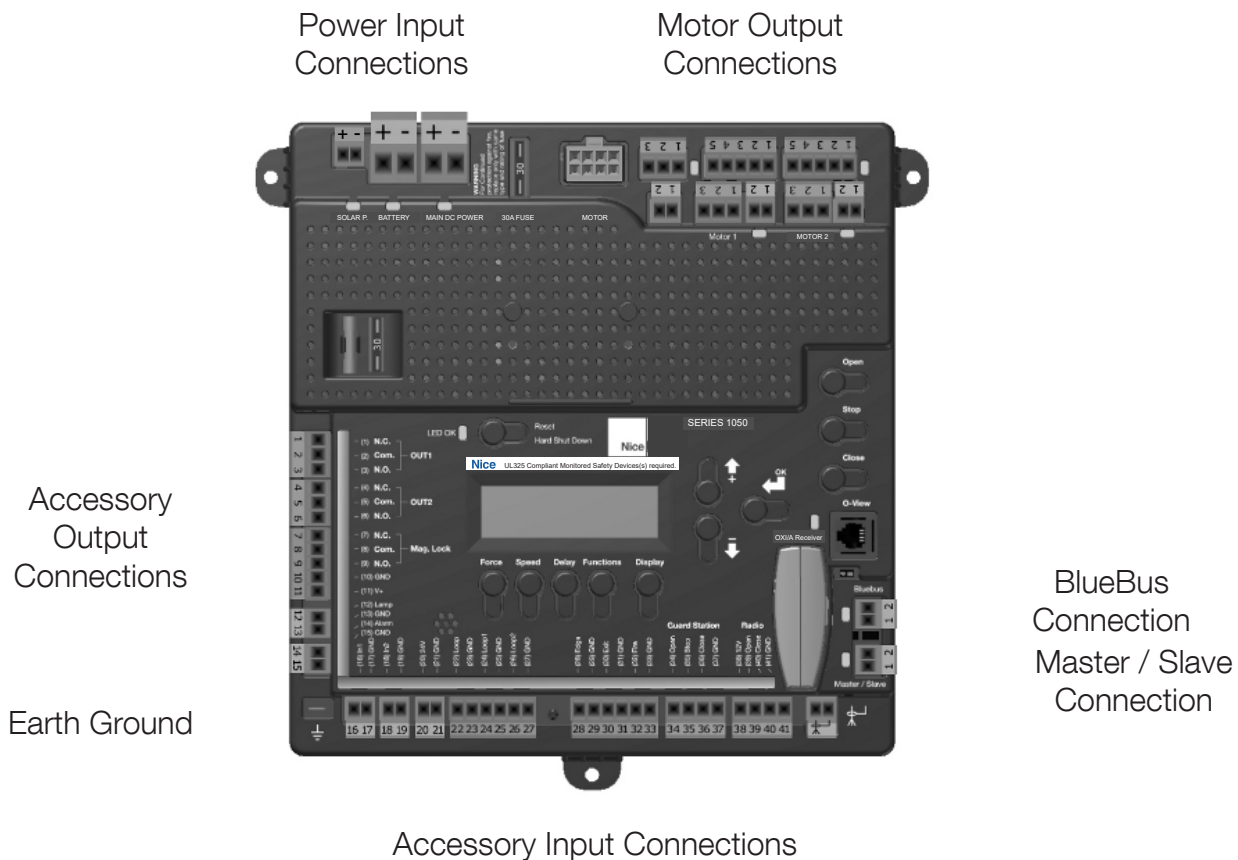

14 - INCOMING POWER WIRING

Power input connections should be wired as follows:

Solar Panel

Connect wires to the solar panel terminal block. The positive wire of the panel connects to the left terminal marked "+".
Note: If the panel is connected backwards a red LED will illuminate below the terminal. If solar power is to be used it will be necessary to program control board for STANDBY operation. See section 16 for information on STANDBY mode.

Battery

Connect wires to the battery terminal block. The positive wire of the battery connects to the left terminal marked "+".
Note: If the battery is connected backwards a red LED will illuminate below the terminal.

Main DC Power - This terminal block is for incoming 10-35VDC power only!

Connect wires to the main power terminal block. Positive of the power supply connects to the left terminal marked "+". This input should only be used with a power supply capable of supplying 10-35VDC at 20 amps.

Note: Main DC Power input is only used on commercial operators. No connections will be made on the 1551 operator.

Note: If supply is connected backwards a red LED will illuminate below the terminal. If supply is connected properly a green LED will illuminate.

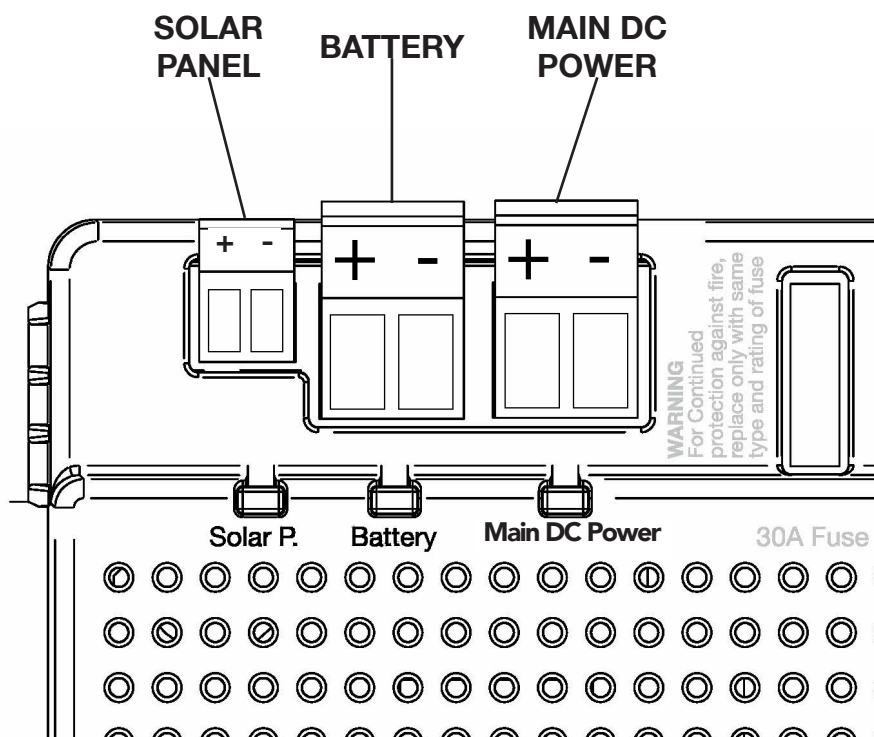

15 - ACTUATOR WIRING

15.1 - 1050 Control Board Wiring (Single and Dual Gate Application)

15.1.1 - 816 ACTUATOR WIRING (PULL TO OPEN)

816 limit switch and smart sensor wiring

Connect the Nice 816 actuator cable to the 5-pin connector as shown below. These connections enable the Nice 816 limit switch and smart sensor inputs into the gate controller.

Nice actuator motor wiring

Connect the Nice 816 actuator motor leads to the 3-pin connector as shown below.

Note: If the gate moves in the opposite direction from what is expected, reverse the actuator wiring from what is shown. (Red to Pin 1, Black to Pin 3).

Install the 5 and 3-pin connector into the connection labeled "Motor 1" on the controller. Install the 5 and 3-pin and connector into the connection labeled "Motor 2" for a dual leaf swing gate installation. For dual actuators, the actuator with the shorter cable must plug into Motor 1 connections.

816 ACTUATOR SINGLE MOTOR - PULL TO OPEN

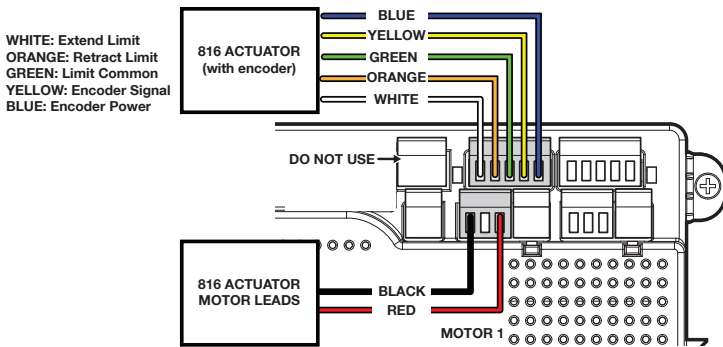

816 ACTUATOR SINGLE MOTOR - PUSH TO OPEN

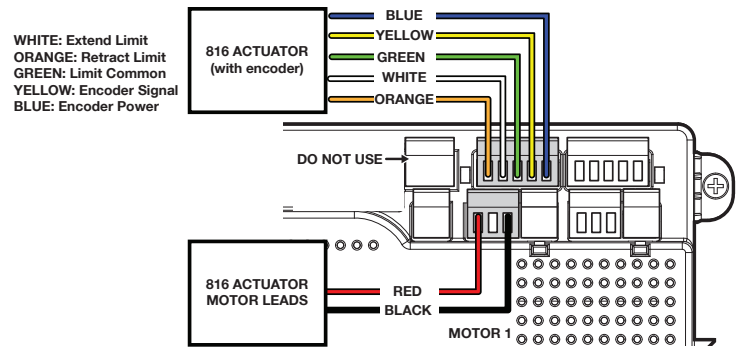

816 ACTUATOR DUAL MOTOR - PULL TO OPEN

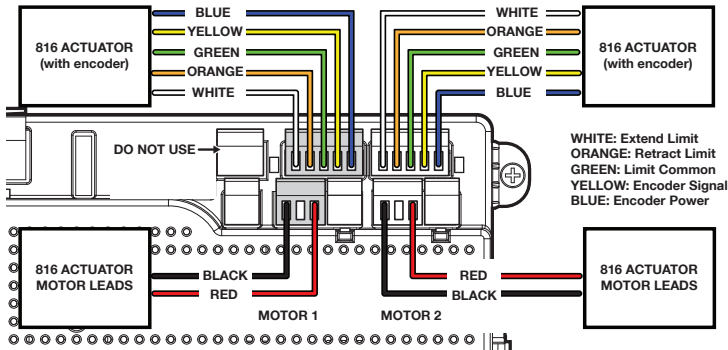

816 ACTUATOR DUAL MOTOR - PUSH TO OPEN

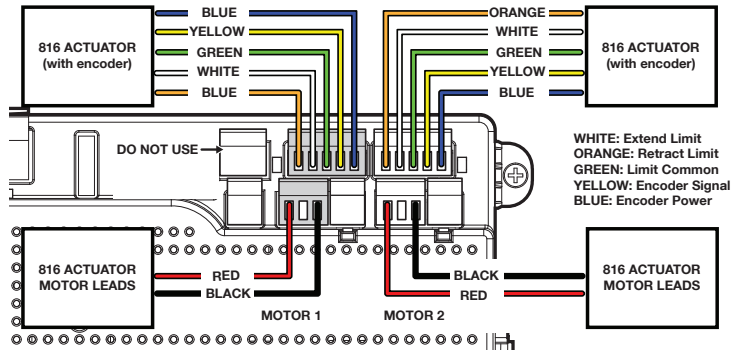

16 - GATE BRACKET MOUNTING

Pull to Open only: Activate push button on the side of the control box and extend the actuator until it stops (leave actuator retracted for PUSH TO OPEN).

WARNING: Do not let extension tube rotate as it extends. Do not insert fingers or tools in the hole at the end of the extension tube.

Connect the gate bracket to the end of the extension tube with supplied 1/2" x 3" bolt. With the gate in the closed position, place the gate bracket on the gate and mark placement or secure with a clamp. Unbolt and remove the extension tube from the bracket and weld or bolt the bracket to the gate using 3/8" bolts, lock washers, and nuts.

Bolt the actuator to the gate bracket as shown.

Tip: Tack weld or C clamp at first if uncertain about location. Run the unit through a complete cycle to insure proper operation then mount permanently.

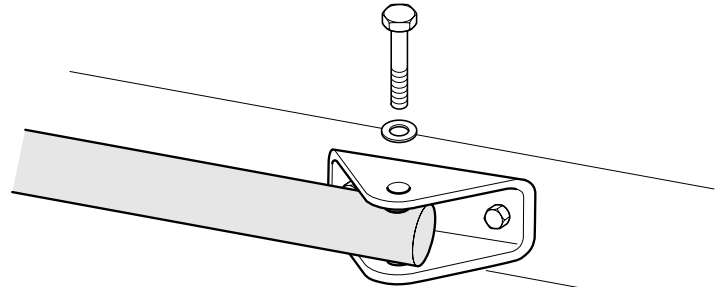

17 - LIMIT SWITCH ADJUSTMENT

Remove the limit screw end caps as shown in the figure to the right.

NOTE: Do not extend the extension tube too far or you will risk unscrewing the tube from the main drive screw. The maximum extended length of the actuator is 66" (hole to hole).

EXTEND more: Turn the limit screw counterclockwise

EXTEND less: Turn the limit screw clockwise

RETRACT more: Turn the limit screw clockwise

RETRACT less: Turn the limit screw counterclockwise

Remove limit switch end caps

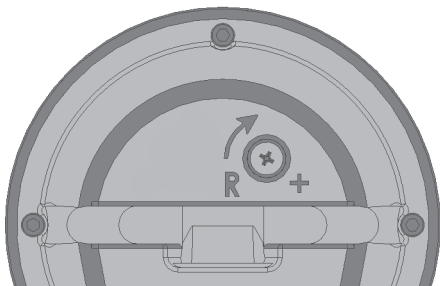
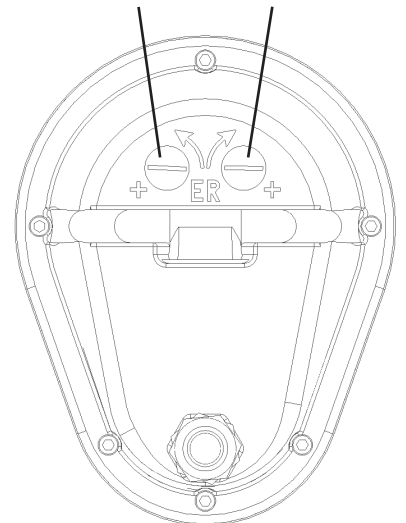

RETRACT more:
Turn the limit screw clockwise

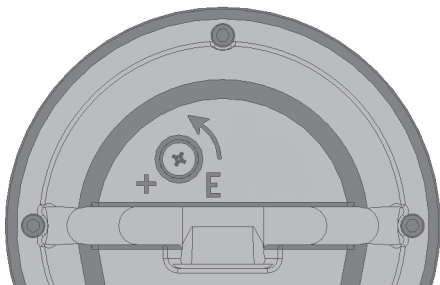

RETRACT less:
Turn the limit screw counterclockwise

EXTEND more:
Turn the limit screw counterclockwise

EXTEND less:
Turn the limit screw clockwise

Extend limit screw Retract limit screw

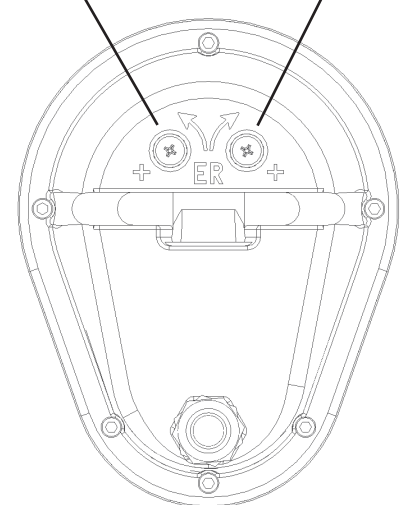

18 - SETTING THE LIMIT SWITCHES

When first powered on, the board will scan for any BlueBus photo eyes connected. If at least one eye is not detected, then one of the auxiliary inputs must be programmed to either pulse open or pulse close, with an External Entrapment sensor connected before learn mode is initiated.

NOTE: The control board is already in the "LEARN MODE" when shipped. You are in LEARN MODE if the word "ENTER" is flashing below "LEARN".

If the board is not in "LEARN MODE", press:

FUNCTION → OK → SWING → OK → LIGHT → OK
AVERAGE
HEAVY

You are in LEARN MODE if "ENTER" is flashing.

For dual gate installations - set one motor at a time.

OPEN LIMIT

Green OPEN LED

1. Using the OPEN button on the front of the Control Board, hold the button down until the gate reaches the fully intended open position.
2. Adjust the Open Limit on the operator until the GREEN light illuminates on the front of the control board as shown above. The fully OPEN limit switch is now set.

Note: If red LED illuminates, reverse orange and white limit wires

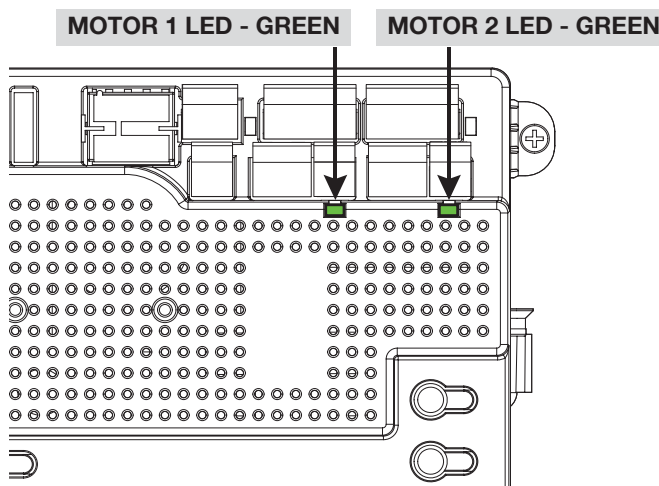

CLOSE LIMIT

Red CLOSE LED

1. Using the CLOSE button on the front of the Control Board, hold the button down until the gate reaches the fully extended closed position.
2. Adjust the Closed Limit on the operator until the RED light illuminates on the front of the control board as shown above. The fully CLOSED limit switch is now set.

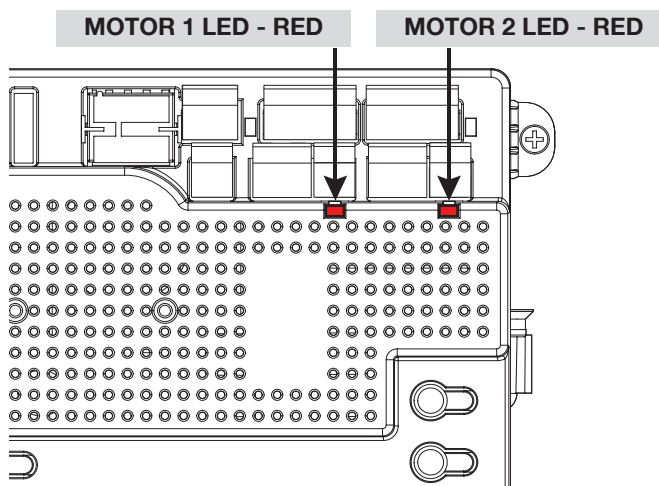

19 - LEARNING MODE

Nice has taken great care to simplify the installation, operation and safety of this device and to ensure longevity and reliability of the unit over time. The learning procedure consists of the following steps shown below:

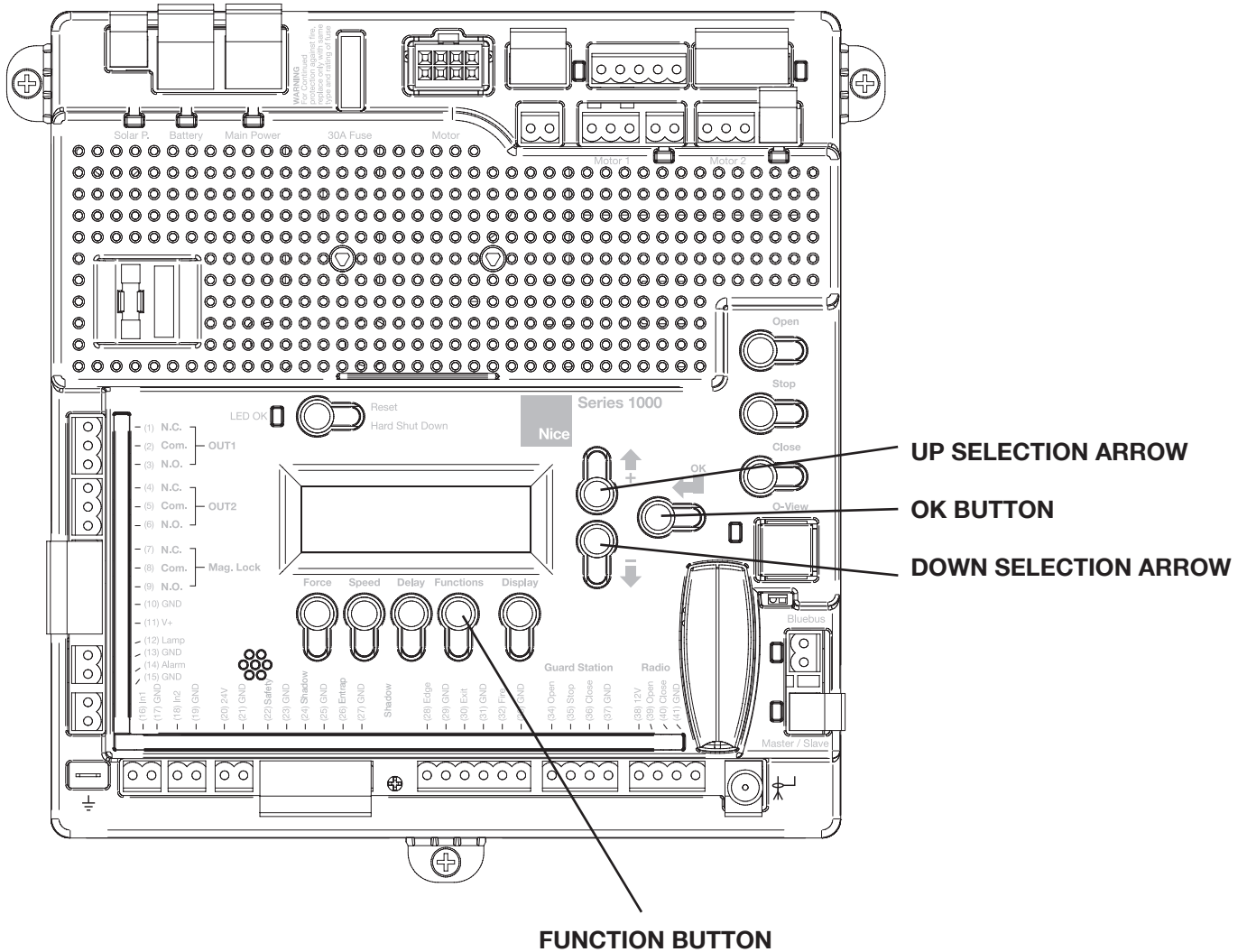

NOTE: The control board is already in the “LEARNING MODE” when shipped.

If the board is not in “LEARN MODE”, press:

FUNCTION → OK → SWING → OK → LIGHT → OK
 AVERAGE
 HEAVY

You are in LEARN MODE if "ENTER" is flashing.

1. Test the motor direction by pressing and holding CLOSE. If the gate instead OPENS swap the RED and BLACK motor leads and retest to verify correct operation. Set limits according to the operators installation manual. **Limits and motor direction MUST be set prior to learning the board!**
2. Press and hold the OPEN or CLOSE button on the gate controller until the gate is 50% open.
3. Press OK to allow the control board to scan for the required monitored entrapment devices. If they are not present, "BLUEBUS ERROR" will be displayed and start the learning sequence. The gate will open partially then stop. This is being done, so that the control board can sense the type and operational condition of the drive motor. The gate will then run to the close limit (one leaf at a time in case of dual application: Motor2 closes first then Motor1 follows), so that it can properly sense the close limit switch. The gate will then fully open to test the open limit switch then fully close at high speed. The gate should be fully learned by the control board at this point.

The gate operator is now programmed for basic usage.

20 - ACCESSORY INPUTS AND OUTPUTS

20.1 - Outputs

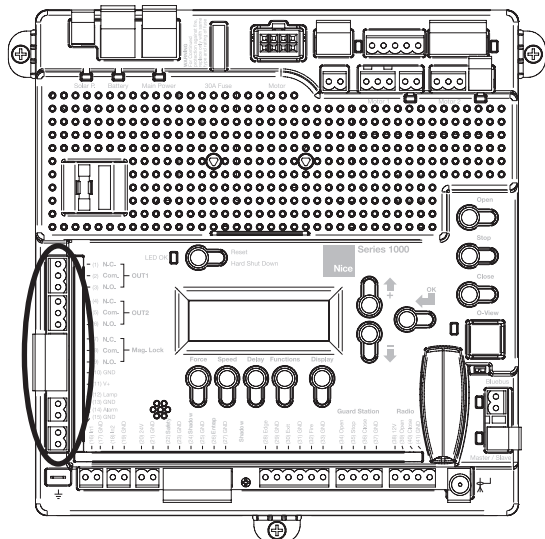

Figure - BOARD OUTPUTS

GATE OPERATOR ACCESSORY OUTPUTS:

OUT1 and OUT2: Individual, isolated relays provide COMMON, NORMALLY OPEN, and NORMALLY CLOSED dry contacts for switching accessories based on programming of the "Auxiliary IO" function. These outputs are programmed in the "FUNCTION Auxiliary I/O" menu.

Magnetic Lock: Provides fused power (1.85A max) and isolated relay COMMON, NORMALLY OPEN, and NORMALLY CLOSED dry contacts for electrically powered and maintained magnetic locks. The output time for magnetic lock activation/deactivation may be adjusted from 0 to 5 seconds.

Lamp: Provides fused power (1.85A max) to drive a flashing warning lamp to indicate gate operation. This output is active when the gate is operating (Opening and Closing). Lamp Delay sets the amount of time the lamp accessory output is activated prior to gate movement. Settings from 0 to 5 seconds with a step of 0.5 seconds.

Alarm: Provides fused power (0.5A @ 12VDC) to drive an alarm siren to signal the occurrence of a hard shutdown, caused by 2 consecutive entrapment events (signals). This alarm output is reset by pressing the "Reset Hard Shutdown" button on the front panel or activating the "FIRE" input.

20.2 - Inputs

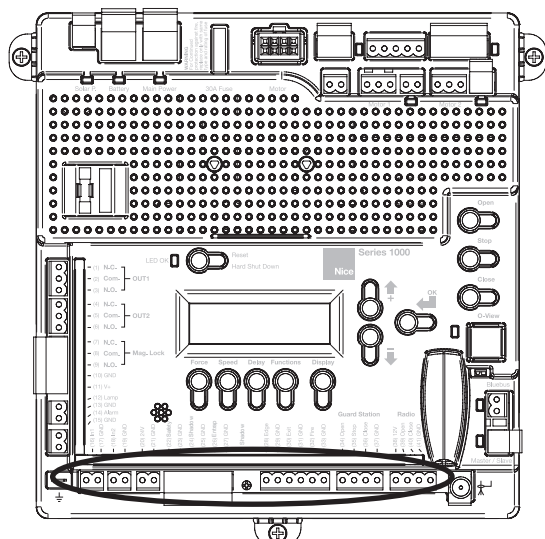

Figure - INPUTS

GATE OPERATOR ACCESSORY INPUTS:

Auxiliary Inputs 1 (16), 2 (18): These digital inputs may be connected to the digital outputs of accessories and programmed to activate or control the gate operator in a number of different modes. Shorting the pins through a dry contact activates the programmed settings for these inputs. These inputs are programmed in the "FUNCTION Auxiliary I/O" menu.

SAFETY Input: (22) Dry contact input that can be programmed for an inductive loop or photo-eye detector. Shorting the Safety Input (22) to GND reverses a closing gate to the full open position. The opened gate is held open for as long as the input is active. This input is not for external entrapment sensors.

SHADOW Input: (24) Dry contact input that can be programmed for an inductive loop or photo-eye detector. Shorting the Shadow Input (24) to GND maintains an OPEN gate fully open and a CLOSED gate fully closed until deactivated.

Setting the Shadow Input to "Photo Mode" causes the opening gate to stop, then reopens the gate when the Shadow Input is deactivated.

ENTRAP Input: (26) Dry contact input that can be programmed for an inductive safety loop or photo-eye detector. Shorting the ENTRAP input (26) to GND while the gate is opening cause the gate to close to the fully closed position. This input is not for external entrapment sensors.

EDGE Input: (28) This input may be configured as "DIGITAL" NO or "ANALOG" as required by the sensor type. When configured as "DIGITAL", this is a dry contact input. When configured as "Analog", there are additional options for the direction of travel it is intended to protect: Open, Close, or Both (swing only). When configured as "Analog" the input must measure an 8.2K - 10K ohm resistor. When the input is activated and set to Digital, the gate stops and reverses regardless of direction. If set to "Analog" the gate will only reverse if tripped while going in the programmed direction..

EXIT Input: (30) Dry contact input for a vehicle exit sensor. Shorting the EXIT input to GND opens gate from the closed position and holds gate open with maintained input or reverses gate if closing.

FIRE Input: (32) Dry contact input for a fire department control switch. Shorting the Fire input (32) to GND opens the gate and holds the gate open until the control switch is deactivated. This input is "hold to run". Auto-close is disabled when this input is activated. Also clears hard shutdown.

GUARD STATION

Guard Station OPEN: (34) Dry contact input for a guard station open switch. Momentarily shorting the Open input (34) to GND opens the gate to the full open position with the subsequent auto-close feature enabled.

Guard Station STOP: (35) Dry contact input (Normally Closed) for a guard station stop switch. Momentarily opening the Stop input (35) stops the opening gate at its current position. While this input is activated, all other inputs are disabled and are not functional.

Guard Station CLOSE: (36) Dry contact input for a guard station close switch. Momentarily shorting the Close input (36) to GND closes the gate (master and slave).

RADIO

Radio Open: (39) Dry contact input for an accessory radio open switch. Momentarily shorting the Open input (39) to GND opens the gate to the full open position with the subsequent auto-close feature enabled.

Radio Close: (40) Dry contact input for an accessory radio close switch. Momentarily shorting the Close input (40) to GND closes the gate.

Radio Input: Open/Close: (39 and 40) If you tie open and close together the unit will operate as a Step by Step command each time the input is shorted to GND, it will either OPEN, STOP or CLOSE.

20 - ACCESSORY INPUTS AND OUTPUTS (CONT.)

Deleting all Nice transmitters from the Nice Plug-In Receiver Memory.

All programmed remote controls may be removed from the Nice plug in receiver memory. This procedure needs to be performed at the gate controller.

1. Press and hold the button on the side of the Nice receiver until the led on the Nice receiver illuminates green and keep the button pressed.
2. Watch the led and on the receiver and verify the following sequence in the led.
3. Within 4 seconds after pressing the button (approx.) the green led illuminates.
4. Within 8 seconds after pressing the button (approx.) the green led turns off.
5. Within 12 seconds after pressing the button (approx.) the green led starts flashing
6. Count the green led flashes on the Nice receiver. On EXACTLY the 3rd flash, release the button on the Nice receiver.
7. It is recommended to test the Nice remote controls, if available, with Nice plug in receiver to verify that it no longer affects the gate controller.

21 - 120VAC POWER WIRING

DO NOT WIRE AC POWER TO THE 1050 CONTROL BOARD!

THE CONTROL BOARD OPERATES ON 10 - 32 VDC ONLY!

This section is intended for residential systems where a 120VAC transformer will be used

To reduce the risk of SEVERE INJURY or DEATH:

- Disconnect power to the gate operator by manually opening its dedicated circuit breaker before making any mechanical or electrical adjustments.
- Use a 20 Amp dedicated circuit breaker for each installed gate operator.
- Open dedicated circuit breaker supplying power to gate operator BEFORE a new installation or making any modifications to an existing installation of this gate operator.
- All wiring connections MUST be made by a qualified individual
- Run individual circuits in separate U.L. listed conduits. Do not combine high voltage (120VAC) power wiring and low voltage (+12VDC to +24VDC) control wiring in the same conduits.
- Use the information in Table 1 to determine high voltage wire size requirements. The distance shown in the chart is measured in feet from the operator to the power source. If power wiring is greater than the maximum distance shown, it is recommended that a service feeder be installed. When large gauge wire is used, a separate junction box must be installed for the operator connection. The wire table is based on stranded copper wire. Wire run calculations are based on a 110 VAC power source with a 3% voltage drop on the power line, plus an additional 10% reduction in distance to allow for other losses in the system.

Table 1 - MAXIMUM RUN (FT) PER WIRE GAUGE

110V AWG	14	12	10	8	6	4
MAX RUN (ft)	180	280	460	700	1150	1800

The gate operator system should be grounded through the earth ground in the AC mains wiring system (GREEN WIRE). This ground connection will prevent dangerous currents from appearing on the metal control box, the actuator, or the gate itself.

DO NOT WIRE AC MAINS POWER TO THE METAL CONTROL BOX WITHOUT AN EARTH GROUND CONNECTION!

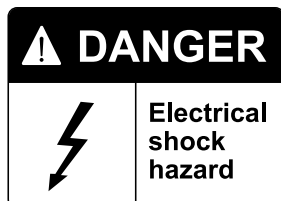

22 - SOLAR PANEL CHART

This Nice Operator is 12 Volt DC (Direct Current) powered. A 12 Volt sealed battery (33 ampere hour minimum for AC charged systems, 70 ampere hour minimum for solar charged systems) with connecting posts located on the top is recommended.

The following table should be used as a guide for capacity of operation of operators only, additional options and accessories may reduce the daily usage.

Please note that the charge capability of solar panels will vary with different geographical locations.

Daily cycles	1-10	1-20	1-40	1-60	1-80	80+
5 watt solar panel	*					
10 watt solar panel		*				
20 watt solar panel (requires regulator)			*			
30 watt solar panel (requires regulator)				*		
40 watt solar panel (requires regulator)					*	
1.5 amp battery charger					*	
10 amp battery charger						*
Note: Double the amount of solar wattage for dual gate operators						

Nice operators with the 1050 board that are used in solar applications need to be put into "Standby" mode.

To do this, press:

Function → scroll to #8 "Standby" → OK → Select desired amount of time before system enters, "Standby Mode" → OK

Once this is done, the operator will enter a Standby mode after the set time when the operator is not moving or in the auto-close countdown.

Things to note in Standby:

1. Display will be off and only a "heartbeat" will be present at the LED OK
2. Voltage at terminal #20 (24 volts) and terminal #38 (12 volts) will turn off - **DO NOT POWER ENTRY OR EXIT DEVICES HERE**
3. BlueBus function disabled until board "wakes"
4. Master/Slave syncing is non functional (used for commercial operators only)

Connection of the solar panel(s) may be made at the top left corner of the board at "Solar P" (regulated charging to the "Battery" via the controller in the board) – note that the maximum output of the regulator in the 1050 board is 1.5A. If the installation requires larger than a 30W solar panel – an off-board regulator should be used and connected directly to the battery.

23 - EXAMPLE WIRING CONNECTIONS

23.1 - Fire Dept. Connection

32 FIRE
33 GND

Dry contact input for a fire department control switch. Normally Open (NO) contact must be shorted to ground through a switch to open the gate. The FAIL SAFE connector which is shorted at the factory with a jumper (Normally Closed NC), may be wired in parallel with the Fire input to release the motor in the event of an emergency entry by the fire department during a power failure.

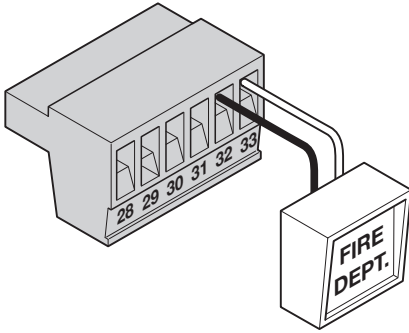

Figure - FIRE DEPT. INPUT

23.2 - Magnetic Lock Connection

7 NC
8 Com (Common)
9 NO
10 GND
11 V+ (Voltage is determined by incoming power supply)

This connection is used to install the magnetic lock. In this instance a gate can be locked magnetically to prevent a forced opening. Consult lock manual for specifics on installation and wiring

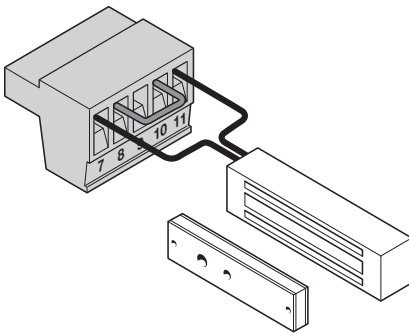

Figure - MAGNETIC LOCK WIRING (EXAMPLE)

23.3 - Guard Station

34 OPEN
35 STOP
36 CLOSE
37 GND

With the Guard Station switches installed, the user can operate the gate by pushing the respective buttons for the command that is desired. Gate Open and Close are controlled by NORMALLY OPEN (NO) and Stop is controlled by NORMALLY CLOSED (NC) momentary switches.

NOTE: If the guard station inputs are not used STOP (35) and GND (37) need to be tied together

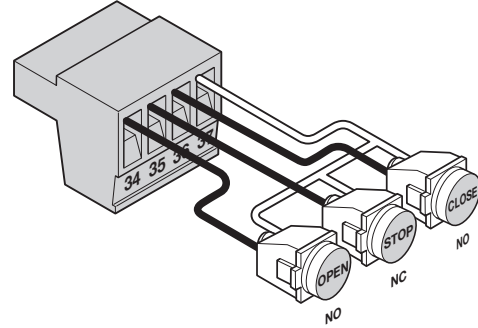

Figure - GUARD STATION INPUTS

23.4 - Exit and Edge Inputs Wiring Diagram

28 EDGE
29 GND
30 EXIT
31 GND

The EDGE input may be configured as a monitored ANALOG input, or DIGITAL (NC or NO) input. The EDGE sensor input is intended for ANSI/UL 325 listed gate edge sensors to protect against entrapment and hazardous pinch points along the moving edge of the closing gate. The EXIT sensor input is provided to activate to open the gate, or re-open a closing gate, upon sensing an exiting vehicle.

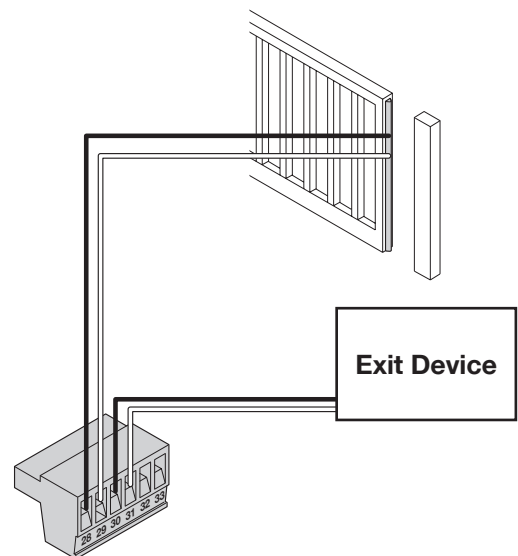

Figure - EXIT AND EDGE INPUTS

23 - EXAMPLE WIRING CONNECTIONS (CONT.)

23.5 - Radio Receiver Connection (Third Party)

38 12V
39 OPEN
40 CLOSE
41 GND

The customer supplied radio receiver allows the gate operator to be operated via remote, such as wireless key-card readers or user remote controls.

Connecting the Open (39) and Close (40) pins together with the relay of a receiver enables step by step gate control. This configuration allows a single button to control the gate in the following sequence:

Press - Gate Open
Press - Gate Stop
Press - Gate Close
Press - Gate Stop

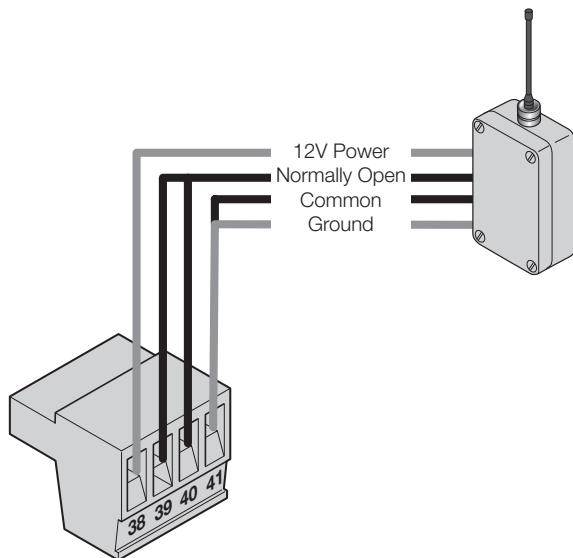

Figure - RADIO RECEIVER

23.6 - Optional Power Output

10 GND
11 V+

When the control board is in standby mode, power is still present at terminals 10 and 11. If standby mode is to be used (especially in a solar application) You may use the terminals 10 and 11 to provide power to accessories. Please note that the output voltage of terminal 11 is the same as the highest incoming voltage (on battery OR Main DC Power) to the control board.

For example:

If you are using a 12VDC battery to power to the control board connected to the Battery input, and the voltage of the battery is 13.5VDC - terminal 11 will have a 13.5VDC output.

If you are using a power supply input of 32VDC to the control board connected to the Main Power input - terminal 11 will have a 32VDC output.

If you are using a power supply connected to Main Power (at 32VDC) and also using a battery connected to the Battery input (at 13.5VDC) - terminal 11 will have an output of 32VDC.

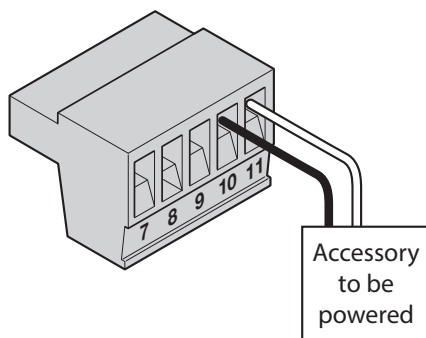

24 - INSPECTION AND OPERATION

Proper inspection of all equipment is required to ensure continuous functionality, safety and to ensure reliable operation in all weather conditions. Inspect electrical assemblies and wiring installations for damage, general condition, and proper functioning to ensure the continued satisfactory operation of the gate operating system. Adjust, repair, overhaul, and test electrical equipment and systems in accordance with the recommendations and procedures in the gate operator system and/or component manufacturer's maintenance instructions.

Replace components of the gate operating system that are damaged or defective with identical parts, with manufacturer's approved equipment, or its equivalent to the original in operating characteristics, mechanical strength, and environmental specifications. A partial list of suggested problems to look for and checks to be performed are listed below:

- 24.1 Damaged, discolored, or overheated equipment, connections, wiring, bearing caps and installations.
- 24.2 Excessive heat or discoloration at high current carrying connections. (look for bluing or heat affected metal).
- 24.3 Misalignment of electrically driven equipment. (Causes strain on pulley assemblies and bearings).
- 24.4 Poor electrical bonding (broken, disconnected or corroded bonding strap) and grounding, including evidence of corrosion.
- 24.5 Dirty equipment and connections. Clean equipment and connections.
- 24.6 Improper, broken, inadequately supported equipment, wiring and conduit, loose connections of terminals, and loose ferrules.
- 24.7 Poor mechanical or weld joints. Broken welds.
- 24.8 Condition of circuit breaker and fuses. Ensure that they are of the correct type and amperage.
- 24.9 Insufficient clearance between exposed current carrying parts and ground or poor insulation of exposed terminals. All exposed connections must be covered (prevent arcing between exposed parts, and electrical shock).
- 24.10 Broken or missing wire, connectors, etc.
- 24.11 Operational check of electrically operated equipment such as motors, inverters, generators, batteries, lights, protective devices, etc. Ensure proper functionality of all systems during inspections.
- 24.12 Ensure safety placards and warning signs are present as specified within this document. Ensure proper functionality of all safety devices as specified. Non-functioning or malfunctioning safety devices should be replaced immediately.

25 - GENERAL LAYOUT AND SAFETY ACCESS

25.1 -Swing Gate

Possible Entrapment Zones - Typical Installation Diagram Utilizing Loop Sensors and Photocells

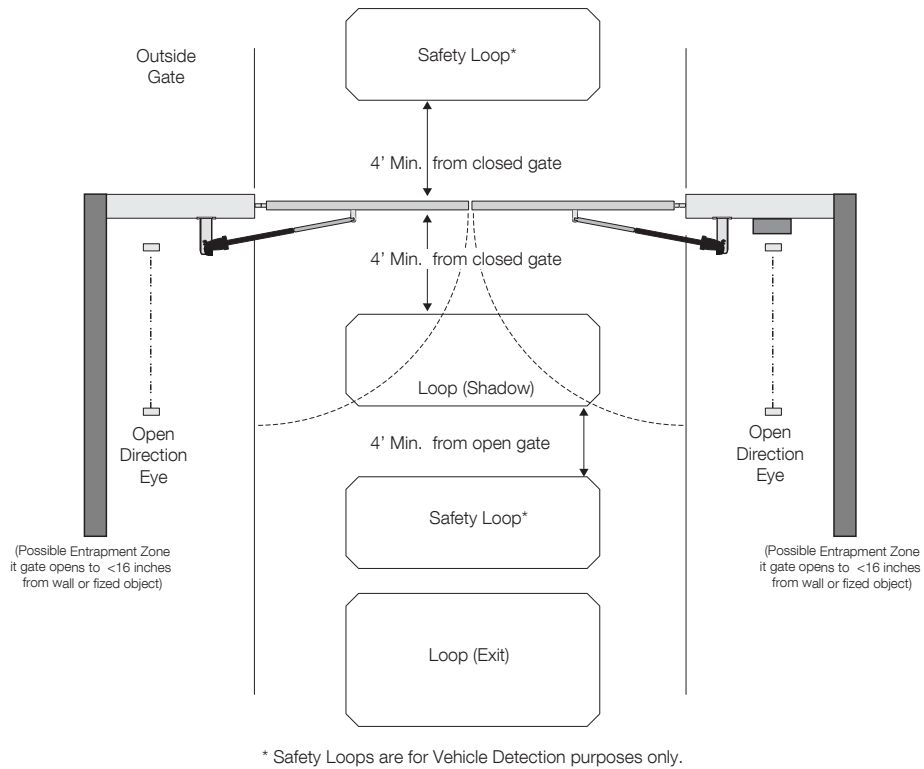

Figure - LAYOUT FOR IN-GROUND LOOPS

Possible Entrapment Zones - Typical Installation Diagram Utilizing Photocells

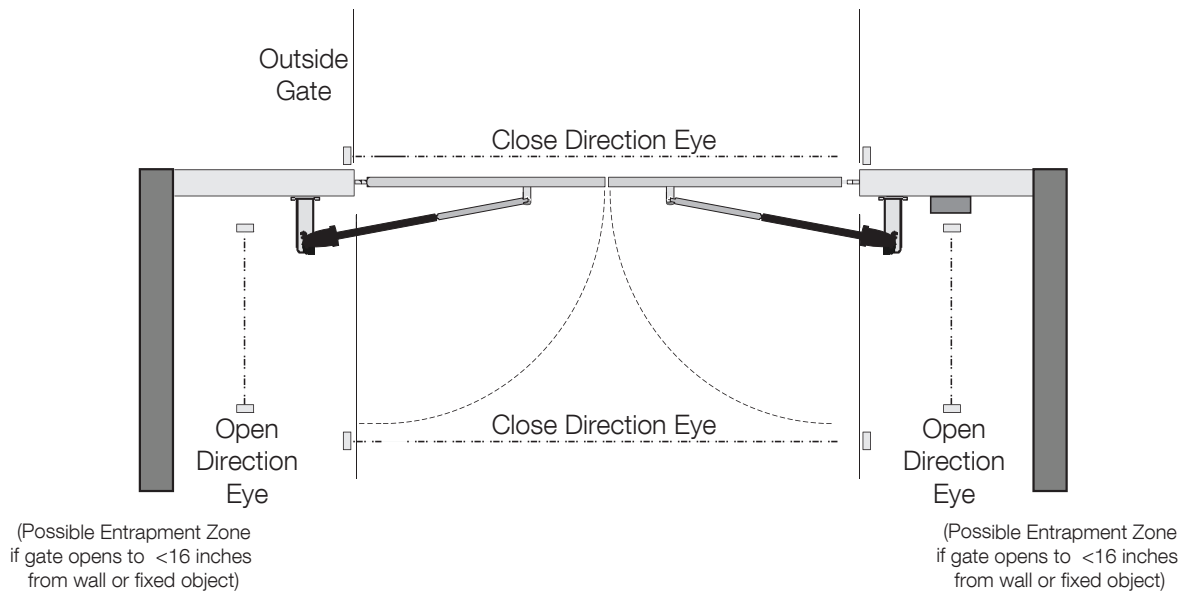

Figure - LAYOUT FOR PHOTOCELLS

EXTERNAL ENTRAPMENT PROTECTION

Non-contact and contact sensors must be installed individually or in combination with each other to provide complete external entrapment protection.

Care should be exercised to reduce the risk of nuisance tripping, such as when a vehicle trips the sensor while the gate is still moving, and one or more non-contact sensors shall be located where the risk of entrapment or obstruction exists, such as the perimeter reachable by a moving gate or barrier.

A hardwired contact sensor shall be located and its wiring arranged so that the communication between the sensor and the gate operator is not subjected to mechanical damage.

A wireless contact sensor such as one that transmits radio frequency (RF) signals to the gate operator for entrapment protection functions shall be located where the transmission of the signals are not obstructed or impeded by building structures, natural landscaping or similar obstruction.

DURING INSTALLATION

- DISCONNECT POWER at the control panel before making any electric service power connection.
- Be aware of all moving parts and avoid close proximity to any pinch points.
- Know how to operate the manual release.
- Adjust the unit to use the minimum force required to operate the gate smoothly even during mid-travel reversing.
- Place controls a minimum of 8 feet away from the gate so that the user can see the gate and operate controls but cannot touch the gate or gate operator while operating the controls.
- Warning signs must be placed on each side of the gate or in high-visibility areas to alert of automatic gate operations.

26.1 - Monitored Safety Device

BlueBus photo-eyes:

The EPMOB photocell is a thru-beam device - consisting of a transmitter (TX) and a receiver (RX) that connects via two (2) wires. Polarity of the wiring is not important. EPMOBs may be wired in parallel to one another or directly to the board - it is not necessary to make a "home run" to the board with each EPMOB. Multiple sets of EPMOBs may be used, however each PAIR must be set to an exclusive address by setting the jumpers in the units. What this means, is that each pair of eyes must have their jumpers set to match each other - but every pair must be set differently from the other pairs. The address jumpers also determine the functionality of each set of eyes: Open direction or Close direction, etc. (see Table 1).

1. Mount the transmitter and receiver appropriately to a rigid mounting surface. Eyes should be placed appropriately to protect areas of entrapment according to UL325 guidelines.
2. Set the jumpers in each pair of eyes to match each other. Ensure that each pair of eyes are set differently. Use the table below to find the setting of the jumpers that corresponds to the functionality desired from each pair of eyes.
3. Connect the EPMOBs to the Bluebus connector of the circuit board. Polarity of the wiring is not important. Eyes may be connected in parallel to one another - or directly to the board.
4. LEARN the Bluebus port.
On a 1050 board - Press Functions (1. Learn) - Press "OK" (Learn Bluebus) - Press "OK". Allow the board to scan the Bluebus Port.
When complete - test the functionality of each set of eyes.
5. Fine tune the alignment of each pair of eyes. The more slowly the lights flash on the units - the better they are aligned.

Close Direction A/B: Resets timer to close in open position, reverses gate if closing, no effect if gate is closed or during opening cycling. Typically used when the photo eyes are on the outside of the property (gates opening inward).

Close Direction 2 A/B: Resets timer to close in open position, reverses gate if closing AFTER obstruction is cleared, pauses the gate on opening cycle - opening resumes after obstruction clears. Typically used when the photo eyes are on the inside of the property (gates opening inward).

Open Direction A/B: Delays gate opening from closed position. Stops and reverses gate back closed on open cycle. Typically used to protect an entrapment point when the gates are opening.

Table 1	
Photocell	Jumpers
CLOSE DIRECTION A	
CLOSE DIRECTION B	
CLOSE DIRECTION 2A	
CLOSE DIRECTION 2B	
OPEN DIRECTION A	
OPEN DIRECTION B	
NOT USED	

27 - IRB-RET Wiring Diagram

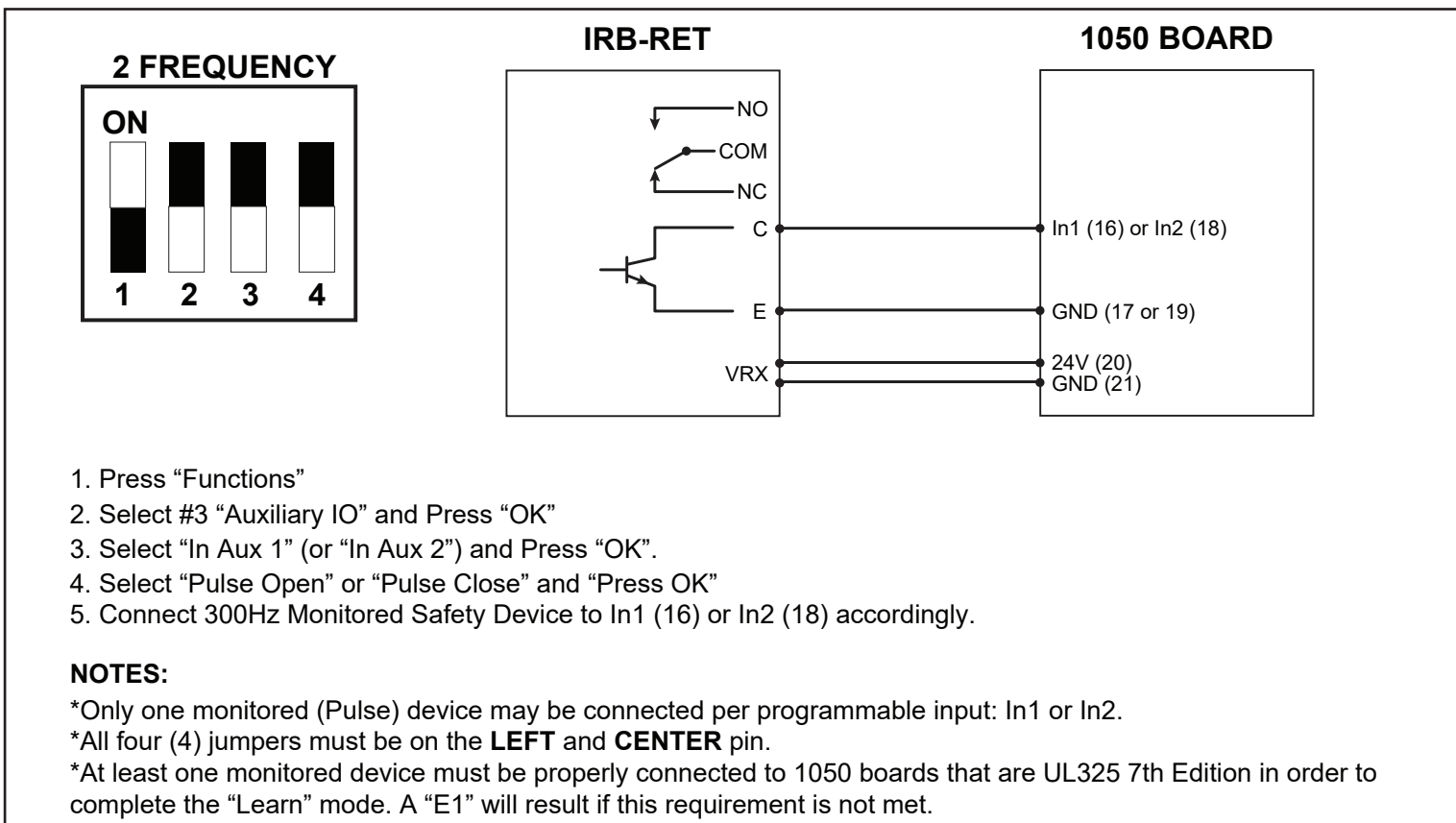

28 - GEM-103 Wiring Diagram

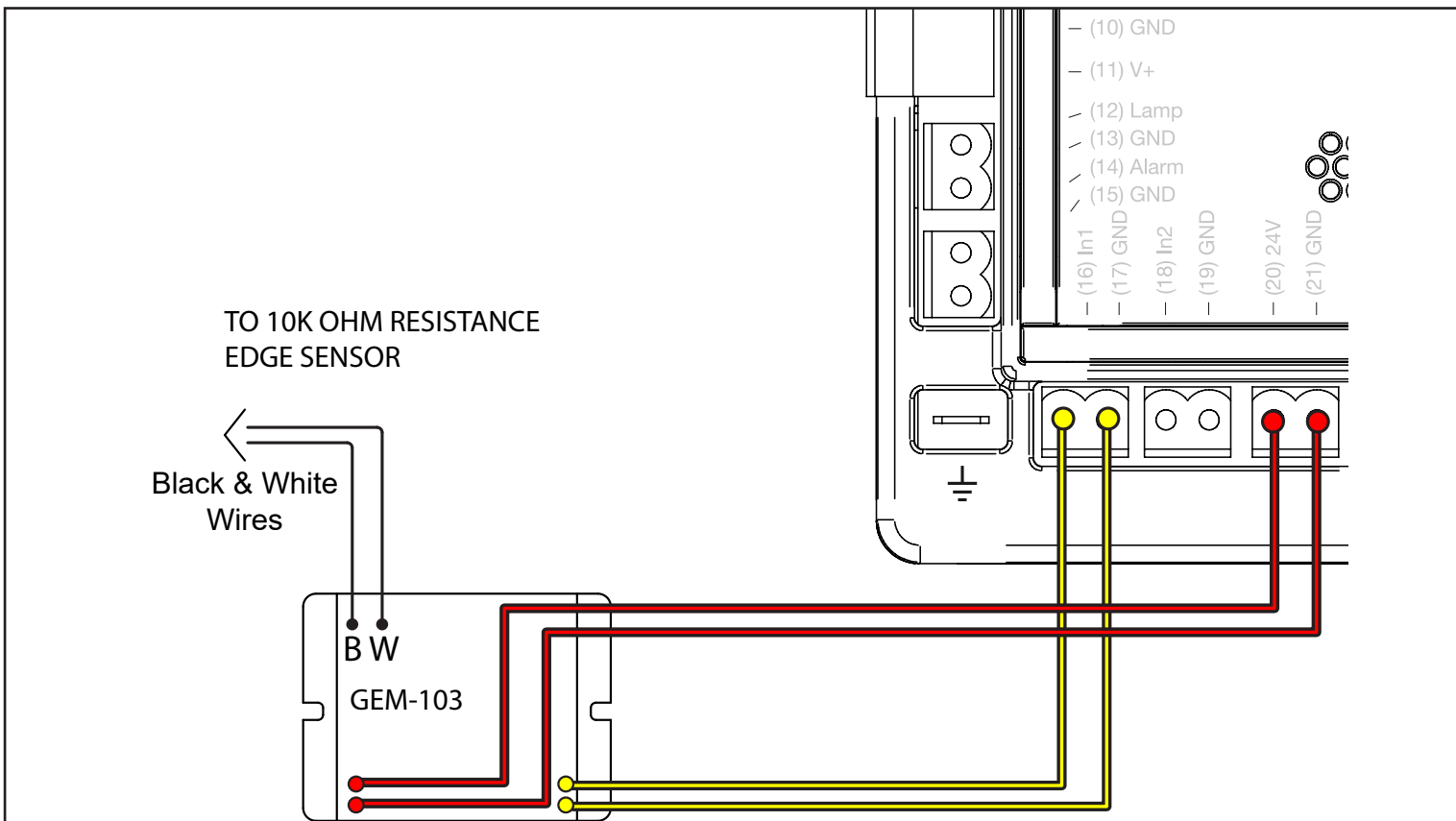

EMX WEL-200 Wireless Edge Receiver

Dip Switch Settings determine which relay activates when the associated edge is tripped.

See WEL-200 manual for instructions for programming receiver/transmitter pairs.

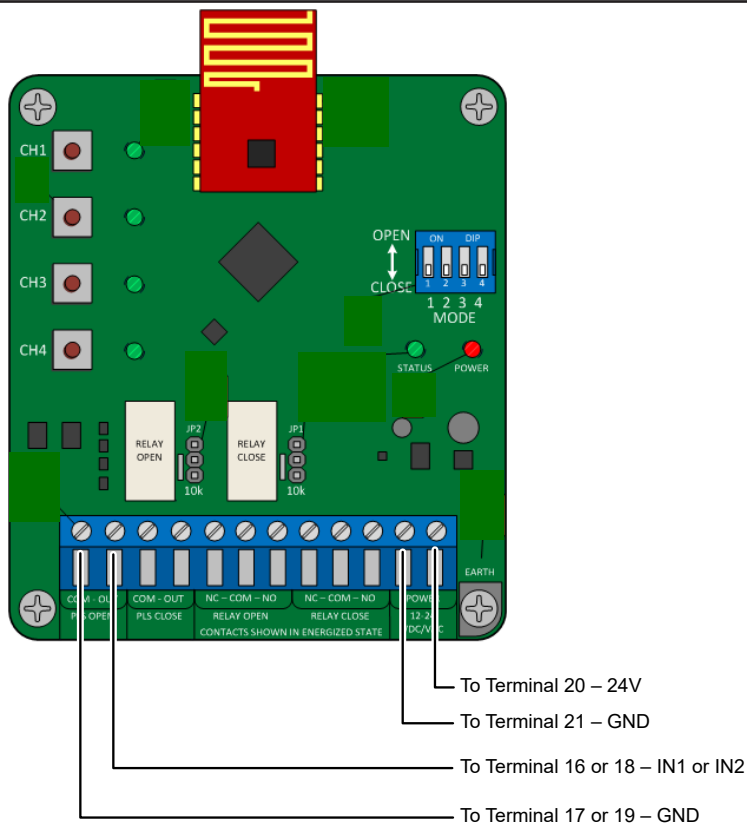

WARNING

AVERTISSEMENT

Moving Gate can cause Serious Injury or Death.

Persons are to keep clear! The gate is able to be moved without prior warning.
Do not allow children to operate gate or play in gate area.
This entrance is for vehicles only. Pedestrians must use separate entrance.

Le portail en mouvement peut causer des blessures graves ou la mort.

Les personnes ne doivent pas s'approcher!
Le portail est capable d'être bougé sans avertissement préalable.
Ne pas laisser les enfants utiliser le portail ou jouer dans le domaine du portail.
Cette entrée est réservée aux véhicules.
Les piétons devront utiliser une entrée séparée.

30 - BOARD NOMENCLATURE

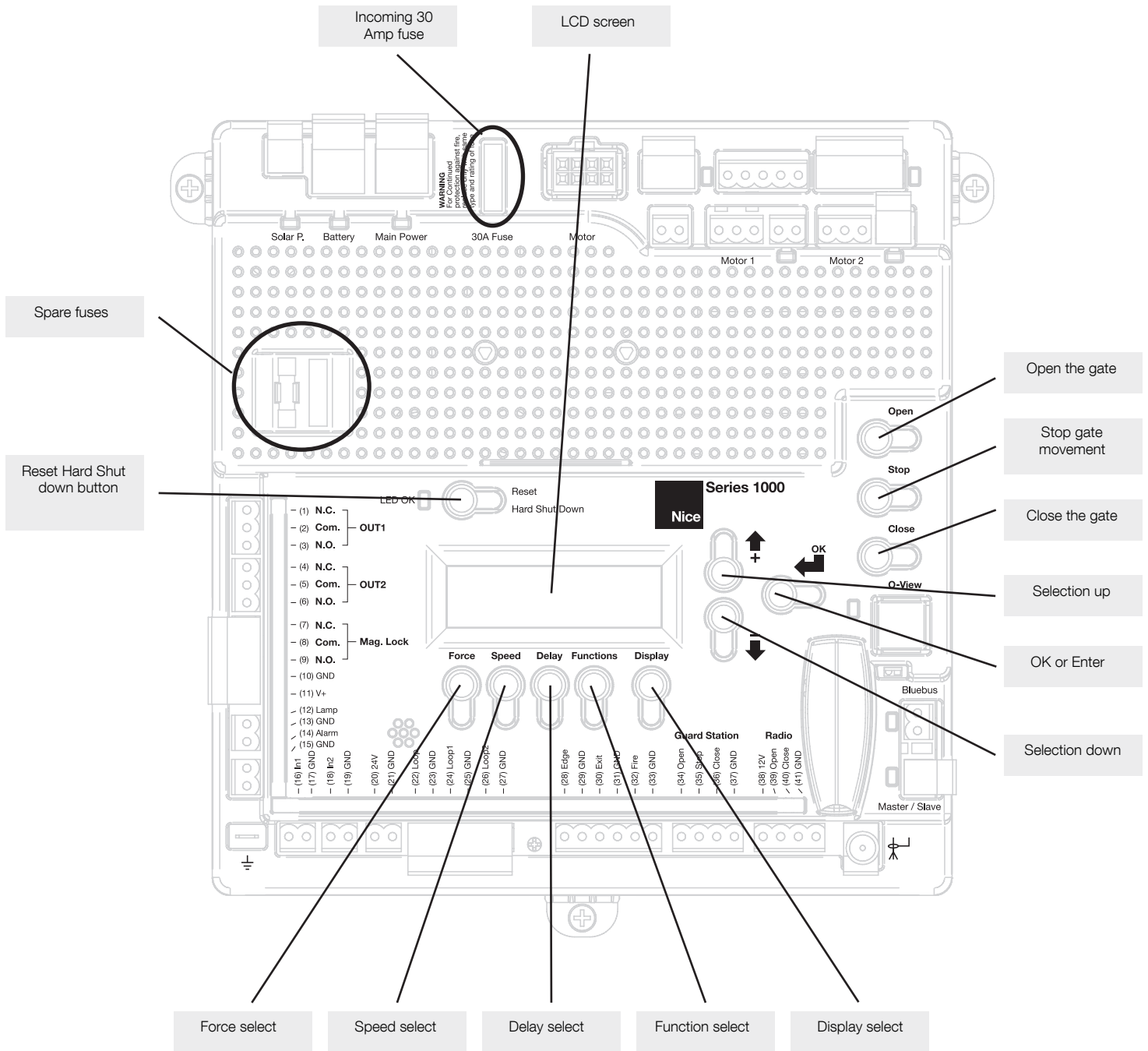

Figure - GENERAL BOARD OVERVIEW

THE PROGRAMMING BUTTONS INDICATED IN THE ABOVE REFERENCE SHOULD BE USED ONLY AFTER UNDERSTANDING THE MANUAL AND ITS RELATION TO THE PROGRAMMING SEQUENCES SHOWN ON THE FOLLOWING PAGES. CARE SHOULD BE TAKEN WHENEVER CHANGES ARE IMPLEMENTED TO ENSURE PROPER FUNCTIONALITY AND SAFETY.

31 - PROGRAMMING BUTTONS

31.1 - Force

1. Static: Set sensitivity to constant force on a scale of 1 to 10 (1 being the most sensitive).

2. Dynamic: Set sensitivity of sudden impact force to the moving gate on a scale of 1 to 10 (1 being most sensitive).

3. ESC: Exit the FORCE menu.

31.2 - Speed

1. Max: Sets the limit of maximum allowed gate speed on a scale of 20% to 100% (20% being the lowest setting).

2. Standard: Sets the limit of the gate speed during normal movement (not soft start/stop) on a scale of 20% to MAX (20% being the lowest setting).

3. Low: Sets the limit of the gate speed while in LEARNING mode and when moving in SLOW, on a scale of 20% to 100% (20% being the lowest setting).

4. Slowdown: Set gate speed when going into approaching the open or close limits on a scale of 20% to 100% (20% being the lowest setting).

- Acceleration

5. Max: Sets the limit of gate acceleration when reversing the gate after an obstacle has been detected by the UL/Edge or current sense feature (Force). Settings from 3 to 10, with 10 being the highest rate of gate acceleration. *

6. Standard: Sets the limit of the gate acceleration in normal operation. Settings from 1 to MAX, with MAX being the highest rate of gate acceleration. * TO PREVENT DAMAGE TO THE GATE OR THE CONTROLLER USE LOWER ACCELERATION SETTINGS FOR HEAVIER GATES.

7. ESC: Exit the SPEED menu.

31.4 - Delay

1. Auto Close: Sets the timeout before the gate closes automatically from the fully open position. Settings from 0 (off) to 90 seconds. Setting this to 0 will disable the auto close timer.

2. Slave: Sets the delay for opening the slave gate leaf in a Master/Slave (Motor 1 and Motor 2 operation), (dual gate) system. Settings from 0 to 5 seconds with a step of 0.5 seconds.

3. Lamp/Strobe: Sets the amount of time the Lamp accessory output is activated prior to gate movement. Settings from 0 to 5 seconds with a step of 0.5 seconds.

4. Lock: Sets the amount of time the Magnetic Lock accessory output is activated to disable the lock when opening the gate. Settings from 0 to 5 seconds with a step of 0.5 seconds.

5. Run Time: Sets the maximum run time for the gate. Used in case the gate doesn't reach its limits. Settings from 15 to 120 seconds with a step of 1 second.

6. ESC: Exit the DELAY menu.

31.5 - Function

1. Learn: Puts the gate operator into learning mode for a Swing or Slide gate, and Blue BUS peripherals. Learning mode for a Swing or Slide style gate involves selecting the gate type (Light, Average, Heavy), then fully opening and closing the gate to sense the limits. Selecting the gate type selects pre-calculated values for the FORCE, SPEED, and ACCELERATION settings. Learning the Blue BUS peripherals enables the gate operator to discover and integrate accessory devices like Blue BUS access control and safety devices.

2. Positions: Configures the points in the gate open, close, and partial cycles at which deceleration occurs.

- Slow Down – Open: Sets the point in the % of gate opening when the gate begins deceleration to the fully open position.
- Slow Down – Close: Sets the % of gate opening when the gate begins deceleration to the fully close position.
- Partial: Sets the point in the % of gate opening when the gate begins when given a PARTIAL command.

3. Auxiliary Inputs: Auxiliary inputs IN1(16) and IN2 (18) can be programmed with one of the following options:

- No program No Function used
- OPEN the Gate
- CLOSE the Gate
- STEP Cycling Step (Open-Stop-Close-Stop)
- PARTIAL opening
- PARTIAL 1 Partial Opening 1 (open one leaf in dual gate applications)
- STOP the gate and Auto-closing
- HOLD TO OPEN Input must be maintain active for Opening
- HOLD TO CLOSE Input must be maintain active for Closing
- FIRE Reset Hard Shut Down and Open the Gate
- TIMER 1 Start Count Down TIMER1
- TIMER 2 Start Count Down TIMER2
- PHOTO Photocell PHOTO input: reverse to opening when closing
- PHOTO1 Photocell PHOTO1 input: Stop Gate when activated
- PHOTO2 Photocell PHOTO2 input: reverse to closing when opening
- SHADOW Loop input: prevent closing gate when completely open
- LOCK system from other command (only STEP H overrides the lock)
- UNLOCK Unlock the system if locked
- OPEN and LOCK Open the Gate and inhibit further commands (except STEP H)
- CLOSE and LOCK Close the Gate and inhibit further commands (except STEP H)
- OPEN and UNLOCK Open the Gate and un-inhibit further commands
- CLOSE and UNLOCK Close the Gate and un-inhibit further commands
- STEP H Command high priority Step cycling (open-stop-close-stop)
- Open 1 - Reopens a gate that has drifted off its open limit.
- Open Pulse - Connect a monitored external entrapment sensor with a pulse output that protects the open direction of travel.
- Close Pulse - Connect a monitored external entrapment sensor with a pulse output that protects the close direction of travel.

Auxiliary Outputs: Auxiliary outputs OUT1 (1,2,3,) and OUT2 (4,5,6,) can be programmed with one of the following options:

- NO PROGRAM Output not used
- OPEN Output is activated when Gate is open
- CLOSE Output is activated when Gate is closed
- MOVING Output is activated when Gate is moving
- TIMER 1 Output is activated when TIMER1 is counting down
- TIMER 2 Output is activated when TIMER2 is counting down

4. Radio Channel: For the Plug-in On board Receiver, 15 radio channels may be programmed with one of the following options:

- NO PROGRAM
- OPEN (Default CH. 2)
- CLOSE
- STEP (Default CH. 1)
- PARTIAL
- PARTIAL 1
- STOP
- HOLD TO OPEN
- HOLD TO CLOSE
- TIMER 1
- TIMER 2
- PHOTO
- LOCK
- UNLOCK
- OPEN and LOCK
- CLOSE and LOCK
- OPEN and UNLOCK
- CLOSE and UNLOCK
- STEP H
- TOGGLE & LATCH

5. Timers: Set time for count down timers Timer 1 and Timer 2. Settings between 1 second and 9 hours in 1 second increments.

31 - PROGRAMMING BUTTONS (CONT.)

6. Events: Up to 8 weekly events (EV1 through EV8) can be programmed and stored. Each event can be programmed to trigger at a specific time and can be assigned to any combination of days of the week (Monday through Sunday). Events that are already programmed into the system may be suspended temporarily, or removed permanently from memory. The following actions can be assigned to events:

- No program
- Open
- Close
- Partial
- Partial 1
- AxOut1 On
- AxOut1 Off
- AxOut2 On
- AxOut2 Off
- Open and Lock
- Close and Lock
- Open and Unlock
- Close and Unlock
- Timer 1
- Timer 2

To program weekly events EV1 through EV8, perform the following steps:

1. Press FUNCTION -> Events.
2. Press and hold OK to display EV1 (display will blink "EV1").
3. Press UP or DOWN to toggle between events, then press OK to make a selection. The display changes to hours.
4. Press UP or DOWN to toggle between hours, then press OK to make a selection. The display changes to minutes.
5. Press UP or DOWN to toggle between minutes, then press OK to make a selection. The display changes to individual days of the week.
6. Press UP or DOWN to toggle between days of the week. Press OK to toggle between ON and OFF for each day of the week. Continue toggling through the days of the week until ESC is displayed. Press OK to advance to the next event.
7. Repeat step 2 through 6 for event EV2 through EV8.

To temporarily suspend one or more weekly events (EV1 through EV8), perform the following steps:

1. Press FUNCTION -> Events.
2. Press OK quickly to display EV1 active days.
3. Press OK quickly again to display "Suspend". Event EV1 is now suspended and will not run until re-enabled.
4. Press UP or DOWN to toggle through the events EV1 – EV8 and repeat steps 2 through 3 to suspend or enable other weekly events.

7. Charger: A battery charger is built-in with the Control board for use with a backup battery. The charger may be manually programmed for customized charge settings or set to "Auto" to provide a battery charging profile that automatically compensates for temperature and current during the charging process. The following parameters are available for programming the battery charger:

- Charger On/Off
- Select Max current for charging (from 0.1A to 1.5A step 0.05A)
- Cycling Time (1 second off charging every cycling time)
- Auto (best charge considering temperature)

Note: All parameters **MUST** be confirmed or charging systems will default to **OFF**.

8. Standby: Programs the timeout for the gate operator to go into low power standby mode. Low power standby is Settings from 5 to 120 seconds, or may be disabled with "OFF". During low power standby there is no data displayed on the gate operator LCD and it consumes a minimum amount of power to extend the life of the backup battery. All the outputs are switched off and the LED OK blinks to show this standby status of the system.

Note: Power outputs at #20 and #38 will also turn **OFF** when board enters Standby mode.

9. Advance Settings: The following settings are available for customizing the gate operator as required by the customer's installation requirements:

- Set Language (English Spanish French)
- Set clock 12H/24H
- Set LCD Contrast
- Direction Motor (Changes main motor direction) (Can only be performed in learn mode)
- Auto Close Option (Allows auto close timer to close from any open position)
- Exit Option (Disables free exit input when partially open)
- Set Anti-tailgate (Closes gate immediately after vehicle has cleared safety sensors)
- Select inputs LOOP or PHOTO
- Select UL/EDGE input type (NO, ANALOG OPEN, ANALOG CLOSE, ANALOG BOTH)

Note: When set to ANALOG OPEN, CLOSE, or BOTH, this input must have an 8.2k-10k Ohm terminated external entrapment sensor installed. ANALOG BOTH is only available for Swing Gates.

Note: When set to ANALOG, this will be a monitored input and will satisfy one of the required sensors for monitored entrapment.

- Select Master / Slave Motor1 or Motor2
- Activate link for remote Master/Slave (Enables control of an additional gate operator board)
- Power Fail Open (Opens gate automatically on batter backup power if main AC power input loss is detected)
- Motor 12V (Forces motor control voltage to +12VDC even if the supply voltage varies from +9.5VDC up to +35VDC)
- Set Virtual Encoder (Used for motors without built-in encoders)

10. Default: This setting gives the installer/user the option of returning some or all settings of the gate operator to the original factory settings:

- System settings
- Radio Channel settings
- Event settings
- Charger settings

11. Gate Sync: This setting turns ON/OFF the gate synchronization on dual gate systems.

Note: The operator with the shortest run time should be connected to the Motor1 output of the board. When turned ON - this feature will slow Motor1 down to match the run time of Motor2.

12. ESC: Exit the FUNCTION menu.

31.6 - Display

1. ESC: Exit the DISPLAY menu.

2. Info: Displays the manufacturer name, product name/model, software versions, and serial number.

3. Clock: Displays the calendar date and time in the real time clock. Pressing and holding the "OK" button for 5 seconds enables the date and time settings to be updated manually.

4. Main Volt: Displays the gate operator main control voltage in volts DC.

5. Battery Volt: Displays the gate operator backup battery voltage in volts DC.

6. Sun Volt: Displays the solar panel input voltage in volts DC.

7. Motor Volt: Displays the voltage at the motor in volts DC.

8. Service: The following information is recorded and viewable about the operating history of the gate:

- Total: Displays the total number of open-close cycles (non- Settings).
- Partial: Display the total number of partial cycles. Reset by pressing the "OK" button for several seconds.
- Maint. Display the number of cycles before service is required. Settings from 1000 to 50000 cycles in increments of 1000 cycles.

9. Motor: Displays the Motor position, voltage, and current.

10. Motor 1: Displays the Motor1 position, voltage, and current.

11. Motor 2: Displays the Motor2 position, voltage, and current.

12. Charger: Displays the battery charger voltage and current.

13. Diagnostic: Factory Use Only.

14. Last Reset: Factory Use Only.

32 - EMERGENCY VEHICLE ACCESS

- 32.1** The automatic vehicular gate system must be designed to allow access to emergency vehicles under different operating conditions.
- 32.2** During normal powered operation, emergency vehicles access the gate by use of the emergency vehicle access device installed on your gate system. The type of device that is used in your community is dependent on your city codes. These devices may include (but are not limited to) Fire Department lock boxes, Click-2-Enter radio receivers, strobe light sensors, siren sensors, etc.
- 32.3** Check with your installer to determine if your gate system is equipped with a back-up power system. In the event of a primary (AC) power failure and a back-up system (DC) power failure (low charged or dead batteries for example), the system must have a release system to allow the gate to be manually operated. The release device must be accessible from either side of the gate and must be present so that emergency personnel can gain access through the gate under this condition.
- 32.4** If applicable, this system is equipped with a manual release system that will allow the gate to be pushed open in the event of a power outage or equipment failure.
- 32.5** NOTE: Never attempt to manually push open any gate with an operator attached to it until you have verified that power to the operator has been shut-off.
- 32.6** The automatic vehicular gate system must be designed to allow access to emergency vehicles under different operating conditions.
- 32.7** In the event of a power failure, the emergency vehicle access device may not be functional because the gate operator is not powered. NOTE: DC powered back-up systems are optional and your gate system may or may not be equipped with one. Check with your installer to determine if your gate system is equipped with a back-up power system.
- 32.8** For manual fail-safe gate operation, turn power to the operator OFF. If a backup power system is in use, be sure that this power is turned OFF also or disconnected. Once power is OFF, the gate can be manually operated, by disconnecting the gate attachment bracket (816).

33 - GLOSSARY

LOCK - Ceases all operator function except HIGH PRIORITY inputs.

COMMERCIAL / GENERAL ACCESS VEHICULAR GATE OPERATOR-CLASS II - A vehicular gate operator (or system) intended for use in a commercial location or building such as a multi-family housing unit (five or more single family units), hotels, garages, retail store, or other building servicing the general public.

ENTRAPMENT - The condition when an object is caught or held in a position that increases the risk of injury.

FORCE STATIC - Constant load threshold for sensitivity setting.

FORCE DYNAMIC - Impact sensitivity setting.

GATE - A moving barrier such as a swinging, sliding, raising, lowering, or the like, barrier, that is a stand-alone passage barrier or is that portion of a wall or fence system that controls entrance and/or egress by persons or vehicles and completes the perimeter of a defined area.

(STEP H) HIGH PRIORITY - Step by step control.

INHERENT ENTRAPMENT SENSOR SYSTEM - An automatic sensor system which senses entrapment of a solid object and is incorporated as a permanent and integral part of the operator.

INDUSTRIAL / LIMITED ACCESS VEHICULAR GATE OPERATOR- CLASS III - A vehicular gate operator (or system) intended for use in an industrial location or building such as a factory or loading dock area or other locations not accessible by the general public.

RESTRICTED ACCESS VEHICULAR GATE OPERATOR-CLASS IV - A vehicular gate operator (or system) intended for use in a guarded industrial location or building such as an airport security area or other restricted access locations not servicing the general public, in which unauthorized access is prevented via supervision by security personnel.

RESIDENTIAL VEHICULAR GATE OPERATOR-CLASS I - A vehicular gate operator (or system) intended for use in a home of one-to four single family dwelling, or garage or parking area associated therewith.

STEP BY STEP - Command that opens-stops-closes-stops the gate with each press of the button.

SYSTEM - In the context of these requirements, a system refers to a group of interacting devices intended to perform a common function.

UNLOCK - Resumes normal operation after a blocked condition.

WIRED CONTROL - A control implemented in a form of fixed physical interconnections between the control, the associated devices, and an operator to perform predetermined functions in response to input signals.

WIRELESS CONTROL - A control implemented in means other than fixed physical interconnections (such as radio waves or infrared beams) between the control, the associated devices, and an operator to perform predetermined functions in response to input signals.

34 - MAINTENANCE SCHEDULE

Table 2

		COMPLETE	BASIC
Alarm	Activate the (inherent) reverse system by blocking the gate with a solid object. The gate should reverse momentarily then stop. Restart the gate and block again with a solid object. The gate should reverse momentarily, then stop, and go into hard shutdown with an alarm	●	●
Backup System	If operator is equipped with DC backup system, check to be sure the system opens the gate upon loss of AC power	●	●
Battery	If operator is equipped with DC backup system, check the batteries for any leakage or loose connections. Batteries should be replaced every two years	●	
Fire Dept	Check emergency vehicle access device for proper operation	●	●
Gate	Inspect for damage	●	
Reverse System	Check that the gate reverses on contact with an object in both the opening and closing cycles	●	●
Loop(s)	Check vehicular reverse and shadow loops for proper operation	●	●
Release	Check manual release for proper operation	●	
Complete	Overall Check: Complete check of gate and gate operating system	●	
Mounting Hardware	Check screws and nuts	●	

35 - TROUBLESHOOTING

Table 3

SYMPTOM(S)	POSSIBLE SOLUTION
Operator will not Power On. Power LED is OFF	Check that power to the circuit board is turned ON Check terminal block wiring for loose or broken wires If voltage measures OK, check the terminal block Check the fuses (may be both AC and DC fuses in installation)
Gate opens a short distance, then stops and reverses	Check the external entrapment sensors on the gate controller Adjust Force Settings
Gate opens but will not close	Check the input LEDs. Any ON will hold the gate open and indicates a problem with a keying device Check the external entrapment devices. Any activated devices will hold the gate open and indicates a possible problem with the device Check the loop detectors. Any activated loop detectors can hold the gate open and indicates a possible problem with the loop detector or ground loop
Battery backup system will not open gate upon AC power outage	Check if backup system is set to open gate automatically or requires an input to open Check the batteries for proper voltage. Replace if necessary
Hard Shutdown (2 back to back obstructions) LED blinking, Buzzer sounds for 5 minutes	Clear any obstructions from the path of the gate. Press RESET to clear (or hard reset button)
Gate opens by itself	Check accessory inputs and clear then as necessary

Table 4: 1050 Board Display Read Out and Troubleshooting

DISPLAY	REASON	POSSIBLE SOLUTION
Dynamic M1	Actuated connected to Motor 1 has a brief current spike and tripped Type A sensor.	Check for obstruction in gate path or degraded gate hardware.
Dynamic M2	Actuated connected to Motor 2 has a brief current spike and tripped Type A sensor.	Check for obstruction in gate path or degraded gate hardware.
Static M1	Actuated connected to Motor 1 has an extended current spike and tripped Type A sensor.	Check for obstruction in gate path or degraded gate hardware.
Static M2	Actuated connected to Motor 2 has an extended current spike and tripped Type A sensor.	Check for obstruction in gate path or degraded gate hardware.
Input UL/Edge	UL/Edge input is tripped while gate is running. Appears is IN1 or IN2 input is tripped if configured as a pulsed, external sensor input.	Ensure photo eyes are aligned, edges are not tripped, and all inputs are programmed correctly.
Input STOP!	STOP input is not connect to GND.	Ensure jumper wire is being used and check external stop button wiring.
Photo Test FAIL!	BlueBus monitored sensor check fails.	Verify photo eye is connected, aligned, and internal jumpers are set correctly.
Device Error	Position sensor is not being correctly detected by the board or if there is an active input on the board preventing the learn process.	Ensure Motor 1 and Motor 2 position sensors are connected correctly for the type of actuator being used. Also make sure there are no active inputs.
Gate Opened	Appears during Learn Mode if Open Limit is active.	Change gate to mid-travel and restart the learn process.
BlueBus or Input - Activated	Appears when active BlueBus or other external entrapment sensor input is preventing gate motion.	Ensure all sensors are connected correctly and properly aligned. Ensure all inputs are programmed correctly.
Hard Shut Down	Appears when Dynamic and/or Static sensors have two consecutive trips.	Press the Reset/Hard Shut Down button to clear the trip and reenable gate operation.
Overload	Appears when Motor 1 or Motor 2 over-current.	Ensure motors are connected properly and there is no obstruction to gate movement.
Slide Requires - Min 2 Sensors	Appears when there are not at least two external entrapment sensors programmed and installed on a Slide Gate: 1. Open direction 2. Close direction.	Ensure all sensors are connected correctly and functional. Does not appear on Swing gates.
1 Open & 1 Cls - Sensor Required	Appears when Slide Gate operator does not at have at least one external entrapment sensor programmed and installed in each direction.	Ensure all sensors are connected correctly and functional. Does not appear on Swing gates.
Min. 1 Sensor - For Swing Gate!	Appears when Swing gate operator does not have at least one entrapment sensor programmed and installed for both open and close direction for travel.	Install minimum number of sensors. Does not appear on Slide Gates
BlueBus Error!	Appears when previously learned numbers and type of BlueBus sensors change.	Correct wiring/number of sensors and redo the learn procedure for the operator.
Scanning BluBus - Prs Disp to Cncl	Appears when initial BlueBus learn procedure is in process.	Pressing the Display button will postpone the scan and remain in Learn Mode. Pressing and holding the open or close buttons will move the gate in the desired direction.

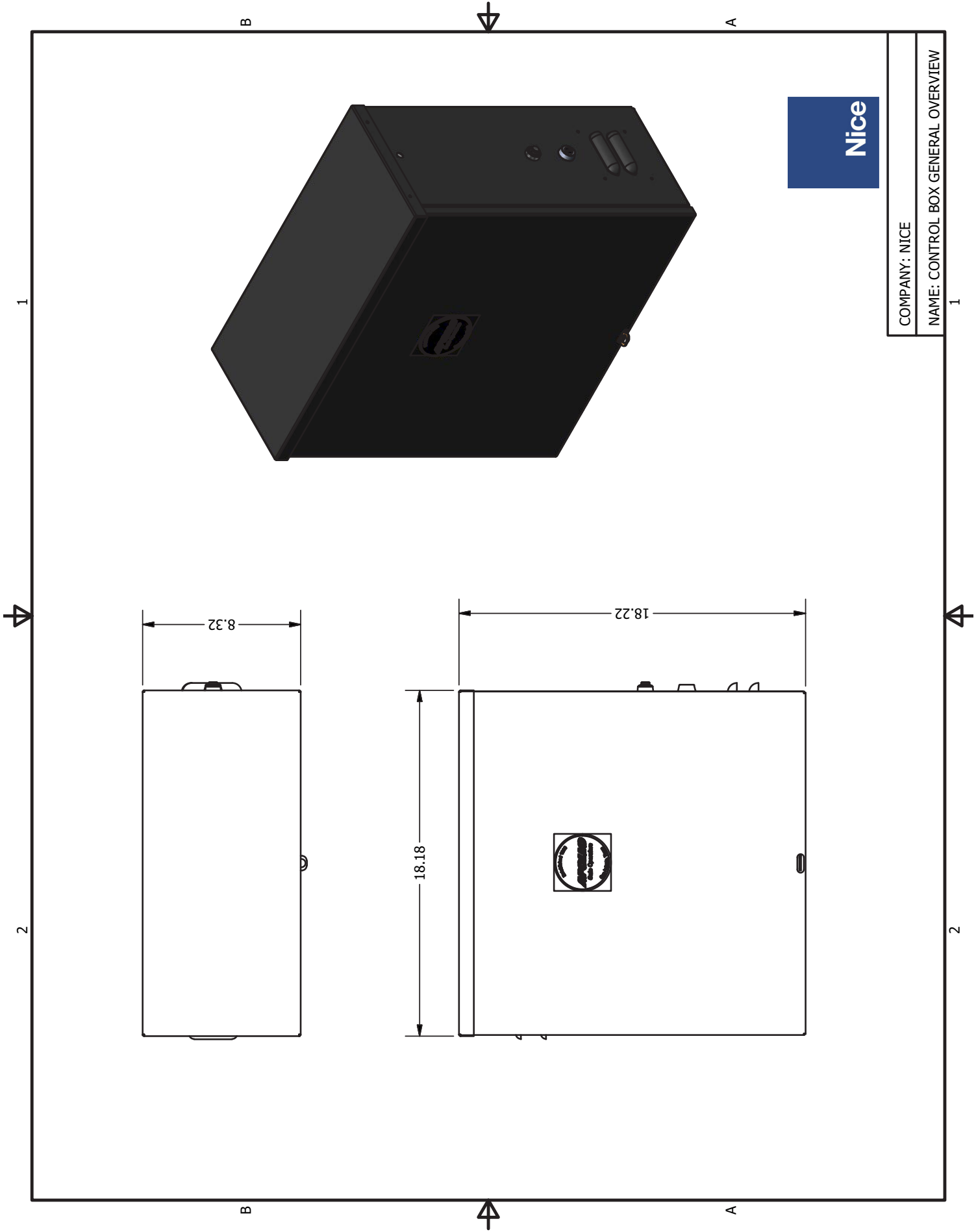

COMPANY: NICE
NAME: CONTROL BOX GENERAL OVERVIEW



COMPANY: NICE

NAME: ACTUATOR GENERAL VIEW

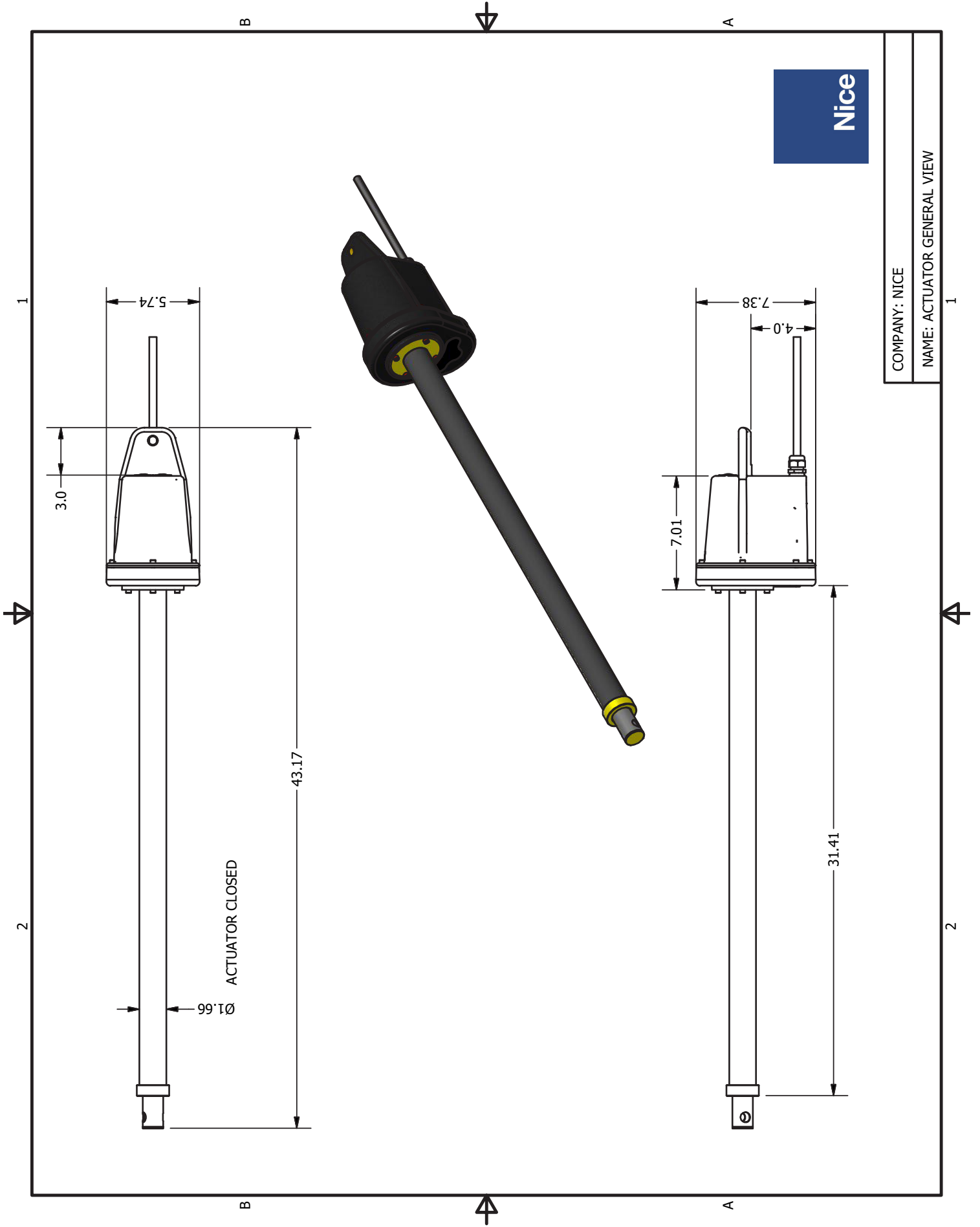

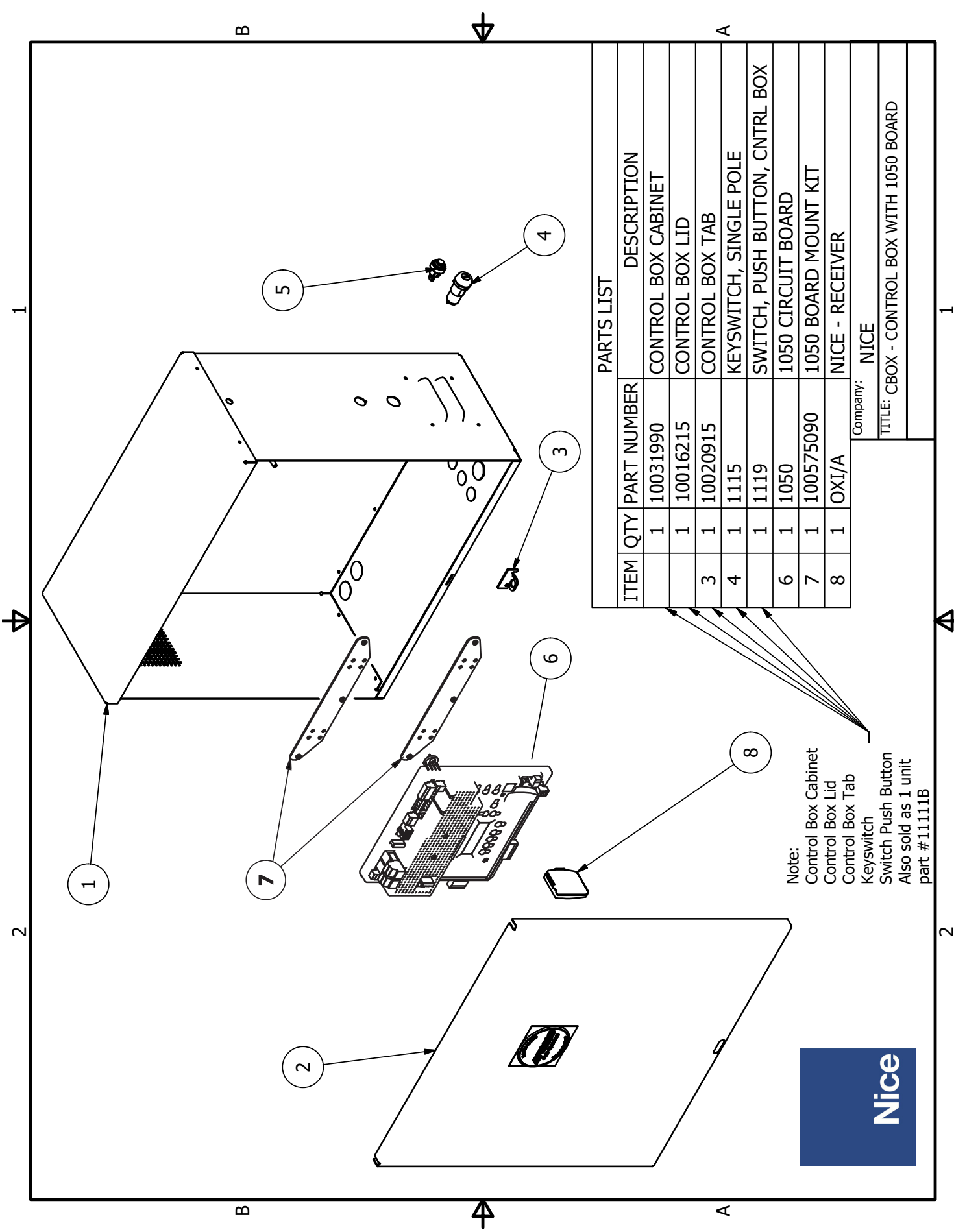

PARTS LIST

ITEM	QTY	PART NUMBER	DESCRIPTION
	1	10031990	CONTROL BOX CABINET
	1	10016215	CONTROL BOX LID
3	1	10020915	CONTROL BOX TAB
4	1	11115	KEYSWITCH, SINGLE POLE
	1	1119	SWITCH, PUSH BUTTON, CNTRL BOX
6	1	1050	1050 CIRCUIT BOARD
7	1	100575090	1050 BOARD MOUNT KIT
8	1	OXI/A	NICE - RECEIVER

Company: NICE

TITLE: CBOX - CONTROL BOX WITH 1050 BOARD

Note:
 Control Box Cabinet
 Control Box Lid
 Control Box Tab
 Keyswitch
 Switch Push Button
 Also sold as 1 unit
 part #11111B



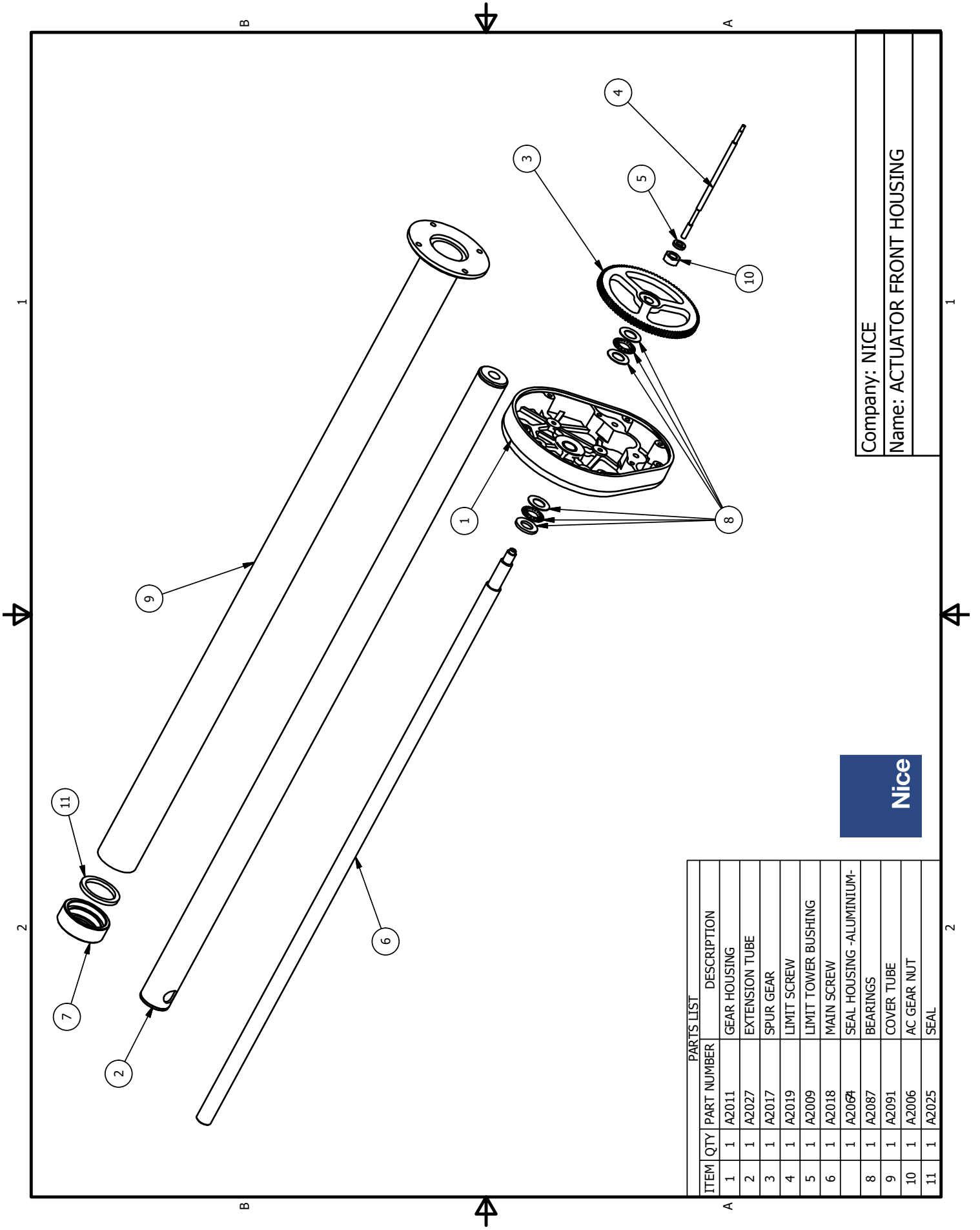

PARTS LIST	
ITEM	DESCRIPTION
1	GEAR HOUSING
2	EXTENSION TUBE
3	SPUR GEAR
4	LIMIT SCREW
5	LIMIT TOWER BUSHING
6	MAIN SCREW
7	SEAL HOUSING -ALUMINIUM-
8	BEARINGS
9	COVER TUBE
10	AC GEAR NUT
11	SEAL



Company: NICE
 Name: ACTUATOR FRONT HOUSING

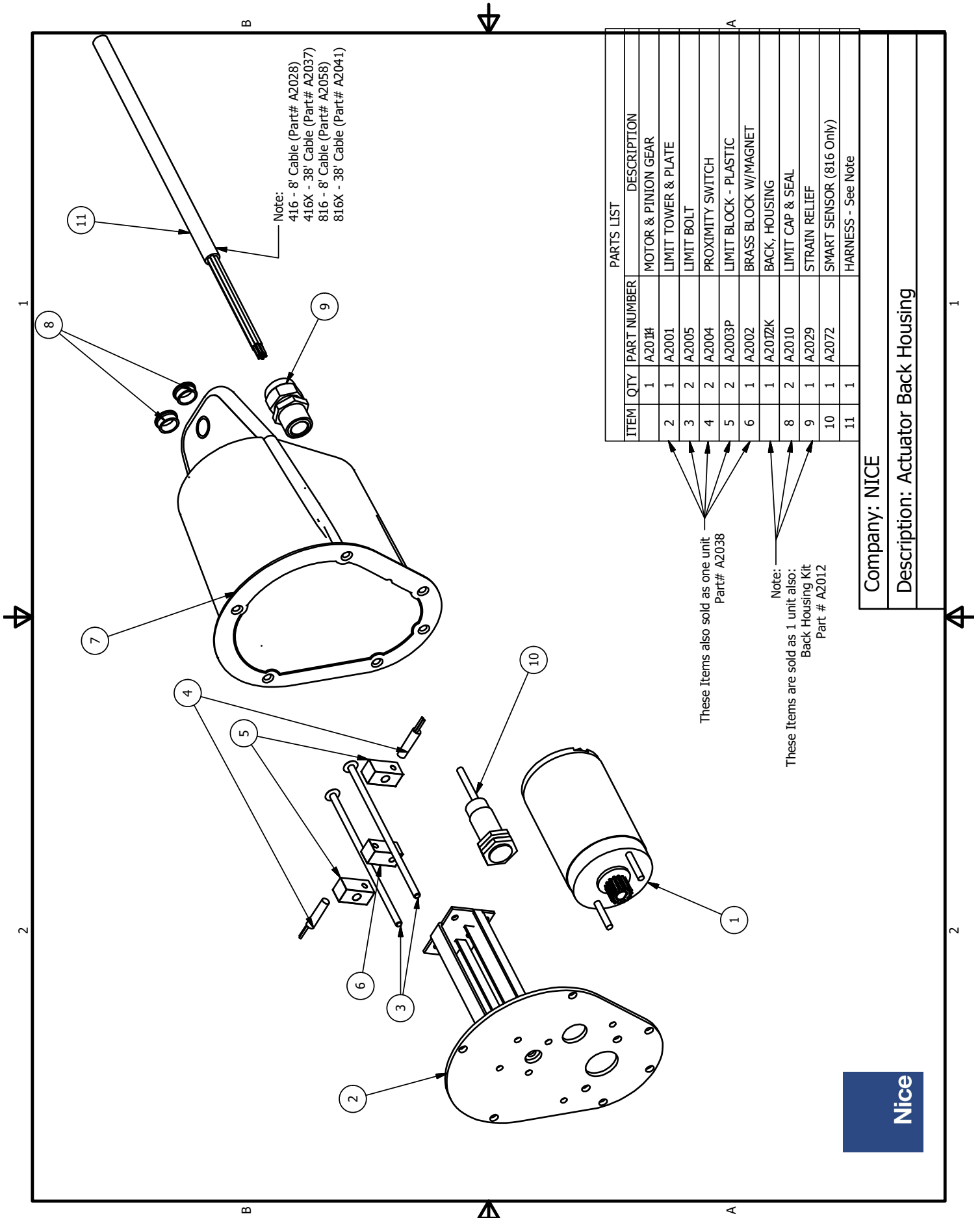

Note:
 416 - 8' Cable (Part# A2028)
 416X - 38' Cable (Part# A2037)
 816 - 8' Cable (Part# A2058)
 816X - 38' Cable (Part# A2041)

PARTS LIST		
ITEM	QTY	DESCRIPTION
1	1	MOTOR & PINION GEAR
2	1	LIMIT TOWER & PLATE
3	2	LIMIT BOLT
4	2	PROXIMITY SWITCH
5	2	LIMIT BLOCK - PLASTIC
6	1	BRASS BLOCK W/MAGNET
7	1	BACK, HOUSING
8	2	LIMIT CAP & SEAL
9	1	STRAIN RELIEF
10	1	SMART SENSOR (816 Only)
11	1	HARNESS - See Note

These Items also sold as one unit
 Part# A2038

Note:
 These Items are sold as 1 unit also:
 Back Housing Kit
 Part # A2012

Company: NICE

Description: Actuator Back Housing



Nice Group USA Limited Warranty – 2 (TWO) YEARS

Nice Group USA (“Manufacturer”) warrants this product shall be free from defects in materials and workmanship for a period of 2 years from the manufacture date. These warranties are in lieu of all other warranties expressed or implied and shall be considered void if the product is damaged due to, but not limited to, improper installation, improper use, terrorism or acts of God. The proper operation of this product is dependent on your compliance with the instructions regarding installation, operation, maintenance, and testing. Failure to comply strictly with those instructions will void this limited warranty in its entirety.

If, during the 2 year time period from the date of manufacture, this product appears to contain a defect covered by this limited warranty, **call the manufacturer service center at 1-800-226-0178** before uninstalling and/or dismantling this product. The technical assistance department at the manufacturer will discuss the problems you are experiencing in order to confirm the product defect. You will provide the information from the dated proof of purchase receipt to confirm the warranty period or the technician will confirm your extended warranty period through your registration information on file. The technician will give you the shipping information you need to return your product. Your product must be returned to the manufacturer service center in a prepaid and insured manner. Should your product be covered under the warranty policy, your product will be repaired, replaced with a factory rebuilt product or replaced with a new product (at the manufacturer’s discretion) at no cost to you and sent back to you via standard ground freight.

THIS WARRANTY AND THE OBLIGATIONS AND LIABILITIES OF MANUFACTURER ARE EXCLUSIVE AND IN LIEU OF ALL OTHER WARRANTIES, EXPRESS OR IMPLIED, INCLUDING ANY IMPLIED WARRANTY OF MERCHANTABILITY OR FITNESS FOR A PARTICULAR PURPOSE. Under no circumstances shall the manufacturer be liable for consequential, incidental or special damages of any kind whatsoever. The manufacturer’s liability for a breach of warranty, breach of contract, negligence or strict liability cannot exceed the cost of the warranted product. No person is authorized to assume for the manufacturer any other liability in connection with the sale of this product.

39 - INSTALLATION CHECKLIST

Left box is for installer check off and the right box is for customer check off.

- 1. The gate has been checked to make sure it is level and moves freely in both directions.
- 2. Potential pinch areas have been guarded so as to be inaccessible OR have contact and/or non-contact obstruction sensing devices installed.
- 3. The installer has installed one or more contact or non-contact obstruction sensing devices, in compliance with UL325 requirements for this installation.
- 4. If pedestrian traffic is expected, a separate pedestrian gate has been installed, a minimum of seven feet from the gate. The customer has been informed that all pedestrian traffic must use the pedestrian gate.
- 5. Warning signs have been installed on each side of the gate in highly visible locations. The customer has been informed that these signs must remain at all times.
- 6. There are no controls installed on the gate operator, or within 8 feet of the gate.
- 7. The installer has properly adjusted the obstruction sensing feature and has tested the gate to make sure that the gate stops and reverses a short distance with minimal resistance applied (Approximately 40 lbs. on a swing gate, at the end of the gate).
- 8. The installer has instructed the customer in the proper use of the gate operator and reviewed all of the operational functions, obstruction sensing devices, warning beeper and reset, etc.
- 9. The installer has instructed the customer in the proper way of disconnecting the operator. Manual disconnect must never be used while the gate is in motion. The power must be turned off and battery disconnected before disengaging the operator.
- 10. The installer has reviewed all safety instructions with the customer, and has left the safety instructions and owner's manual for their reference.
- 11. The installer has answered any questions the customer has regarding the operation of the gate operator and gate operator safety precautions.
- 12. The installer has explained to the customer that a regular maintenance schedule for both the gate and the gate operator is recommended.

Installation Acceptance

Address where opener is located

Installer name, number and address

End user name and telephone number

FRENCH TRANSLATIONS

The following French translations provided below are found in the Safety Section located at the beginning of the manual.

English	French
<p>IMPORTANT SAFETY INSTRUCTIONS WARNING – To reduce the risk of injury or death:</p>	<p>INSTRUCTIONS DE SÉCURITÉ IMPORTANTES AVERTISSEMENT – Pour réduire les risques de blessures et de mort :</p>
<p>1. READ AND FOLLOW ALL INSTRUCTIONS.</p>	<p>1. LISEZ CETTE NOTICE ET CONFORMEZ-VOUS AUX MISES EN GARDE</p>
<p>2. Never let children operate or play with gate controls. Keep the remote control away from children.</p>	<p>2. Ne laissez jamais les enfants manoeuvrer les commandes de la barrière ou jouer avec celles-ci. Laissez la télécommande hors de la portée des enfants.</p>
<p>3. Always keep people and objects away from the gate. NO ONE SHOULD CROSS THE PATH OF THE MOVING GATE.</p>	<p>3. Tenez toujours à l'écart de la barrière toute personne ou tout objet avoisinant. IL NE FAUT JAMAIS PASSER DANS LA TRAJECTOIRE D'UNE BARRIÈRE EN MOUVEMENT.</p>
<p>4. Test the gate operator monthly. The gate MUST reverse on contact with a rigid object or stop when an object activates the non-contact sensors. After adjusting the force or the limit of travel, retest the gate operator. Failure to adjust and retest the gate operator properly can increase the risk of injury or death.</p>	<p>4. Vérifiez le fonctionnement de l'ouvre-barrière une fois par mois. Le sens de la course DOIT s'inverser lorsque la barrière entre en contact avec un objet dur ou la barrière DOIT s'arrêter lorsqu'un objet active les capteurs sans contact. Vérifiez à nouveau l'ouvre-barrière après tout réglage de la force de déclenchement ou du seuil de fin de course. Un réglage incorrect de l'ouvre-barrière ou l'omission de vérifier à nouveau le fonctionnement de l'ouvre-barrière peut causer des blessures, voire la mort.</p>
<p>5. Use the emergency release only when the gate is not moving.</p>	<p>5. Ne déclenchez le dispositif de désaccouplement d'urgence que lorsque la barrière ne bouge pas.</p>
<p>6. KEEP GATES PROPERLY MAINTAINED. Read the user's manual. Have a qualified service person make repairs to gate hardware.</p>	<p>6. ASSUREZ-VOUS QUE LA BARRIÈRE EST CORRECTEMENT ENTRETENUE. Lisez le manuel de l'utilisateur. Confiez la réparation du matériel de la barrière à un technicien qualifié.</p>
<p>7. The entrance is for vehicles only. Pedestrians must use separate entrance.</p>	<p>7. La voie d'accès est réservée aux véhicules seulement. Les piétons doivent utiliser une voie d'accès différente.</p>
<p>8. SAVE THESE INSTRUCTIONS.</p>	<p>8. CONSERVEZ CES INSTRUCTIONS.</p>

English	French
Install the gate operator only when:	N'installez l'ouvre-barrière que si :
The operator is appropriate for the construction of the gate and the usage Class of the gate,	l'ouvre-barrière est approprié pour la structure et la classe d'utilisation de la barrière;
All openings of a horizontal slide gate are guarded or screened from the bottom of the gate to a minimum of 1.83 m (6 ft) above the ground to prevent a 57.2 mm (2-1/4 inch) diameter sphere from passing through the openings anywhere in the gate, and in that portion of the adjacent fence that the gate covers in the open position,	toutes les ouvertures de la barrière coulissante sont protégées ou grillagées du bas de la porte jusqu'à un minimum de 1,83 m (6 pi) du sol si bien qu'une sphère de 57,2 mm (2 1/4 po) de diamètre ne peut passer par une ouverture au niveau de la barrière et de la portion de la clôture adjacente que la barrière couvre en position ouverte;
All exposed pinch points are eliminated or guarded, and	tous les points de pincement sont éliminés ou protégés;
Guarding is supplied for exposed rollers.	des protections sont fournies pour les galets exposés.
The operator is intended for installation only on gates used for vehicles. Pedestrians must be supplied with a separate access opening. The pedestrian access opening shall be designed to promote pedestrian usage. Locate the gate such that persons will not come in contact with the vehicular gate during the entire path of travel of the vehicular gate.	L'ouvre-barrière est destiné à n'être installé que sur des barrières utilisées pour les véhicules. Il faut fournir une autre voie d'accès aux piétons. La voie d'accès pour les piétons doit être conçue pour favoriser le passage des piétons. Placez la barrière de sorte que personne ne puisse entrer en contact avec la barrière pour les véhicules sur l'ensemble de sa trajectoire
The gate must be installed in a location so that enough clearance is supplied between the gate and adjacent structures when opening and closing to reduce the risk of entrapment. Swinging gates shall not open into public access areas.	Pour réduire les risques de coincement lors de l'ouverture et de la fermeture, la barrière doit être installée dans un endroit où la barrière et les structures avoisinantes sont suffisamment éloignées l'une de l'autre. Les barrières battantes ne doivent pas ouvrir dans une zone d'accès public.
The gate must be properly installed and work freely in both directions prior to the installation of the gate operator. Do not over-tighten the operator clutch or pressure relief valve to compensate for a damaged gate.	La barrière doit être bien installée et fonctionner librement dans les deux directions avant d'entreprendre l'installation de l'ouvre-barrière. Ne serrez pas trop l'embrayage ou la soupape de surpression de l'ouvre-barrière pour compenser une barrière endommagée.

English	French
<p>Controls intended for user activation must be located at least 1.83 m (6 ft) away from any moving part of the gate and where the user is prevented from reaching over, under, around or through the gate to operate the controls. Exception: Emergency access controls only accessible by authorized personnel (e.g. fire, police, EMS) may be placed at any location in the line-of-sight of the gate.</p>	<p>Les commandes destinées à l'activation par l'utilisateur doivent être situées à au moins 1,83 m (6 pi) des pièces mobiles de la barrière et à un endroit où l'utilisateur ne peut pas atteindre les commandes par le dessus, par le dessous, par les côtés et au travers de la barrière. Exception : Les commandes d'accès d'urgence accessibles au personnel autorisé seulement (p. ex. pompier, policier, SMU) peuvent être placées à tout endroit dans le champ de visibilité de la barrière.</p>
<p>The Stop and/or Reset button must be located in the line of-sight of the gate. Activation of the reset control shall not cause the operator to start.</p>	<p>Le bouton d'arrêt, le bouton de réenclenchement ou ces deux boutons doivent être situés dans le champ de visibilité de la barrière. L'activation des commandes de réenclenchement ne doit pas mettre en marche l'ouvrebarrière.</p>
<p>A minimum of two (2) WARNING SIGNS shall be installed, in the area of the gate. Each placard is to be visible by persons located on the side of the gate on which the placard is installed.</p>	<p>Au moins deux panneaux de mise en garde doivent être installés dans la zone de la barrière. Chaque étiquette doit être visible des personnes situées de chaque côté de la barrière sur laquelle l'étiquette est installée.</p>
<p>For gate operators utilizing a non-contact sensor</p>	<p>Pour les ouvre-barrières qui fonctionnent avec des capteurs</p>
<p>See instructions on the placement of non-contact sensors for each Type of application,</p>	<p>Voir les instructions sur le positionnement des capteurs sans contact pour chaque type d'utilisation.</p>
<p>Care shall be exercised to reduce the risk of nuisance tripping, such as when a vehicle, trips the sensor while the gate is still moving, and</p>	<p>Des précautions doivent être prises pour réduire les risques de déclenchement inutile, comme lorsqu'un véhicule déclenche le capteur alors que la barrière est encore en mouvement.</p>
<p>One or more non-contact sensors shall be located where the risk of entrapment or obstruction exists, such as the perimeter reachable by a moving gate or barrier.</p>	<p>Un capteur sans contact ou plus doit être situé où il existe un risque de coincement ou d'obstruction, comme dans l'espace que peut occuper la barrière lorsqu'elle est en mouvement.</p>
<p>For a gate operator utilizing a contact sensor</p>	<p>Pour les ouvre-barrières qui fonctionnent avec des capteurs</p>
<p>One or more contact sensors shall be located where the risk of entrapment or obstruction exists, such as at the leading edge, trailing edge, and postmounted both inside and outside of a vehicular horizontal slide gate.</p>	<p>Au moins un capteur de contact doit être situé où il existe un risque de coincement ou d'obstruction, comme sur le bord d'ouverture, sur le bord de fermeture et sur les poteaux montés sur l'intérieur ou l'extérieur d'une barrière coulissante pour véhicules.</p>

English	French
A hardwired contact sensor shall be located and its wiring arranged so that the communication between the sensor and the gate operator is not subjected to mechanical damage.	Un capteur de contact doit être installé et câblé de sorte à éviter que la communication entre le capteur et l'ouvrebarrière soit gênée par des dommages mécaniques.
A wireless device such as one that transmits radio frequency (RF) signals to the gate operator for entrapment protection functions shall be located where the transmission of the signals are not obstructed or impeded by building structures, natural landscaping or similar obstruction. A wireless device shall function under the intended end-use conditions.	Un dispositif sans fil, comme un appareil qui transmet des signaux de radiofréquence (RF) à l'ouvre-barrière pour prévenir le coincement, doit être situé à un endroit où la transmission des signaux ne sera pas obstruée ou gênée par des structures, des arbres ou d'autres obstacles similaires. Un dispositif sans fil doit fonctionner selon les conditions d'utilisation finale prévues.
One or more contact sensors shall be located on the inside and outside leading edge of a swing gate. Additionally, if the bottom edge of a swing gate is greater than 152 mm (6 inches) but less than 406 mm (16 inches) above the ground at any point in its arc of travel, one or more contact sensors shall be located on the bottom edge.	Au moins un capteur de contact doit être situé sur les bords d'ouverture intérieur et extérieur d'une barrière battante. De plus, si le dessous d'une barrière battante est situé à plus de 152 mm (6 po) mais à moins de 406 mm (16 po) du sol à l'un des points de sa trajectoire, au moins un capteur de contact doit être situé sur le bord inférieur.

Contact us

Nice
6705 S. 209th St., Suite 101
Kent, WA 98032-2327
Ph. +1.253.867.3700
Fax +1.253.867.3702

www.hysecurity.com
www.facebook.com/hsgateoperators

