

14-RK10

300/433-MHZ RESIDENTIAL KEYPAD

FEATURES

- 10 four-digit access-code capacity
- Personal master code
- Limited-use codes
- Wireless range up to 50 feet
- "3 strikes, you're out" security
- Audible-tone and LED feedback
- Luminescent keypad
- Polycarbonate construction
- Dust cover



WORKS WITH

- Ridge 2.0 Transceiver
- Receiver 300 or other 300-MHz receivers

RIDGE
WIRELESS™



GOES WHERE YOU GO

No wires mean freedom—this keypad can be located and mounted anywhere you need it.

FITS YOUR NEEDS

This keypad can connect with the Ridge 2.0 Transceiver, Receiver 300, or many other 300-MHz receivers and fitting every need.

LASTING PROTECTION

The handy flip-up dust cover will keep your keypad protected from dust and damage.

GO WIRELESS

Our Ridge Wireless™ technology allows two-way wireless connection, making your system more versatile and more responsive.

SPECIFICATIONS (KEYPAD)

PHYSICAL

Dimensions 3.64"(H) x 2.99"(W) x 1.38"(D)
 Shipping Weight 1 lb.

ELECTRICAL

Input 3 VDC *

ENVIRONMENTAL

Operating Temperature -15 to 175 °F

* Includes two (2) AAA alkaline batteries.

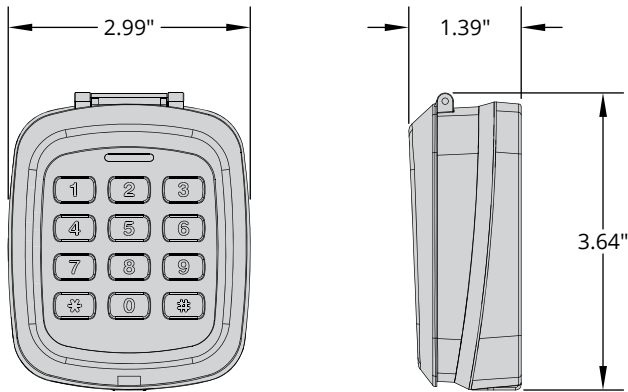

RELATED PRODUCTS



14-REC300
 Receiver 300
 300-MHz Receiver



14-REC20
 Ridge 2.0 Transceiver
 433-MHz Transceiver



14-500
 Ridge 2.0
 433-MHz Keypad and Transceiver

For more information, visit us online:
securitybrandsinc.com

 **SECURITY BRANDS INC**[™]
 your *partner* in access control

(972) 474-6390 sales@securitybrandsinc.com 2210 Executive Dr
 Garland, TX 75041