

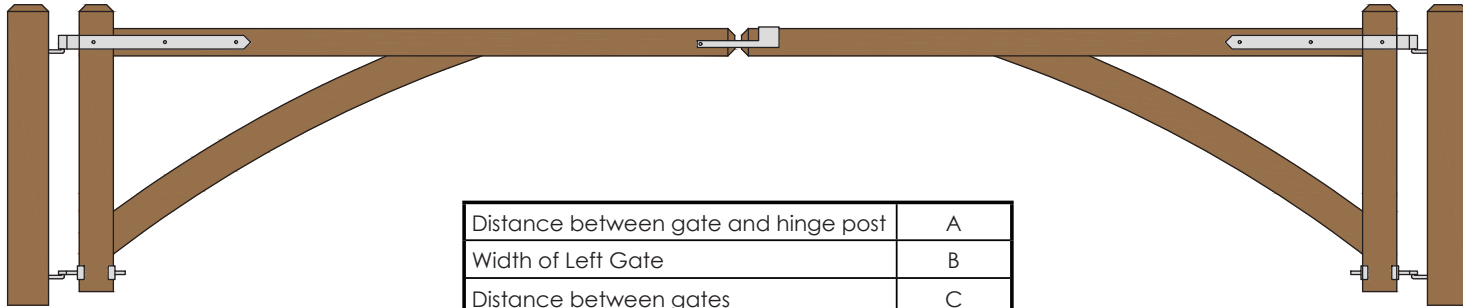

# WELDON BARRIER GATE PLAN

## Double Gate Configuration - Curved Support Design

Two 8' wide by 44" tall gate - hung between the posts - using Central Eye Hinges (Product Code #8312).



Distance between gate and hinge post	A
Width of Left Gate	B
Distance between gates	C
Width of Right Gate	D
Distance between gate and hinge post	E
Total distance between posts	F

HARDWARE REQUIRED						
Finish Options Available	Galvanized Finish		Black Powder Coat over Galvanized Finish			
<b>Plan Specified Required Hardware</b>						<b>Central Eye Hinge Advantages</b> Opens both ways 100 degrees. Incredible amount of adjustment. Easy operation. Very strong.
<b>Both Sets Include:</b> <i>(All fasteners are included with hardware)</i>	2 of 8312-S242		2 of 8312-S24P			
	two 24 inch double strap (8312-542 or 8312-54SP) two adjustable bottom gate fitting (8250-002 or 8250-00P) four 12" adjustable gate pin (8801-122 or 8801-12P)					
<b>Central Latch Option</b>						<b>Dimensions (feet and inches)</b> A   B   C   D   E   F
Throw Over Gate Loop(shown)	4200-032		4200-03SP			4.5"   8'   1"   8'   4.5"   16' - 10"
<b>Optional Gate Holdback</b>						A means of keeping gates open
	4270-122		4270-12SP			
Lumber Required						
Posts	2 of 8' x 6" x 6" (usually dressed out at 5.5" x 5.5")					
Rails	6 of 8' x 1" x 5.5"					
Stiles	4 of 8' x 1" x 5.5"					
Diagonals	2 of 8' x 1" x 5.5" (straight support design) or 4 of 8' x 1" x 5.5" (curved support design)					
Filler Blocks	use off cuts from above					
<b>Fasteners Required for Gate Construction</b>						
2 of <b>FP-WeldonBarr.</b> - Fastener Pack for Weldon Barrier Gate Build (Includes 40 of 1.75" wood screws, 2 of 3/8" dowel rod and 9 of 3.5" HDG carriage bolts, nuts and washers)						

Download includes this materials list, component cutting and layout sheet.  
 For a complete listing of our Free Gate Plans, please visit [snugcottagehardware.com](http://snugcottagehardware.com)

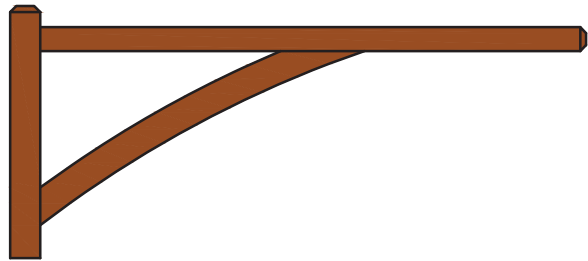

8' CURVED BARRIER GATE

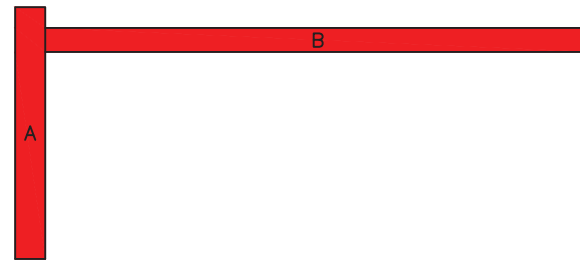

FIRST LAYER

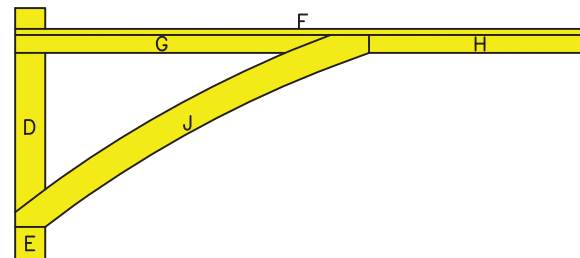

SECOND LAYER

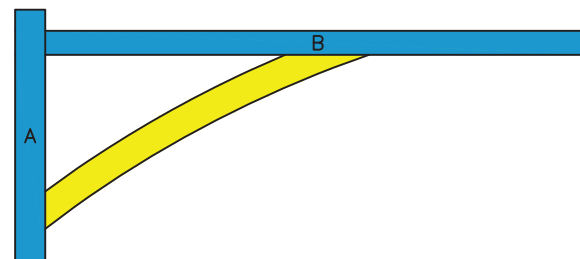

THIRD LAYER

BUILDING STEPS

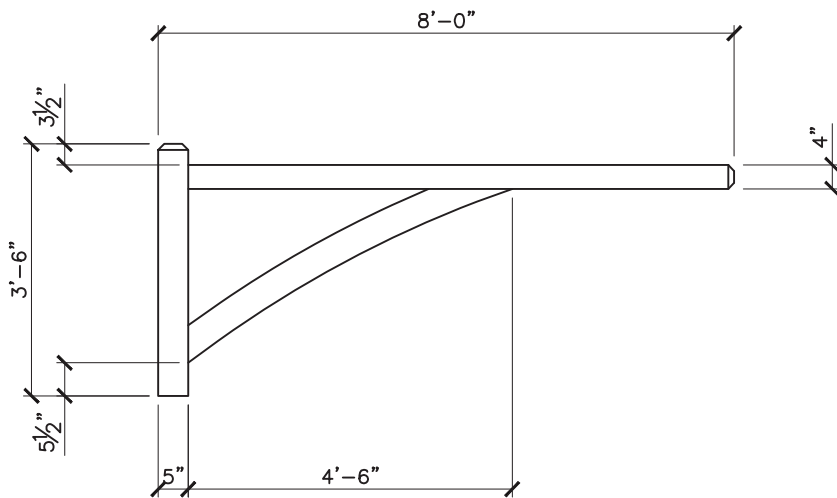

GATE DIMENSIONS

PROPERTY OF:



PRODUCT DESCRIPTION:

8' WELDON BARRIER GATE  
 CURVED SUPPORT DESIGN  
 ALL DIMENSIONS ±0.125"

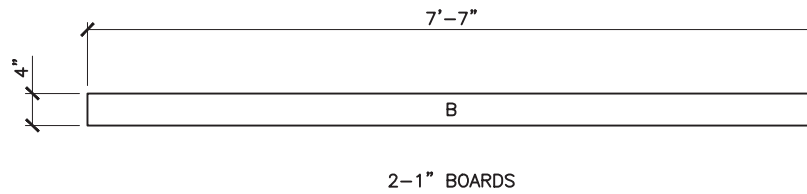
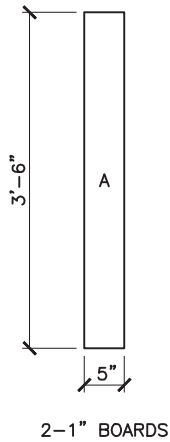

FIRST AND THIRD LAYER COMPONENTS

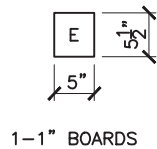
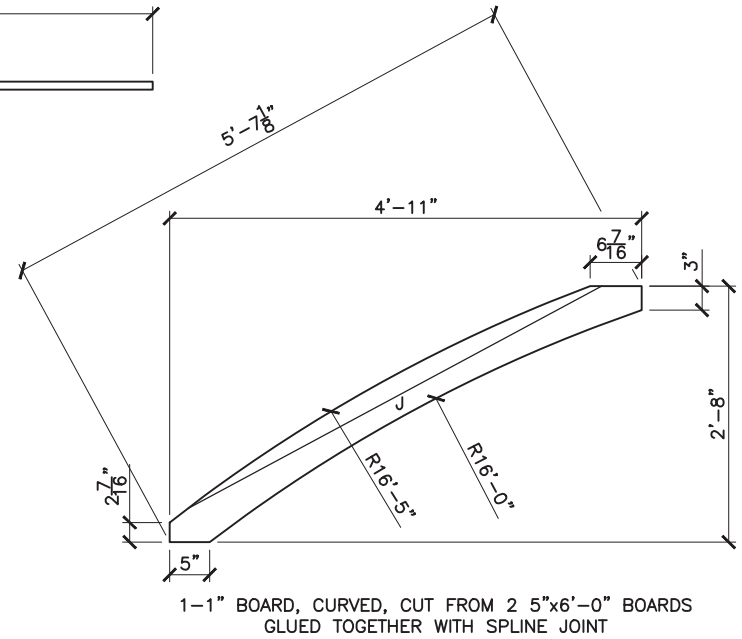
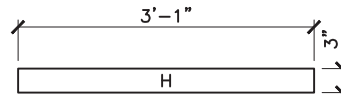
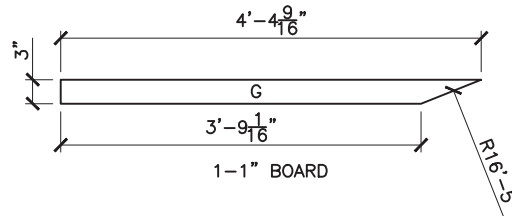
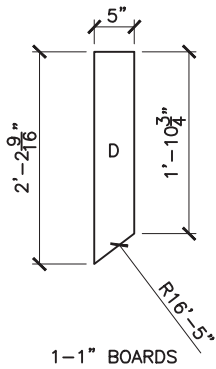
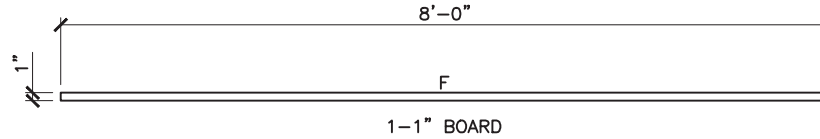
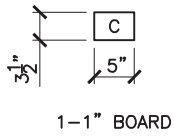

SECOND LAYER COMPONENTS

PROPERTY OF:



PRODUCT DESCRIPTION:

8' WELDON BARRIER GATE CURVED SUPPORT DESIGN COMPONENTS

ALL DIMENSIONS ±0.125"