

ADVANTAGE DKE



26 SERIES

100- AND 500-CODE ECONOMY KEYPADS

FEATURES

- Control up to 2 gates/doors (26-500)
- Control 1 gate/door (26-100SG)
- 500 four-digit code capacity (26-500)
- 100 four-digit code capacity (26-100SG)
- Latch code
- Personal master code
- Variable relay time
- Event input (26-500 only)
- Audible-tone feedback
- Non-volatile memory
- Backlit keypad (26-500 only)



ADVANTAGE

SOLID ACCESS CONTROL FOR OVER 35 YEARS

NO-NONSENSE OPERATION

If you're looking for keypads that are easy to program and easy to use, look no further!

THE SMART SOLUTION

These keypads have all the features you want and then some but still come in at a price that will fit any budget.

STURDY AND DURABLE

All our products are made from high-quality materials that will last for years to come.

PROGRAMMING YOU KNOW

Quick, simple, and familiar, the basic programming steps on the keypad are identical to those on all our keypads.



SPECIFICATIONS

PHYSICAL

26-500

Dimensions 5.41"(H) x 4.07"(W) x 3.38"(D)
 Shipping Weight 4 lbs.

26-100SG

Dimensions 4.50"(H) x 2.75"(W) x 0.75"(D)
 Shipping Weight 1 lb.

ELECTRICAL

Input 12-24 VAC/DC
 power supply not included
 Current Draw less than 41 mA @ 12 VDC
 (26-500) less than 22 mA @ 24 VDC
 with relay latched and backlit components on

RELAY

Contact Rating 1 A @ 24 V / .5 A @ 120 V
 DC Load / AC Load
 Variable Relay Time 1-999 / 1-9 seconds
 26-500 / 26-100SG

ENVIRONMENTAL

Operating Temperature -15 to 175 °F

MOUNTING (26-500)

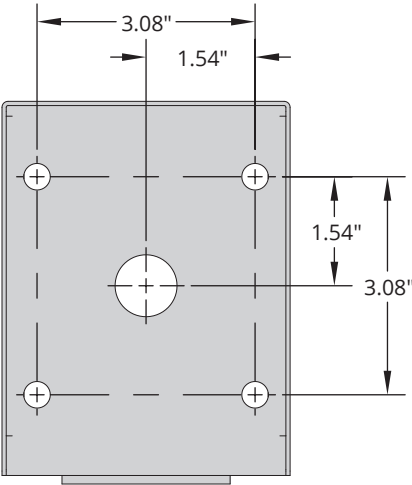

HOLE SIZES

Wiring pass through 0.88"
 Mounting holes (x4) 0.38"

Unit includes mounting hardware.

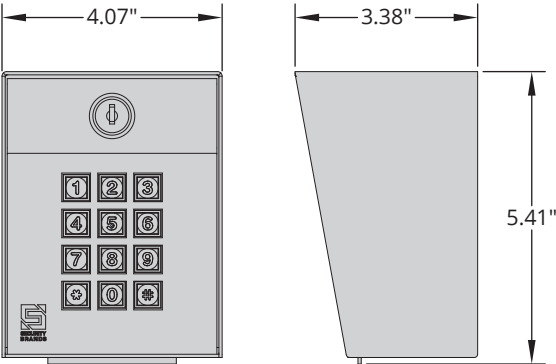

26-500 shown

AVAILABLE MODELS



26-500
 Post Mount



26-100SG
 Single Gang

For more information, visit us online:
securitybrandsinc.com

