



**1** Carefully unpack box.

**2** Make sure you have everything shown here.

Keypad Unit

Key

Carriage Bolt  
( 4x )

Hex Nut  
( 4x )

**3** Unlock and remove front panel of keypad unit; then using carriage bolts and hex nuts, attach unit to pedestal as shown.

## What's what?

Important components labeled

### Power and Relay Terminals

For wiring to gate operator or door opener and power  
**POWER MUST BE 7-14 VDC!**

### Reset Button

For performing reset procedures

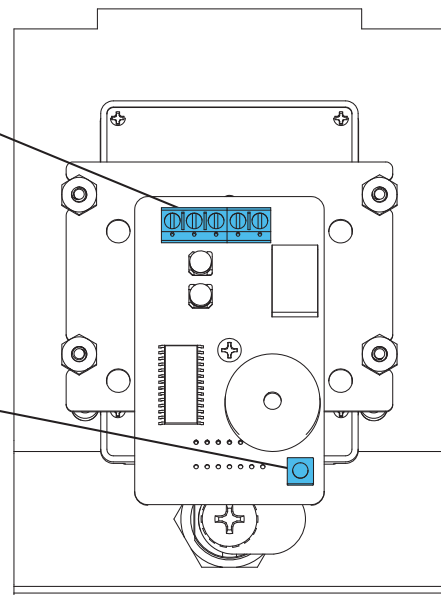

### Keypad Unit Front Panel

Shown as it would appear with front panel inserted into enclosure as in Step 4.

**4** For ease of wiring, insert front panel into enclosure as shown.

## CAUTION!

Double check your wires! You must wire from positive on keypad unit to positive on your power source and negative on keypad unit to negative on your power source.

**Reverse polarity can damage keypad unit!**

## WARNING!

**AUTOMATIC GATES CAN CAUSE SERIOUS INJURY OR DEATH!**

**ALWAYS CHECK that the GATE PATH IS CLEAR BEFORE OPERATING!**

**REVERSING or other SAFETY DEVICES SHOULD ALWAYS BE USED!**

## 5a Make the connections

Wiring for Gate Operator or Door Opener

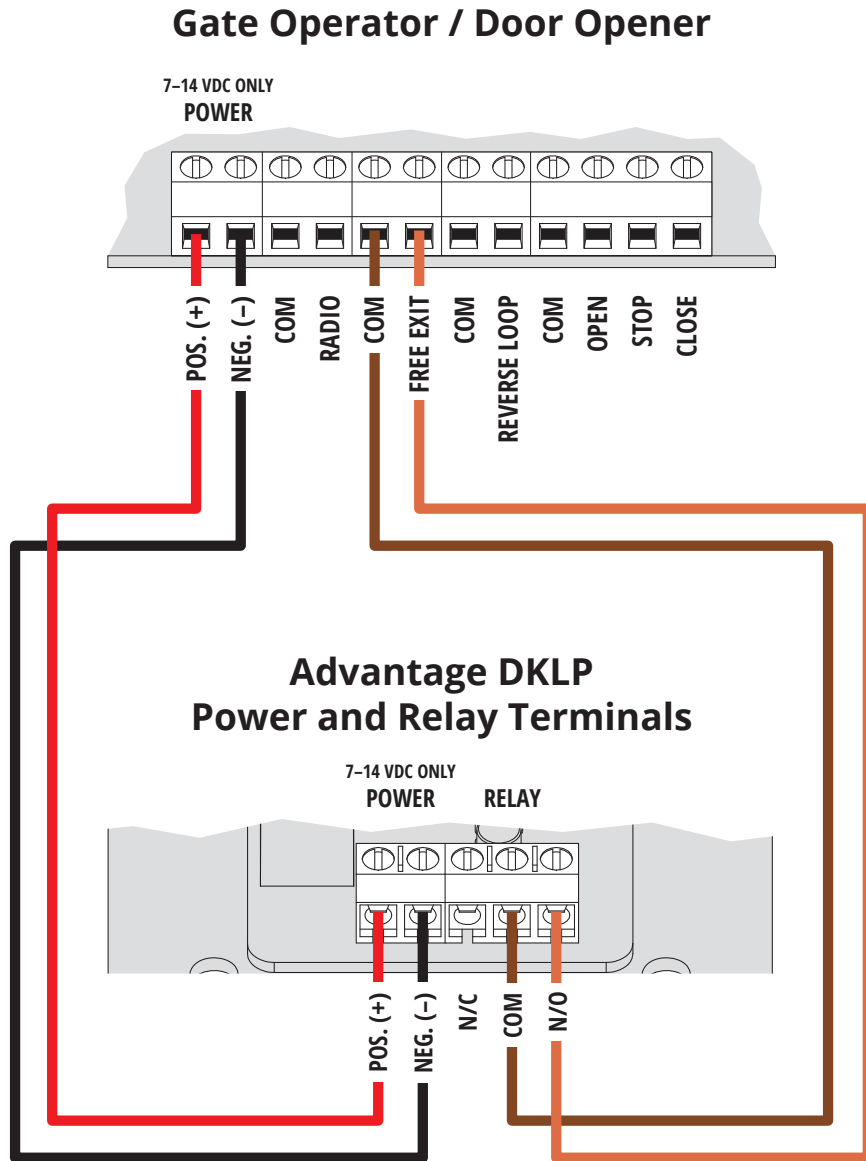

## 5b Make the connections

Wiring for Electric Door Strike

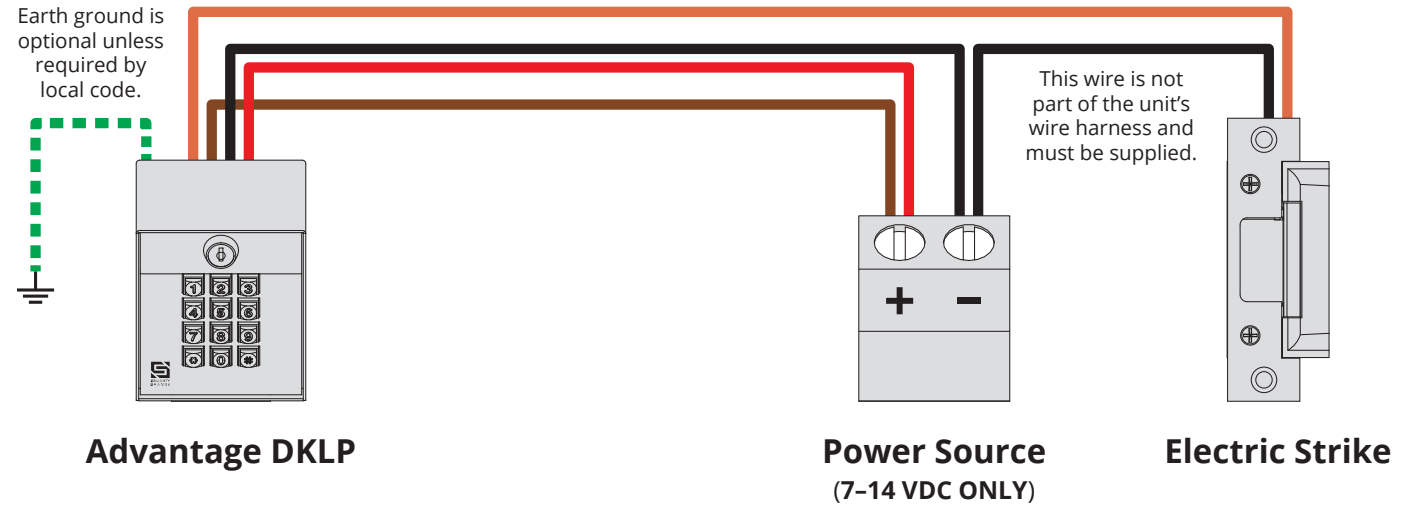

## 5c Make the connections

Wiring for Mag Lock

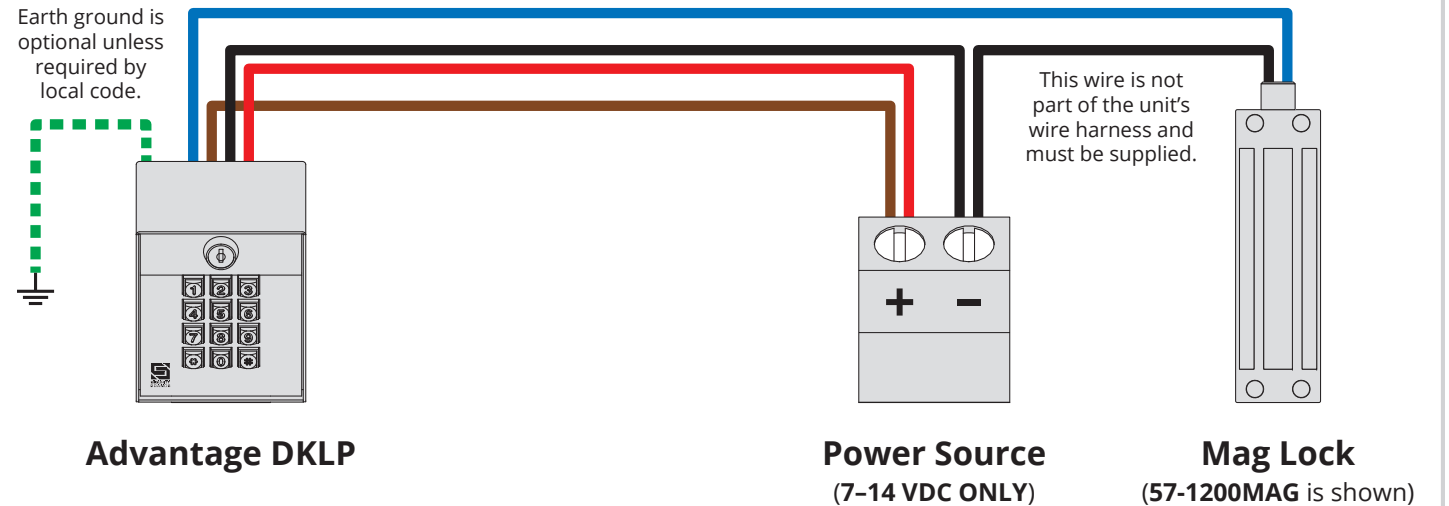



**6 Add Access Code(s).**  
(To add multiple codes, enter each of them before pressing pound key)

1 2 5 1 → 1 → \_ \_ \_ \_ → #

Master Code (1251 is default)      Sub Mode      Access Code(s) (4 digits; numbers only)

**NOTE:** The Master Code is for programming only and will not trigger the relay. The green arrow indicates a "good" tone on the keypad. An incorrect entry will sound a "bad" tone.

**7 Make sure gate path is clear; then enter access code on keypad and confirm gate opens.**



**INSTALLATION COMPLETE!**

Your system is ready to use.

**A1 Additional Programming**

**Delete Code(s)**  
(To delete multiple codes, enter each of them before pressing pound key)

1 2 5 1 → 2 → \_ \_ \_ \_ → #

Master Code (1251 is default)      Sub Mode      Code(s) to Be Deleted (4 digits; numbers only)

**Change Master Code**

1 2 5 1 → 3 → \_ \_ \_ \_ → #

Current Master Code (1251 is default)      Sub Mode      New Master Code (4 digits; numbers only)

**Set Latch Code**

1 2 5 1 → 5 → \_ \_ \_ \_ → #

Master Code (1251 is default)      Sub Mode      Latch Code (4 digits; numbers only)

**Things to Know**

**The Star Key (\*)**  
The star key deletes your current entry. If you happen to make a mistake keying in a code, simply press the star key to delete the entire entry and start over.

**The Pound Key (#)**  
The pound key is good for one thing and one thing only: exiting Programming Mode. Whenever you're in Programming Mode, simply press the pound key to get out.

**Master Reset Procedure**  
If for some reason the Master Code and/or Latch Code is forgotten, a reset procedure is available to remedy the situation.

This procedure can be found on **Page 4** of this guide.

**NOTE:** Green arrow indicates "good" tone on keypad. Always wait for good tone before moving on.

**Programming Sub Modes**

- 1 Add Access Code(s)
- 2 Delete Code(s)
- 3 Change Master Code
- 4 Set Relay Output Time
- 5 Set Latch Code
- 0 Delete All Codes

## A2 Additional Programming (continued)

### Set Relay Output Time



### Delete All Codes (Cannot Be Undone)

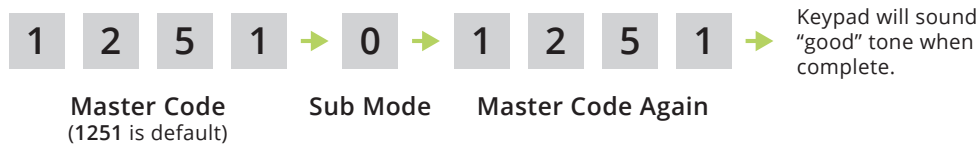

**NOTE:** Green arrow indicates "good" tone on keypad. Always wait for good tone before moving on.

## B Master Reset Procedure

This procedure is used if the Master Code is unknown, or if the Latch Code is unknown and the unit is in Latch Mode. All other codes will be retained after completing this procedure.

**NOTE:** If an error is made during these procedures, an "error" tone will sound, and you must start again from the beginning.

**Step 1 - Open front panel on unit.**

**Step 2 - Disconnect power.**

Remove one power wire from screw terminal on circuit board by unscrewing and removing.

**Step 3 - Press and hold Reset Button; reconnect power; then release Reset Button.**

Insert removed power wire back into screw terminal and screw down to secure. Unit will sound one (1) tone. Release Reset Button after you hear tone.

**Step 4 - Close front panel on unit.**

The Master Code is now reset to default (1251).



Call (972) 474-6390

Email [techsupport@securitybrandsinc.com](mailto:techsupport@securitybrandsinc.com)

We are available **Mon-Fri / 8am-5pm Central**



**SECURITY BRANDS INC™**  
your *partner* in access control