

**GateSolutions**  
by Codelocks



**Complete  
kits for  
gate and  
fence  
installations**

# GateSolutions

by Codelocks

## Simple and effective access control

Offering comprehensive kits for gate and fence installations, Gate Solutions by Codelocks provides a simple and effective access control solution for fenced perimeters and outdoor spaces. Available with selected locks from the Codelocks Mechanical, Electronic and Smart Lock ranges.

The Gate Box Kits and Gate Panic Hardware Kits contain all components required for straightforward installation. Featuring adjustable strike plates, dual backplate installation options as well as exit device hardware and accessories, these kits are fully versatile.

Suitable for indoor and outdoor applications, Gate Solutions by Codelocks is the ideal choice for pool areas, schools and colleges, hospitals, hotels, backyards - any restricted area that will benefit from controlling access, commercial or residential.



# Gate Box Kits

Gate Solutions by Codelocks provides simple and effective access control solutions for fenced perimeters / outdoor spaces. Gate Box Kits contain all components required for a straightforward installation. Suitable for indoor and outdoor applications.

## Key Features

- Easy, effective gate and fence installation
- Complete kits with all required components
- 14-gauge weldable steel boxes with pre-drilled fixing holes
- Supplied as raw steel, ready to paint
- Back to back installation options
- Keyed alike available on key override models
- Adjustable strike bracket with U-bolt fastener
- Available with Clean by Codelocks

## What does the Gate Box Kit include?



### Lock

The selected Codelock in it's box containing installation, operating / programming instructions, fastening bolts and latch.

### Gate Box

14-gauge steel. Easily weldable into a gate. Pre-drilled for specific Codelocks branded lock models. Adjustable strike bracket and mounting hardware.

### Latch Bracket

16-gauge steel. Powder coated using RAL #7035. Adjustable up to 3" gap between gate and post.

## Compatible Codelocks

Selected models from the Codelocks Mechanical, Electronic and Smart Lock ranges are available as part of the Gate Box Kits. From light duty, single code mechanical locks, to multi-user electronic locks and smart locks utilising MIFARE® compatible RFID technology - there's a lock to suit all applications.



## Applications

Codelocks Mechanical, Electronic and Smart Locks are suitable for installation to 4 different types of fencing. Some locks will be better suited to specific applications and fence types than others. To discuss your application and find the right lock for you, contact us.



Chain link



Wood



Vinyl



Ornamental steel



### CL200 Mechanical

Light duty mechanical locks with hexagonal knob handles, offering key override, deadbolt and tubular latch options.



### CL400 Mechanical

Medium duty locks with tubular latch and lever handles. Code free passage function and back to back options available.



### CL500 Mechanical

Heavy duty lock with tubular latch and lever handles. Code free passage function and back to back options available.



### CL600 Mechanical

Heavy duty locks with on-door code changes and key override. Code free passage function and back to back options available.



### CL4200 Electronic

Medium duty electronic lock with tubular latch, full size lever handles and key override. Up to 80 User Codes.



### CL5200 Electronic

Heavy duty electronic lock with tubular latch, full size lever handles and key override. Up to 80 User Codes.



### CL4500 Smart Lock

Medium duty smart lock. Combines smart technology with traditional keypad and RFID access credentials.



### CL5500 Smart Lock

Heavy duty smart lock. Combines smart technology with traditional keypad and RFID access credentials.



Stainless Steel finish



Brushed Steel finish

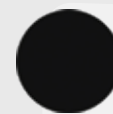

Marine Grade finish, specially enhanced to withstand harsh outdoor environments and coastal applications

# Technical Specifications

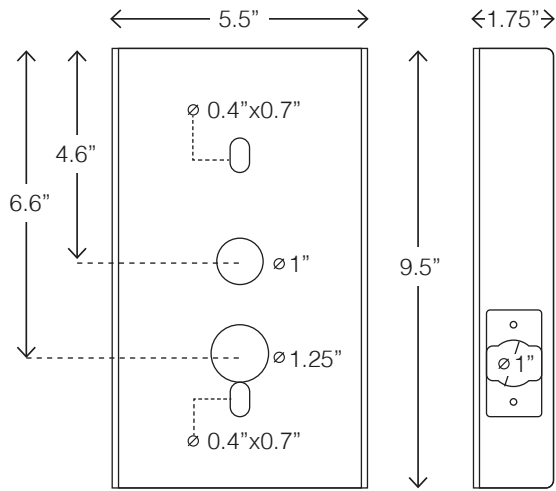

## Gate Box S1

Compatible with Codelocks:

- Mechanical CL200
- Mechanical CL400

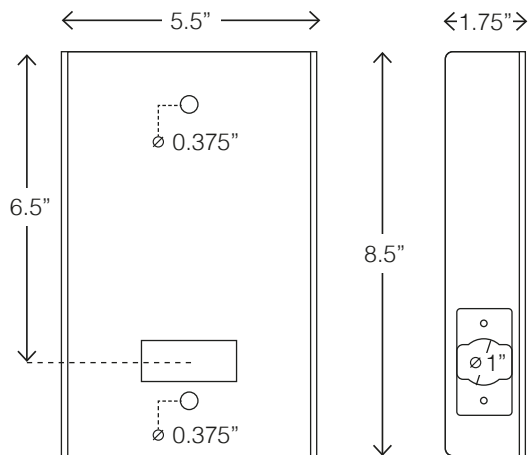

## Gate Box S2

Compatible with Codelocks:

- Mechanical CL500
- Electronic CL4200
- Smart CL4500

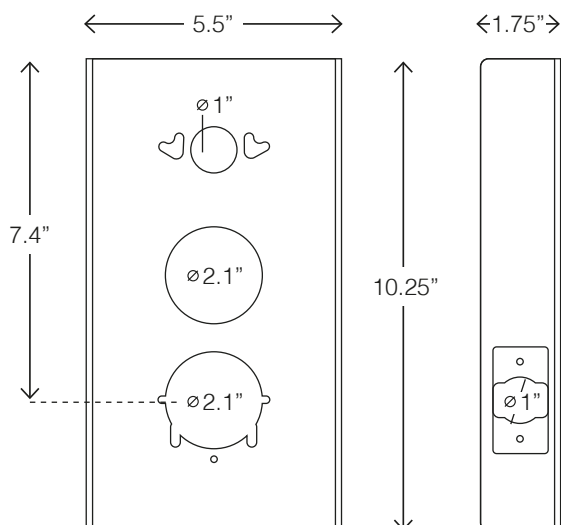

## Gate Box S3

Compatible with Codelocks:

- Mechanical CL600
- Electronic CL5200
- Smart CL5500





1 6

2 7

3 8

4 9

5 0

• C

CODELOCKS.COM

# Gate Panic Hardware Kits

Gate Solutions by Codelocks provides simple and effective access control solutions for fenced perimeters / outdoor spaces. Gate Panic Hardware Kits contain all components required for a straightforward installation. Suitable for indoor and outdoor applications.

## Key Features

- Easy, effective gate and fence installation
- Complete kits with all required components
- Powder coated and pre-drilled
- Alarm Kits available
- Stainless steel exterior rated Codelocks exit device
- Keyed alike available on key override models
- Key cylinder box for keyed gates available
- Available with Clean by Codelocks

## Available Panic Trims

Selected models from the Codelocks Mechanical, Electronic and Smart Lock ranges are available as part of the Gate Panic Hardware Kits. From heavy duty, single code mechanical locks, to multi-user electronic locks and smart locks utilising MIFARE® compatible RFID technology - there's a lock to suit all applications.



## What does the Gate Panic Hardware Kit include?



### Codelocks Panic Bar

The Codelocks CL.ED Series Exit Device is available in two sizes, 36" and 48".

- ANSI Grade 1
- Stainless steel
- Optional alarm kit available

### Components

- All items supplied with durable, powder coated RAL #7035 finish.
- Adjustable strike bracket with u-bolt fastener
- Anti-Theft manipulation device
- 24" tall latch protector
- Specified, pre-drilled trim box
- 24", 2-piece panic shield adjustable to suit 30" - 54" wide gates

### Panic Trim

The selected Codelock in it's box containing installation, operating / programming instructions and fastening bolts, **or**, key cylinder box for keyed gates.





### CL600 Mechanical

Heavy duty locks with on-door code changes and key override. Marine grade finish available.



### CL5200 Electronic

Heavy duty electronic lock with tubular latch, full size lever handles and key override. Up to 80 User Codes.



### CL5500 Smart Lock

Heavy duty smart lock. Combines smart technology with traditional keypad and RFID access credentials.

## Applications

Codelocks Mechanical, Electronic and Smart Locks are suitable for installation to 4 different types of fencing. Some locks will be better suited to specific applications and fence types than others. To discuss your application and find the right lock for you, contact us.



Chain link



Wood



Vinyl



Ornamental steel

### i Key Cylinder Box

Available for keyed gates. RAL #7035 powder coated.

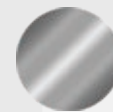

Stainless Steel finish

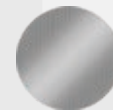

Brushed Steel finish

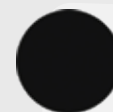

Marine Grade finish, specially enhanced to withstand harsh outdoor environments and coastal applications



CODELOCKS







## Marine by Codelocks, locks you can rely on.

The Marine by Codelocks range of mechanical locks feature a specially enhanced, salt spray tested\* black marine grade finish to better withstand harsh outdoor environments and coastal applications. They're the same convenient, easy-to-use locks with a tougher exterior.

Following an expansion to the range, it now includes selected locks from the CL200, CL400, CL500 and CL600 mechanical ranges, offering the benefits of key override options as well as lever and ball knob handles. Reliable and durable, these locks are ideal for external applications; outbuildings, construction sites, marinas and homes by the water.

\*Up to 1000 hours, tested in-house by Codelocks Ltd.



CL200  
Mechanical



CL400  
Mechanical



CL500  
Mechanical



CL600  
Mechanical



**PINGuard™**  
by Codelocks



Weather  
protection



Code  
protection



Easy to  
install

# Protect your code. Protect your lock.

PINGuard™ by Codelocks offer flexible, high grade polymer weather shields with additional code protection privacy. Suitable for CL200, CL500 and CL600 mechanicals. Polycarbonate weather shields, included in the kit, are required upon external installation of the CL5200 and CL5500 electronic locks.

Add PINGuard™ by Codelocks to external and internal doors to significantly reduce the effects of water ingress and protect the PINs from view. The added weather protection will extend the life of your lock by protecting the finish, the keypad and overall appearance of your Codelocks product.





## Clean by Codelocks

An optional coating which can be applied to any of our Codelocks products. The clear, permanent coating combats SARS-CoV-2 coronavirus (COVID-19) and can reduce bacterial growth by 99.96%\*, providing an additional measure of protection over sanitization.

Clean by Codelocks features an ISO certified\* photocatalytic coating which, when applied to our locks, offers enhanced protection against viruses, bacteria, germs and other environmental toxins. The coating utilizes a process called photocatalytic oxidation, which means that the coating converts harmful bacteria and germs into a non-toxic compound, resulting in a clean and hygienic surface.

Improve your protection against COVID-19 for your staff and visitors by using a Clean by Codelocks lock for your access. During testing\*, the coating has shown to be highly effective at eliminating the SARS-CoV-2 coronavirus (COVID-19) within minutes.

Clean by Codelocks should be used in conjunction with existing cleaning and sanitization processes. The coating is resistant to chemical cleaners and will provide enhanced, active protection creating a self-sanitizing surface that helps to reduce build-up of volatile organic compounds (VOCs).

The Clean by Codelocks coating has been evaluated for its resistance against humidity, artificial weathering (through UV exposure) and household chemicals. The coating was applied to Codelocks Smart Locks and, following rigorous testing\*\*, has proven to be:

- ✓ Water resistant in 100% relative humidity
- ✓ Weatherproof against UV Exposure
- ✓ Resistant against household chemicals

### KEY FEATURES

- ✓ Tested against SARS-CoV-2 coronavirus (COVID-19)\*
- ✓ ISO certified\*
- ✓ Clear photocatalytic coating
- ✓ Additional protection over sanitization
- ✓ Reduces bacterial growth by 99.6%\*
- ✓ Resistant to chemical cleaners
- ✓ Enhanced protection against viruses & toxins

\*Clean by Codelocks is a brand name operated by Codelocks Inc. to describe products that have been treated with the LumaClean™ Multipurpose Photocatalytic Coating manufactured by USA Nanocoat "the Manufacturer". All test results, certifications and claims are those applied for or of the Manufacturer. Clean by Codelocks should be not be considered a replacement for an overall cleaning and disinfection strategy. No claim is made or implied that Clean by Codelocks provides infallible protection against agents that may be harmful in part or whole to humans or animals.

\*\*Independently tested on Codelocks Smart Locks sprayed with LumaClean™. Testing included 24 hours of being immersed within household chemicals, 1000 hours of humidity and 1000 hours of UV exposure within a laboratory environment.

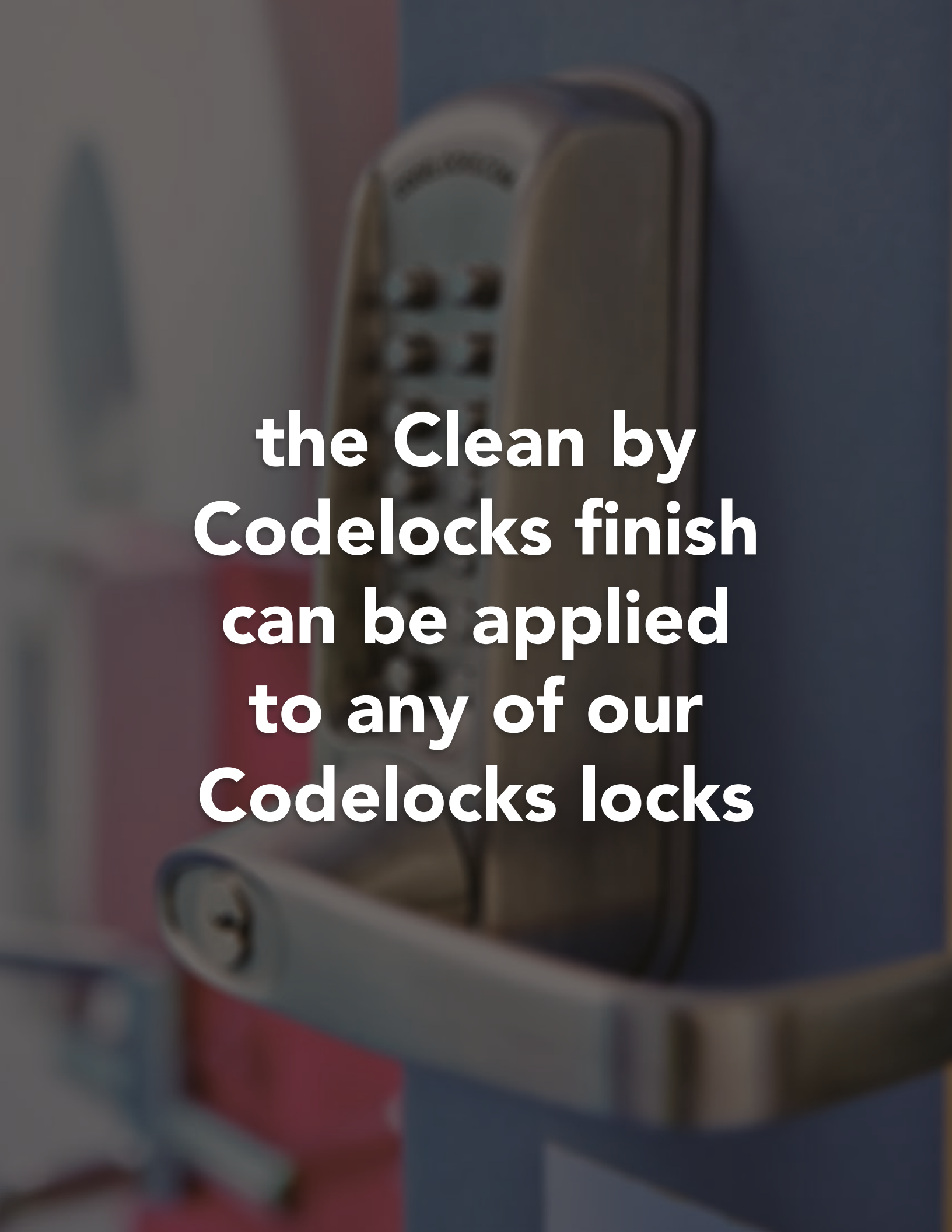

**the Clean by  
Codelocks finish  
can be applied  
to any of our  
Codelocks locks**



# CODELOCKS

control + convenience

## CODELOCKS INC (UNITED STATES)



[sales@codelocks.us](mailto:sales@codelocks.us)  
[www.codelocks.us](http://www.codelocks.us)



**T** +1 714 979 2900  
**F** +1 714 979 2902

