



Prime-GUARD

Monitored Thru-Beam Photo Eye

INSTALLATION INSTRUCTIONS

Model #PG



IMPORTANT: READ AND UNDERSTAND ALL INSTRUCTIONS BEFORE BEGINNING INSTALLATION

The Prime-Guard photo optic system consists of one battery or wired infrared emitter and one infrared receiver housed in separate units. The units are intended to be positioned in such a way that an obstruction in a hazardous area will interrupt the infrared light beam. An interruption of the beam will signal controls to stop or stop and reverse motion.

1-Models

EMITTER

- PG-EM-50: 50' battery
- PG-EM-100: 100' battery
- PG-EM-W: 100' wired (external power)

RECEIVER

- PG-RX-P: 2-wire or 4-wire pulsed output
- PG-RX-R: 10K, N.C., N.O. output

2-Parts List

Check to make sure all parts are included (units packaged separately):

RX UNITS

- Either (1) RX-R or (1) RX-P
- (1) Bracket
- (2) Hex head mounting screws
- (2) Flat washers
- (2) Stop nuts
- (1) Strain relief

BATTERY EM UNITS

- Either (1) EM-50 or (1) EM-100
- (2) Hex head mounting screws
- (2) Flat washers
- (2) Stop nuts
- (2) AA lithium batteries

To avoid risk of electrocution, turn off and disconnect electrical power to the motor before wiring.

3-Emitter Power & Mounting Bracket

1. Remove the bottom cap from the base by pressing in the tabs with your fingers and pulling the cap away from the unit.
2. To open the unit, remove the two (2) Phillips screws accessible from the bottom of the base.
3. Slide the base away from the case to expose the PCB.
4. Connect power:
 - Battery: Insert AA lithium batteries noting the polarity. LED blinks.
 - Wired: Connect the two power leads to TB1.
5. If necessary, reconfigure the mounting brackets to the unit by sliding the head of the provided hex-head bolts into the appropriate channel of the case and loosely tighten with the provided nuts. This will allow easier adjustment during the alignment phase.
6. Re-insert the base into the case and re-tighten the screws.
7. Snap in the bottom cap.
8. Select a stable mounting location with a clear line of site to detect obstructions, where the light beam could not be obstructed by plants, leaves, etc.
9. Before mounting the emitter, proceed with wiring the receiver.

4-Receiver Wiring Connections & Mounting Bracket

1. Remove the bottom cap from the base by pressing in the tabs with your fingers and pulling the cap away from the unit.
2. To open the unit, remove the two (2) phillips screws accessible from the bottom of the base.
3. Slide the base away from the case to expose the PCB. Do not touch the lens.
4. Follow the simple wiring below (Table 1 & Figure 1) to connect the receiver unit to the operator.
5. Re-insert the base into the case and re-tighten the screws.
6. Snap on the bottom cap.

TABLE 1. PRIME-GUARD RECEIVER WIRING TABLE

Safety Device Output	TB1 Connects to: 12/24V	TB2	TB3	J2	J3	J4
2-Wire Pulsed	Not used	Connect to operator monitored input terminals.				
4-Wire Pulsed	Yes	Connect to operator monitored input terminals.			Cut	Cut
N.C.	Yes		Use N.C. & Common and then connect to operator monitored input terminals			
10K	Yes		Use 10K & Common and then connect to operator monitored input terminals			
N.O. (non-monitored)	Yes		Use N.O. & Common and then connect to operator non-monitored input terminals	Cut		

Note: RX-P is factory wired for 2-wire pulsed output. For 4-wire pulsed output, clip the jumper wires located at J3 and J4.

Note: RX-R is factory wired for 10K output. For normally open (N.O.) operation, clip the jumper wire located at J2 on the PCB.

FIGURE 1. PCB LAYOUT

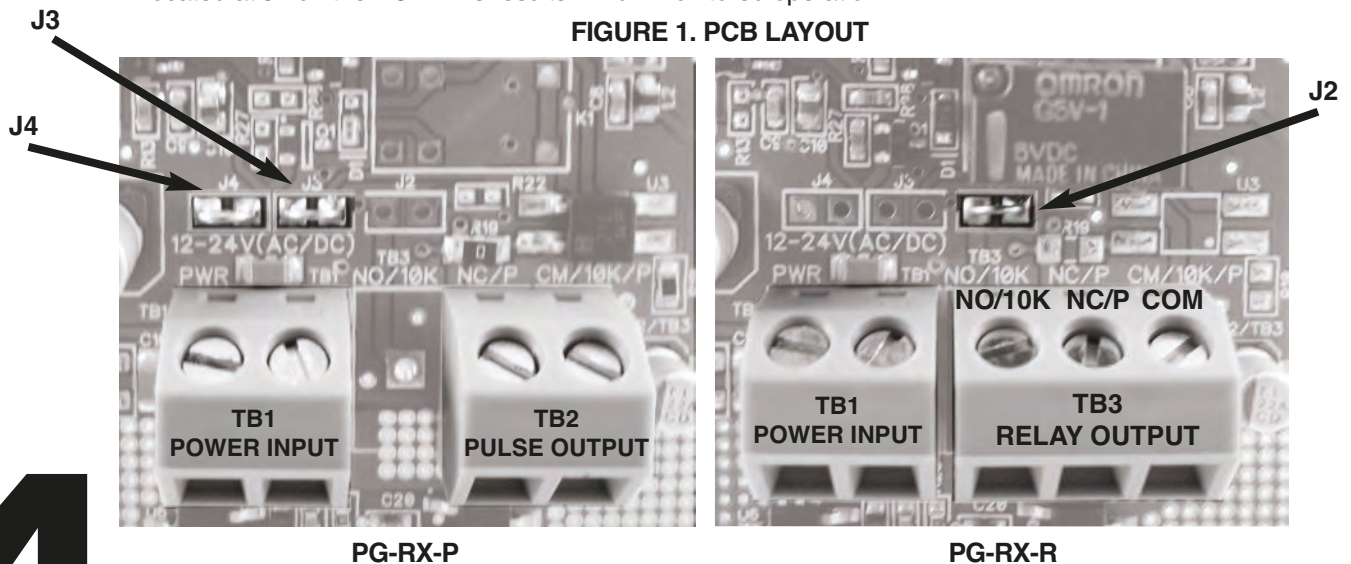

5-Mounting & Alignment

1. Select a stable mounting location with a clear line of site to detect obstructions, where the light beam could not be obstructed by plants, leaves, etc.
2. Determine horizontal or vertical bracket mounting direction. For ease of alignment, both emitter and receiver should be mounted loosely for now.
3. Aim the emitter and receiver unit toward each other.

Align the RX & EM units by watching the front-mounted green alignment LED below the hood. It will be ON solid when the units are properly aligned. The alignment LED flickers when alignment is close but not good enough. Adjust the alignment until the LED is ON solid.

4. If you have trouble getting the units aligned, try raising or lowering either the receiver or the emitter unit. Also, try rotating the units back and forth. Make sure the distance spanned is not greater than the listed range.
5. Keep in mind, when installing multiple sets of photo eyes on a single door, or installing a single set of photo-eyes on multiple adjacent doors, it is advisable to alternate receiver and emitter locations, so as to eliminate any potential for cross-talk.

6-Technical Specifications

Detection Technology	Infrared through-beam (850 nm)
Infrared Beam Range	50' standard, 100' optional
Operating Temperature	-40°F to 185°F (-40°C to 85°C)
Power Supply (Em battery versions)	2 x 1.5V, AA lithium batteries
Power Supply (Rx) & (Em)	7-30 VAC (50/60 Hz) or 10-42 VDC, 100 mA
Low Battery Indicator	Top-mounted: green (RX-R)/blue (RX-P) flashing LED
Fault Indicator	Top-mounted red LED
Alignment Indicator	Front-mounted green solid LED
Enclosure	NEMA 4
Certification	UL 325 (January 2016)

7-Troubleshooting Tips

EM Normal operation: Top LED flashes every 15 seconds (battery) or ON solid (wired)

RX Normal operation: Top green LED or blue LED & front green LEDs ON solid, red LED is OFF

Em Model	Em LED	Status	Diagnosis	Solution
50' Battery	Green	Flashes every 15 seconds	Good batteries	Normal operation
		Off	Low or dead batteries	Replace batteries
100' Battery	Orange	Flashes every 15 seconds	Good batteries	Normal operation
		Off	Low or dead batteries	Replace batteries
100' Wired	Orange	On solid	Good power	Normal operation
		Off	Bad power	Check wires (loose/broken)



Rx LED	Status	Diagnosis	Solution
Top Green or Blue LED	On	EM/RX power is ok	Normal operation
	Off	No RX Power or dead batteries or low batteries and fault*	Check wires (loose/broken), or replace EM batteries, or clear fault* & replace EM batteries
	Flashing	Low batteries and no fault*	Replace EM batteries
Top Red LED	On	Fault*	Remove obstruction and/or re-align units
	Off	Normal operation	
Front Green LED	On Solid	RX & EM are aligned (good beam)	Normal operation
	Off	RX & EM are not aligned or fault* (bad beam)	Align the RX & EM units and/or remove obstruction
	Flickers	RX & EM are partially aligned	Align the RX & EM units better

*Note: Fault is a blocked beam by an obstruction or a misalignment of the RX/EM pair.

8-Care & Maintenance

- Use only AA size lithium batteries.
- Use only a clean lint-free cotton or nylon cloth, or a cotton swab, to clean the lenses or outer protective film. Do not use any cleaning fluids on these surfaces.
- The outer surfaces of the units, except for those mentioned above, can be wiped with a cloth dampened with water. Wring out the cloth to remove excess water.
- Do not submerge the unit in any liquid.

9-Warranty

Miller Edge, Inc. will replace or repair within 2-years of shipment from factory. Warranty is void where evidence of misuse or abuse is present as determined solely by our authorized factory representative. Batteries are not covered under this warranty.

