

ALL DIMENSIONS IN MILLIMETRES
REMOVE ALL SHARP EDGES

THIRD ANGLE PROJECTION
DO NOT SCALE DRAWING

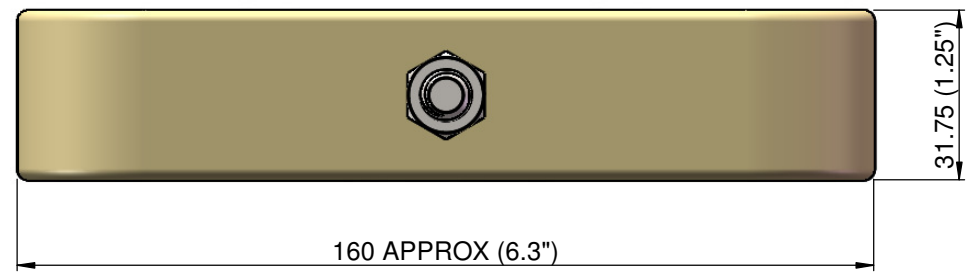
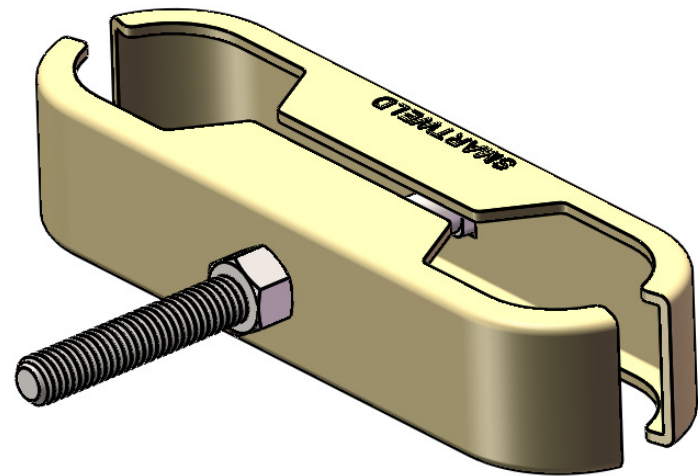
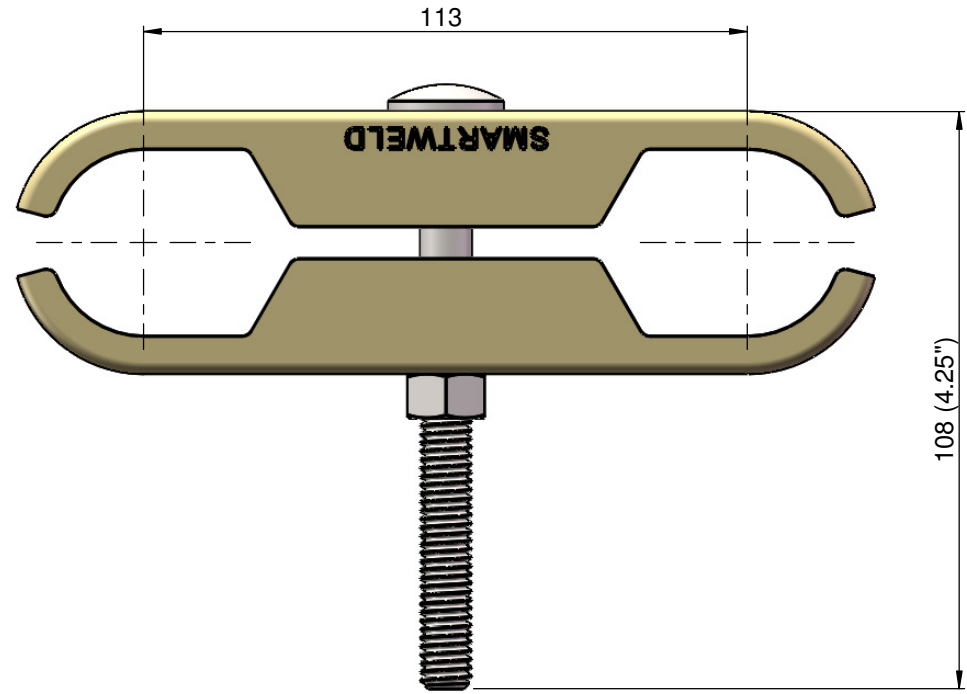

0	28/7/22	ISSUED FOR MANUFACTURE	GC		
P2	19/7/22	ISSUED FOR APPROVAL	GC		
REV	DATE	DESCRIPTION	DRN	CHKD	APPR

TOLERANCES - UNLESS STATED OTHERWISE		TITLE: EXTENSION PANEL COUPLER HD (GRIPPER)					
FABRICATION	UP TO 300mm	+/- 1mm	DRAWN	NAME	SIGNATURE	DATE	MATERIAL:
	UP TO 1000mm	+/- 2mm		G. CRICK		18/7/22	
	1001mm & ABOVE	+/- 3mm	CHK'D			FINISH: ELECTRO GALVANISED COLOUR: GOLD	
	ANGULAR	+/- 1°					
MACHINING	+/- 0.2mm						
TUBE GAUGE	T<1.5 = +/- 0.15mm						
	T>1.5 = +/- 0.1T or +/- 0.35mm WHICHEVER IS THE SMALLER						
SHEET GAUGE	+/- 10%						
WEIGHT	+/- 10% (DUE TO MATERIAL PROPERTIES & TOLERANCES)						



Drw / Stockcode No.	Revision
08551340	0

THE COMPANY RETAIN THE RIGHT TO PERIODICALLY ALTER INFORMATION WITHIN THIS DRAWING SHEET AND WILL ATTEMPT TO NOTIFY ALL PARTIES CONCERNED OF ANY CHANGES AND THE INFORMATION ON THIS SHEET SHOULD NOT BE REPRODUCED WITHOUT THEIR WRITTEN CONSENT.