

ALL DIMENSIONS IN MILLIMETRES  
REMOVE ALL SHARP EDGES

THIRD ANGLE PROJECTION  
DO NOT SCALE DRAWING

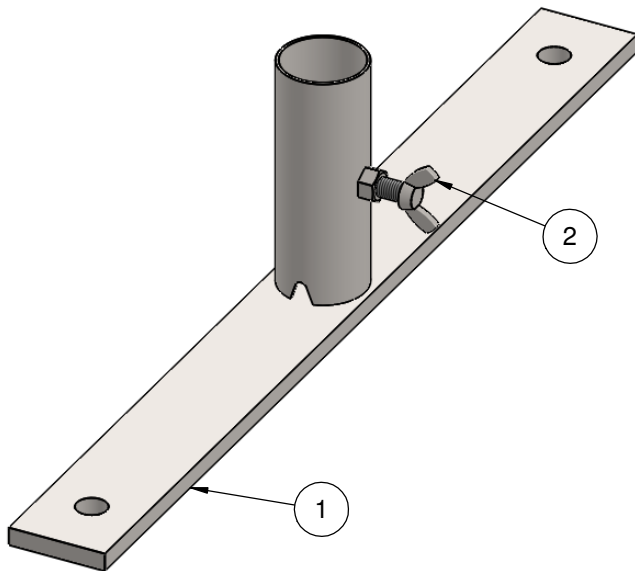
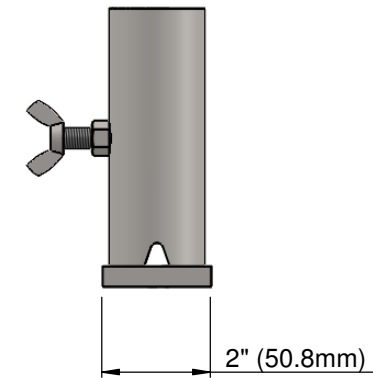
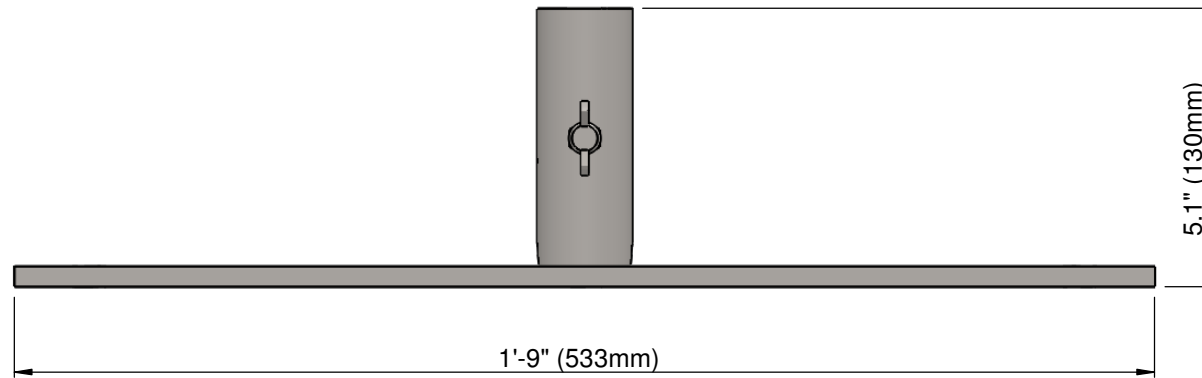

1	15/5/20	ISSUED FOR MANUFACTURE	GC	.	.
0	30/4/20	ISSUED FOR MANUFACTURE	GC	.	.
REV	DATE	DESCRIPTION	DRN	CHKD	APPR

ITEM No.	PART No.	DESCRIPTION	QTY
1	01062201-2-1	FOOT FABRICATION	1
2	01062201-2-2	3/8" UNC WINGED STUD	1

TOLERANCES - UNLESS STATED OTHERWISE		
FABRICATION	UP TO 300mm	+/- 1mm
	UP TO 1000mm	+/- 2mm
	1001mm & ABOVE	+/- 3mm
	ANGULAR	+/- 1°
MACHINING	+/- 0.2mm	
GAUGE	+/- 10%	
WEIGHT	+/- 10% (DUE TO MATERIAL PROPERTIES & TOLERANCES)	

TITLE: FLAT FOOT			
NAME	SIGNATURE	DATE	MATERIAL:
G. CRICK		30/4/20	CARBON STEEL GRADE S235
FINISH: HOT DIPPED GALVANISED			



Drw / Stockcode No.	Revision
01062201-2	1

THE COMPANY RETAIN THE RIGHT TO PERIODICALLY ALTER INFORMATION WITHIN THIS DRAWING SHEET AND WILL ATTEMPT TO NOTIFY ALL PARTIES CONCERNED OF ANY CHANGES AND THE INFORMATION ON THIS SHEET SHOULD NOT BE REPRODUCED WITHOUT THEIR WRITTEN CONSENT.