



Product & Packaging Specs

34" 2-3/8 Dia Post Anchor (ISW-850)

Item #: 30040

ITEM NO.	QTY.	PART NUMBER	DESCRIPTION
1	1	30040-11	Assembly, Base Anchor
2	1	30040-13	Base, Post Anchor Steel
3	1	30040-14	Cap, Post Anchor Steel

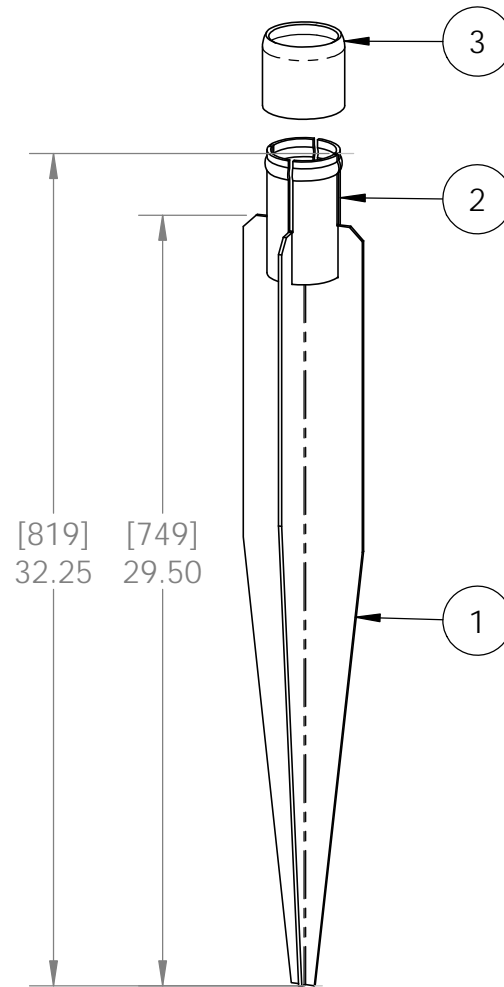
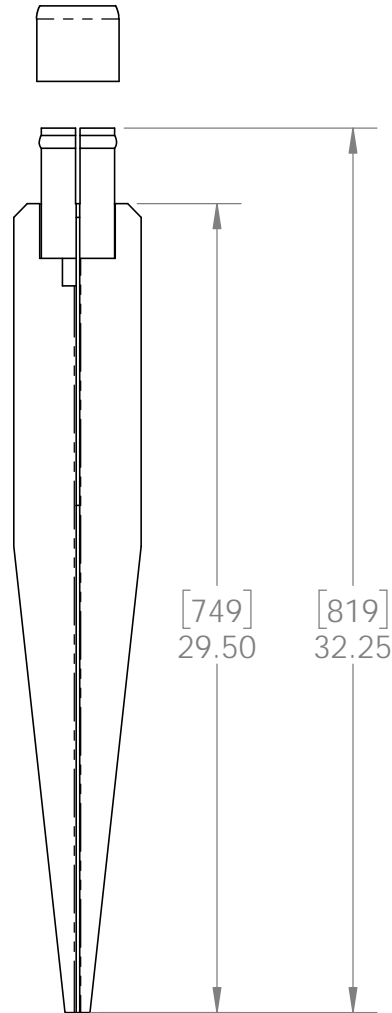
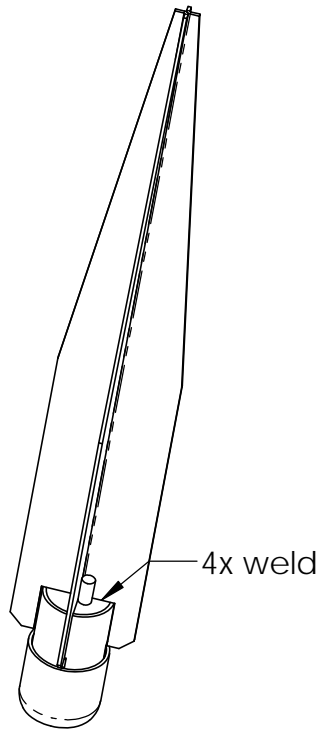

Weight: 9.34 LBS
 Scale: 1:7
 Last updated: 10/14/2016

30040-10



Product & Packaging Specs

34" 2-3/8 Dia Post Anchor (ISW-850)

Item #: 30040

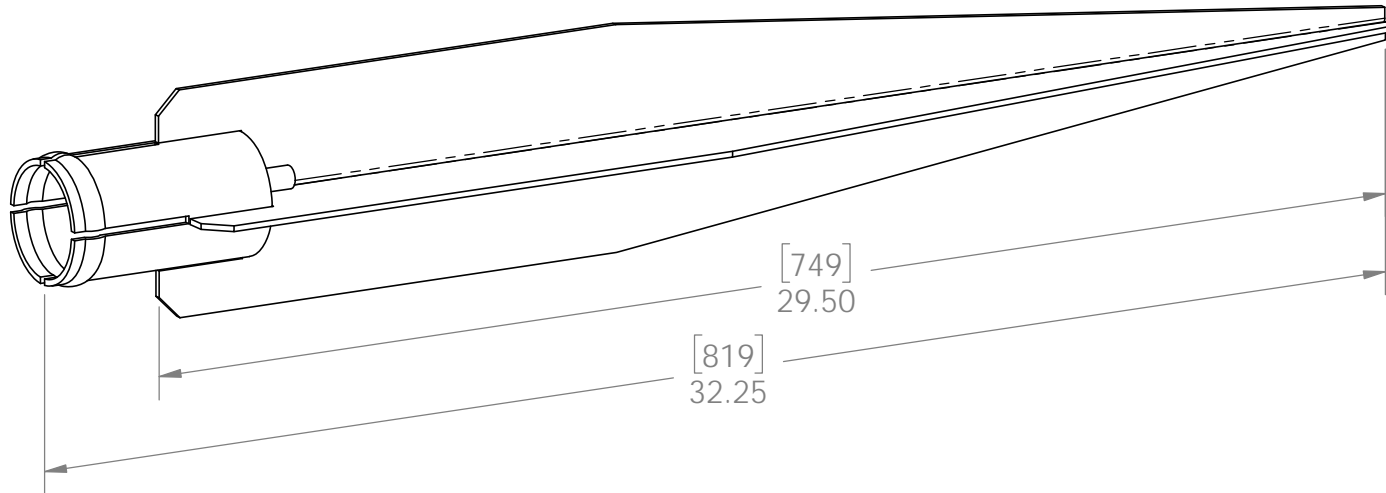

Weight: 9.34 LBS
Scale: 1:4
Last updated: 10/14/2016

30040-10

OZ-POST

instant post holes

OZCO BUILDING PRODUCTS ■■■

Product & Packaging Specs

34" 2-3/8 Dia Post Anchor (ISW-850)

Item #: 30040

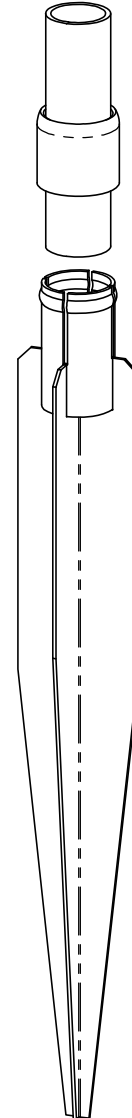
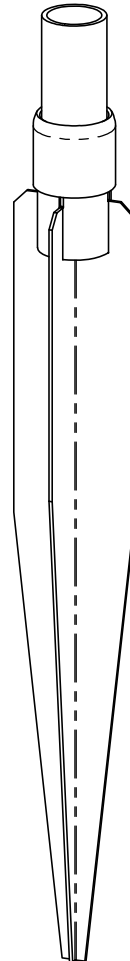
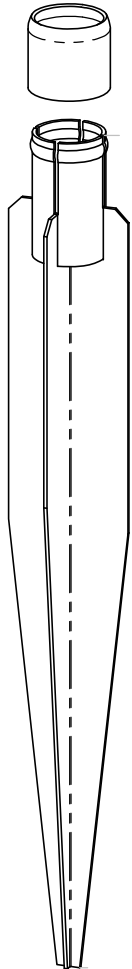

Weight: 9.34 LBS
Scale: 1:7
Last updated: 10/14/2016

30040-10



instant post holes

OZCO BUILDING PRODUCTS ■■■

Product & Packaging Specs

34" 2-3/8 Dia Post Anchor (ISW-850)

Item #: Typical Installation

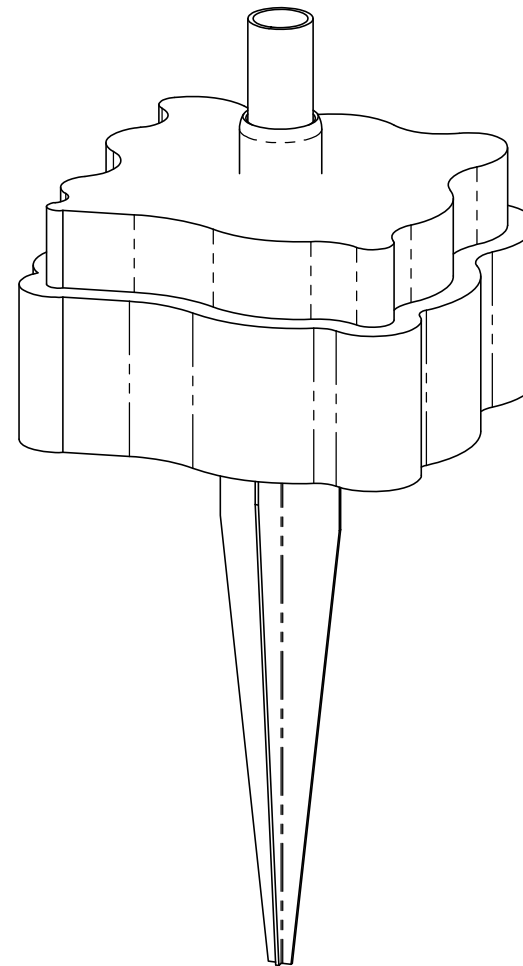
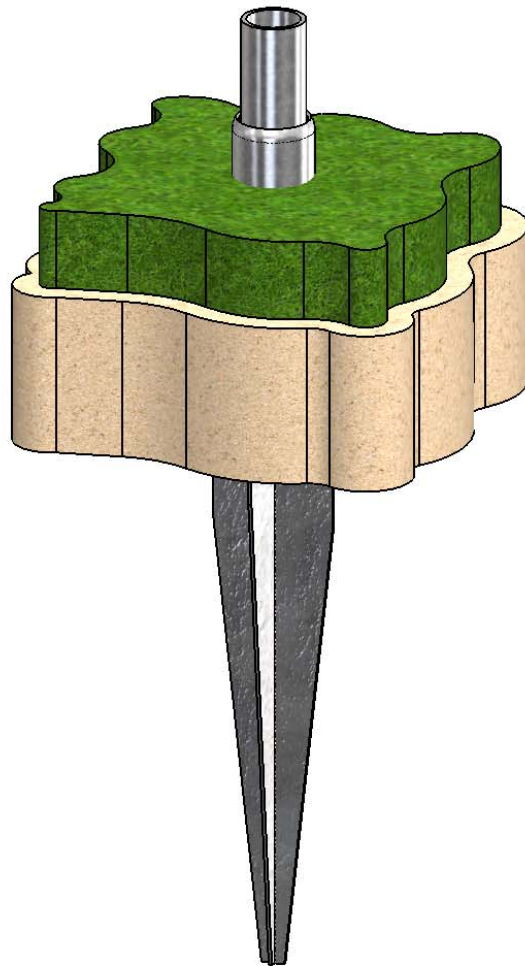

Weight: 9.34 LBS
Scale: 1:7
Last updated: 10/14/2016

30040-10



Product & Packaging Specs

Case, 30041
Item #: Case, 30041

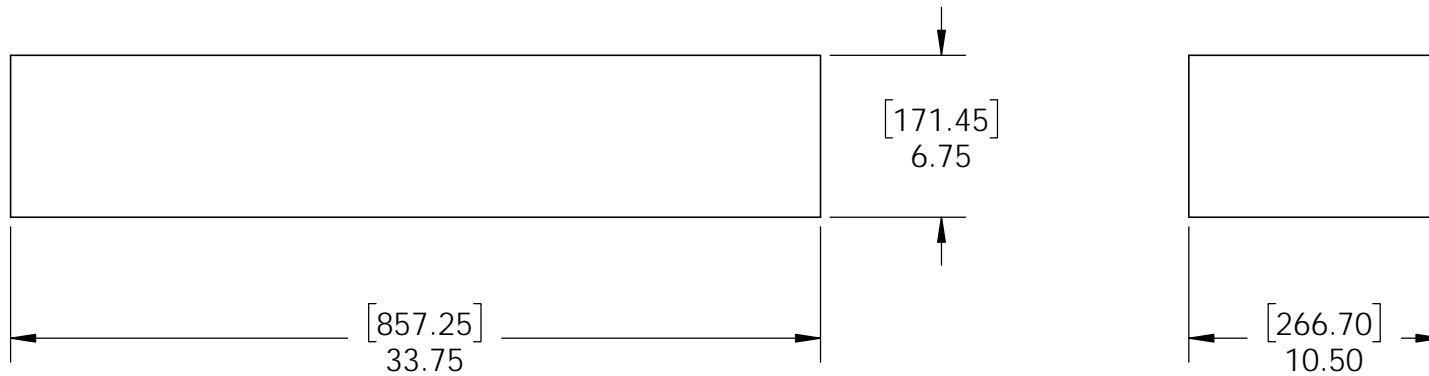
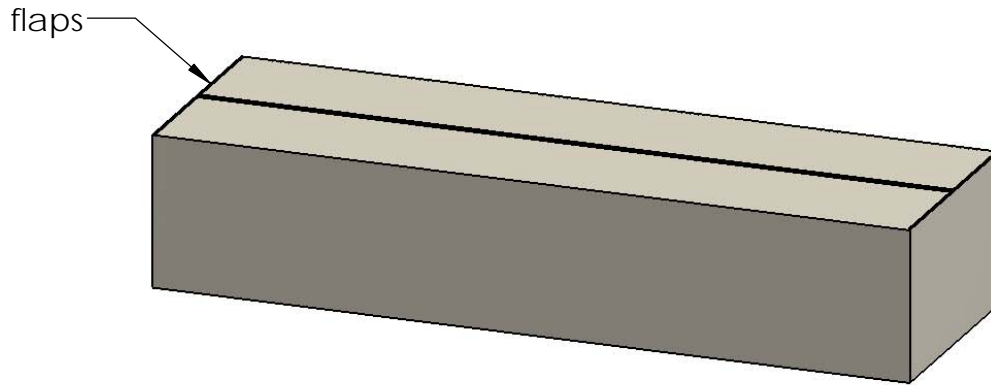

Material: Corrugated Paper
Finish: See artwork
Weight: 0.58 LBS
Scale: 1:8
Last updated: 10/14/2016

30040-10



Product & Packaging Specs

30040 Packing

Item #: Box packing

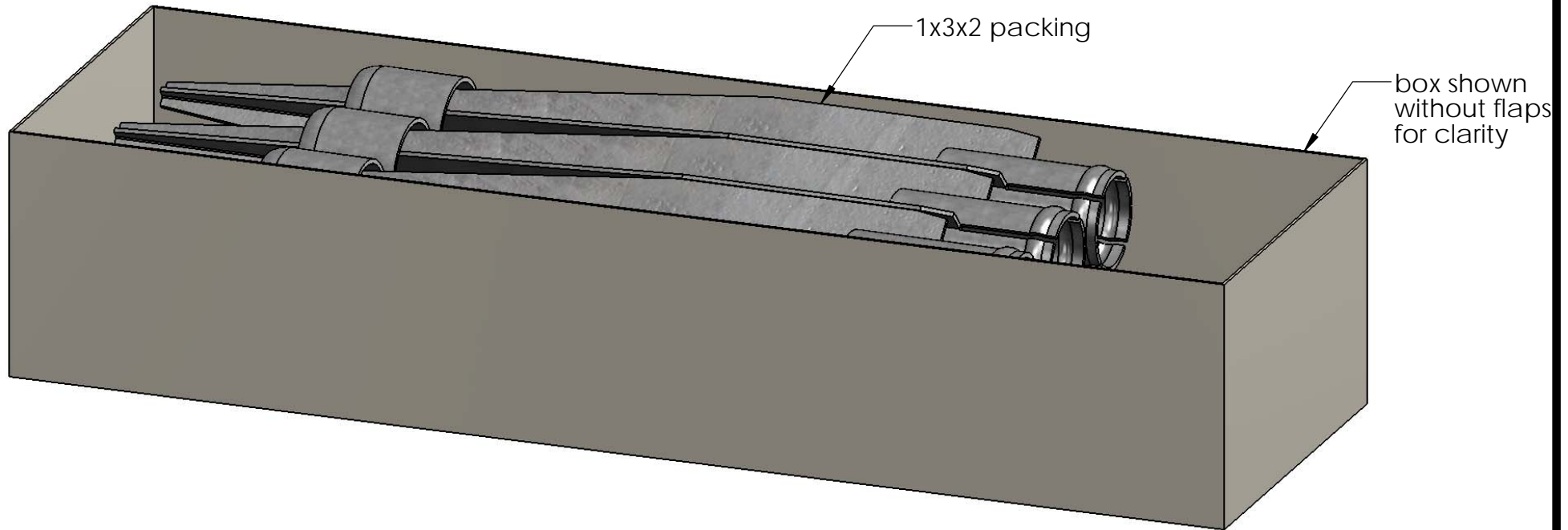

Weight: 42.99 LBS
Scale: 1:4
Last updated: 10/14/2016

30040-10



instant post holes

OZCO BUILDING PRODUCTS

Product & Packaging Specs

30040 Packing

Item #: Pallet packing

Item #: **30040** | **ISW-850**

ISW-850 (2 3/8" Round) Steel

PALLET | **120 pcs**

SKU#: **30042**



Weight: **1179** lbs

LOT# Priority#

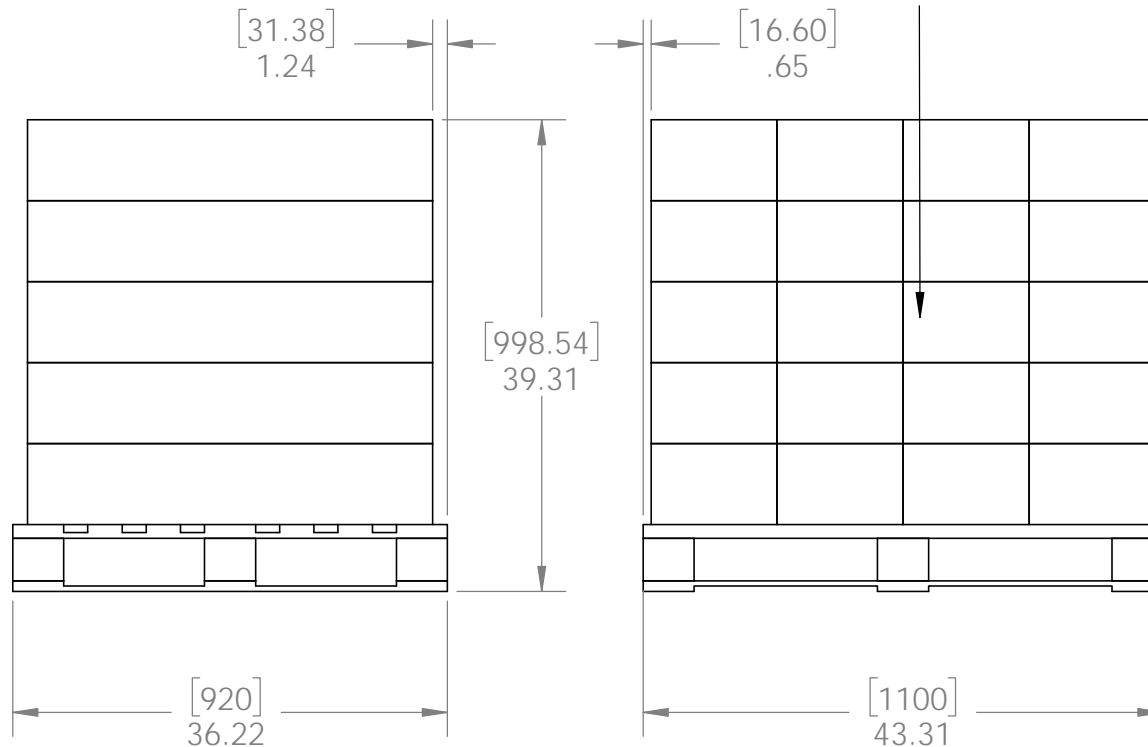

Total number of cases: 20

Total number of pieces:
20x6=120 pieces on pallet

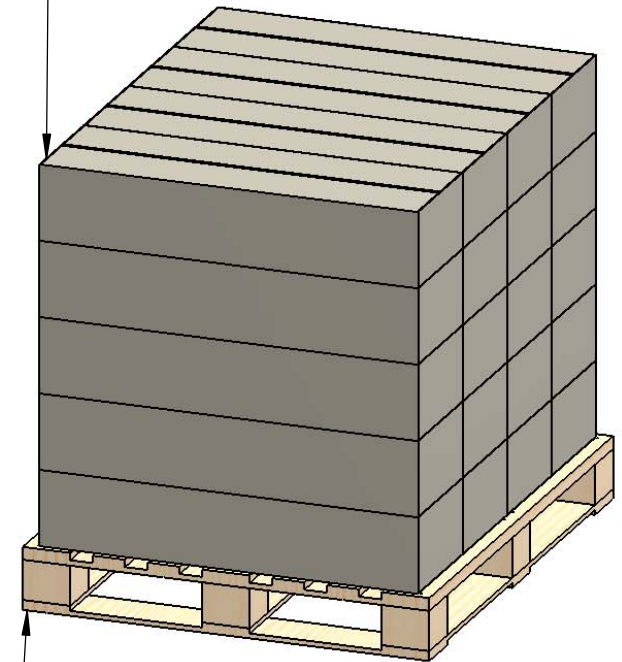

D pallet



additional pallet packing instructions

- plywood on top layer
- strap to pallet
- clear wrap around boxes

Weight: 1179 LBS
Scale: 1:16
Last updated: 10/14/2016

30040-10