

Traditional Mailboxes – 4615 and 4625 Decorative Style Installation Instructions

Made of electro-galvanized steel with a durable powder coated finish, Salsbury 4615 and 4625 traditional decorative mailboxes will provide years of maintenance free service. While the hole locations differ, the mounting method is the same for both the 4615 and 4625 mailboxes.

Mounting Mailbox to a Flat Wall

1. The installation fasteners are not provided due to the variation in wall types to which the mailbox might be mounted. Select fasteners and anchors appropriate for the type of wall.
2. Mounting access is provided by opening the lid.
3. Where possible, it is best to shield the mailbox from direct weather conditions.
4. Contact your local U.S.P.S. office for the required height of the mailbox on the wall.
5. Holding the mailbox aligned horizontally in the mounting position, mark on the wall the position of the 4 mounting holes in the back wall of the mailbox. The 4 dimpled holes are the mounting holes.
6. Attach the mailbox to the wall using the appropriate fasteners.

Attaching Hooks to Mailbox (optional)

Using the four 1/4" long screws (provided), attach the magazine hooks to the mailbox by inserting each hook through the slots at the base of the mailbox.

Attaching Privacy Panel to Mailbox (optional)

1. Place an adhesive backed square on each corner of the privacy panel.
2. Insert the privacy panel through the top opening with the adhesive backed squares towards the front of the mailbox.
3. Center the privacy panel prior to permanently adhering it to the mailbox.

Cleaning

Use a non-abrasive mild cleaning solution and a soft cloth. Do not use harsh chemicals on or around this product.

4615 Traditional Mailbox – Horizontal Style

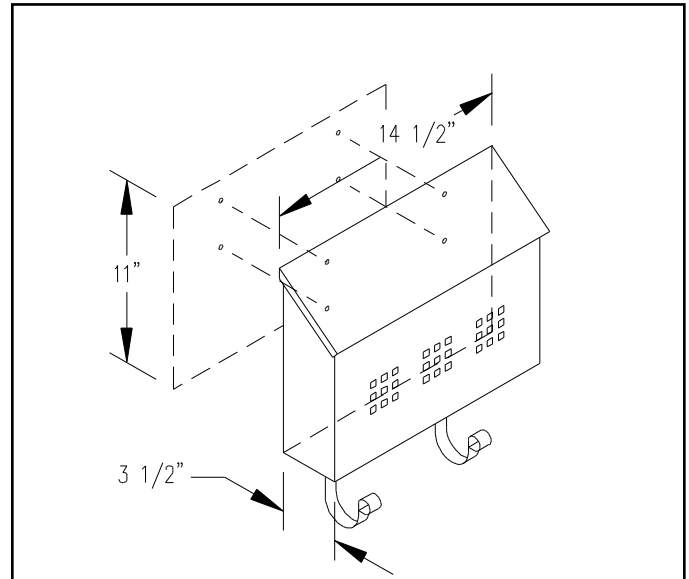

4625 Traditional Mailbox – Vertical Style

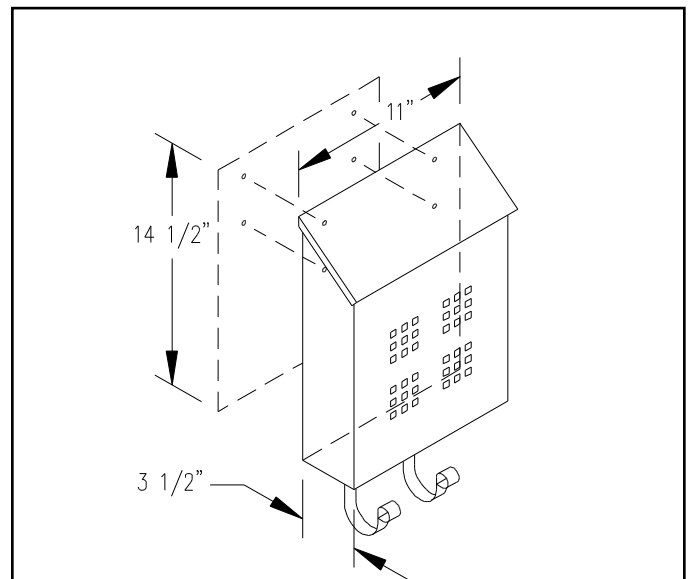

SALSBURY INDUSTRIES

1010 East 62nd Street, Los Angeles, CA 90001-1598
Phone: 1-800-624-5269 Int'l Phone: 323-846-6700
Fax: 1-800-624-5299 Int'l Fax: 323-846-6800
www.mailboxes.com engineering@mailboxes.com