

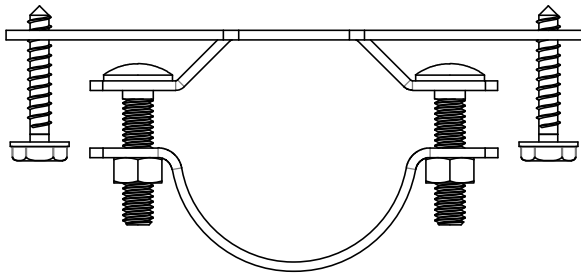

Product & Packaging Specs

2 3/8" Steel to Wood Bracket

Item #: 50110



ITEM NO.	QTY.	PART NUMBER	DESCRIPTION
1	1	50110-12	Bracket, 2-3/8" Steel to Wood Tube
2	2	80112	Bolt, Carriage 5/16-18 x 1.5
3	1	50110-11	Bracket, 2-3/8" Steel to Wood Chassis
4	2	80125	Nut, Hex 5/16-18
5	4	80057	Screw, Lag, #14-10x36mm

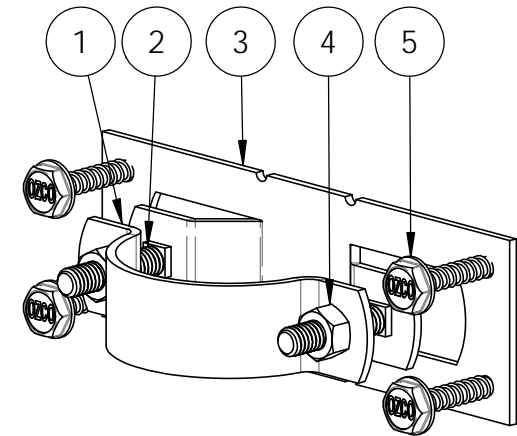
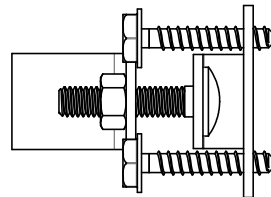
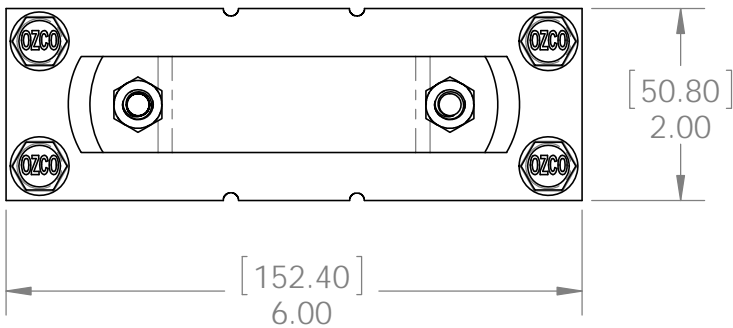

Weight: 8.22 LBS
 Scale: 1:2
 Last updated: 7/13/2015

50110-10





Product & Packaging Specs

2 3/8" Steel to Wood Bracket

Item #: Typical Installation & Basic Assembly

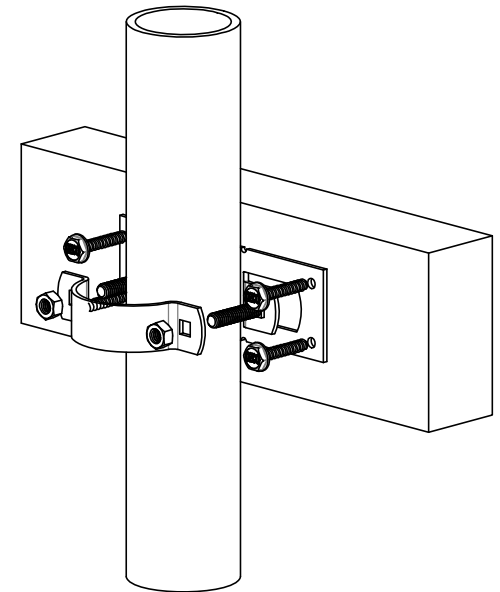
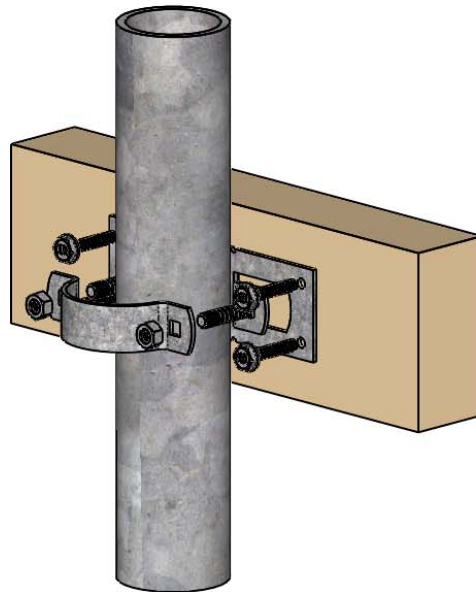
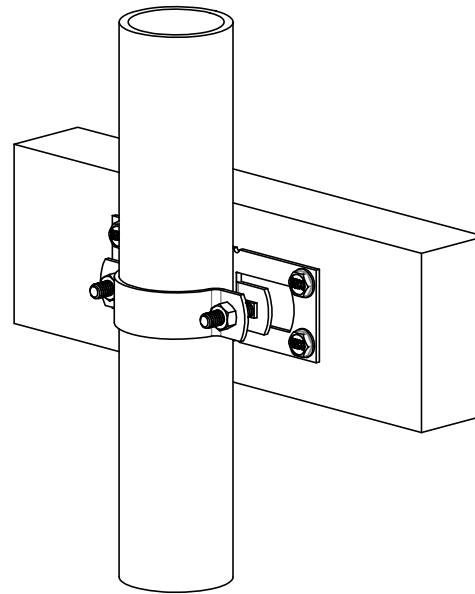
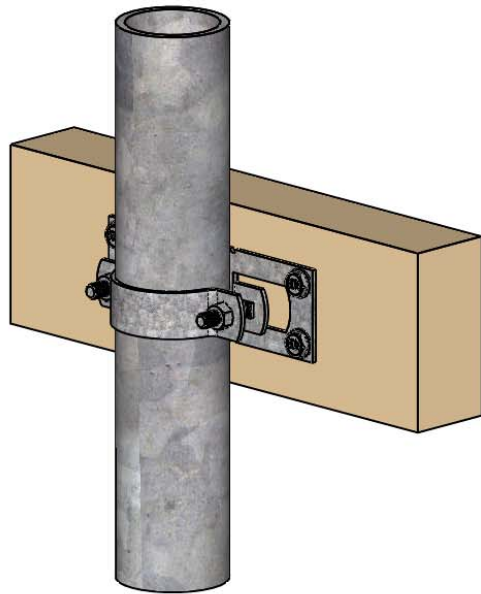

Weight: 8.22 LBS
Scale: 1:1
Last updated: 7/13/2015

50110-10



V1.00 - Installation Instructions effective May 1, 2015 and reflects information that available as of April 10, 2014. This information is updated periodically and should not be relied upon after May 1, 2015. Please visit www.OZCOBP.com to get current information



Product & Packaging Specs

50110 Steel to Wood Bracket Case

Item #: 50110 Case

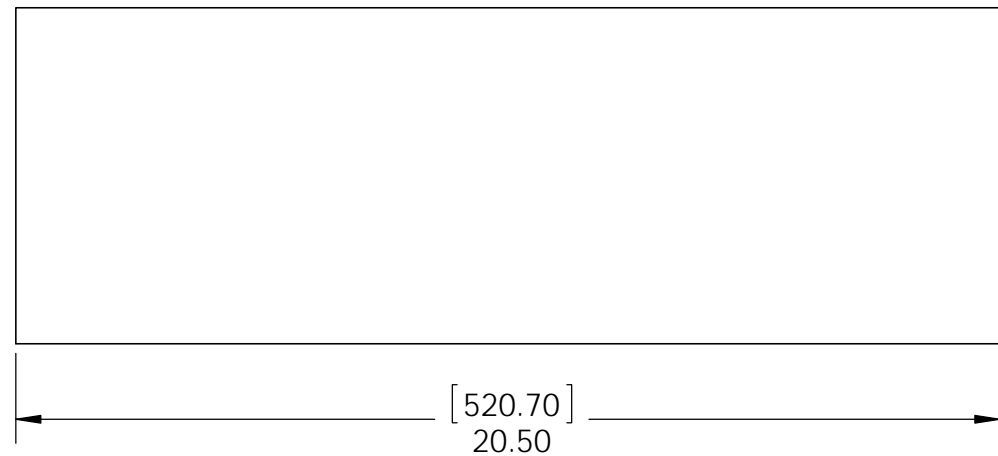
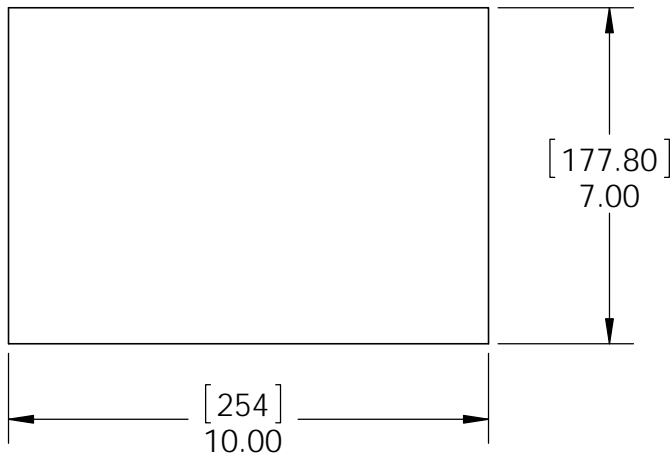

Material: Corrugated Paper
Finish: See artwork
Weight: 1.06 LBS
Scale: 1:4
Last updated: 7/13/2015

50110-10



V1.00 - Installation Instructions effective May 1, 2015 and reflects information that available as of April 10, 2014. This information is updated periodically and should not be relied upon after May 1, 2015. Please visit www.OZCOBP.com to get current information



Product & Packaging Specs

50110 Packing

Item #: Case Packing

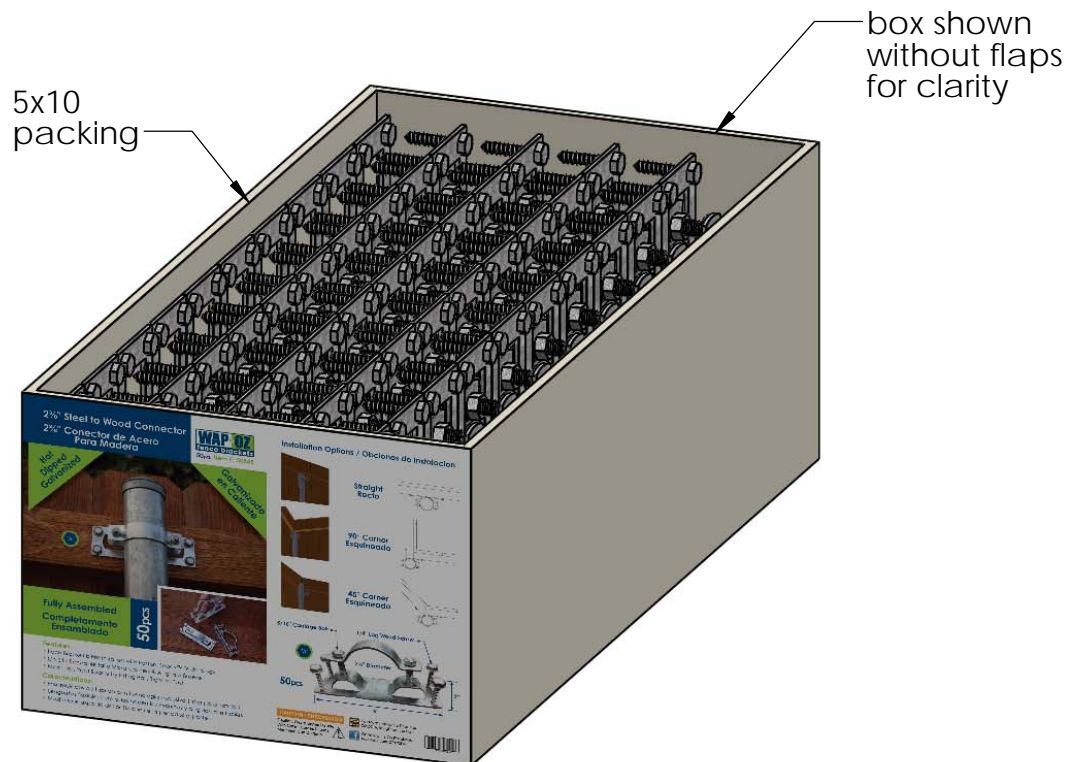

5x10
packing

box shown
without flaps
for clarity

Weight: 31.38 LBS
Scale: 1:4
Last updated: 7/13/2015

50110-10



V1.00 - Installation Instructions effective May 1, 2015 and reflects information that available as of April 10, 2014. This information is updated periodically and should not be relied upon after May 1, 2015. Please visit www.OZCOBP.com to get current information



Product & Packaging Specs

50110 Packing

Item #: Pallet Packing

Item #: **50110** | **WAP-OZ**

WAP-OZ Steel 2 Wood Fence Bracket

PALLET | **1500 pcs**

SKU#: **20112**



Weight: **1055 lbs**

LOT# _____ Priority# _____

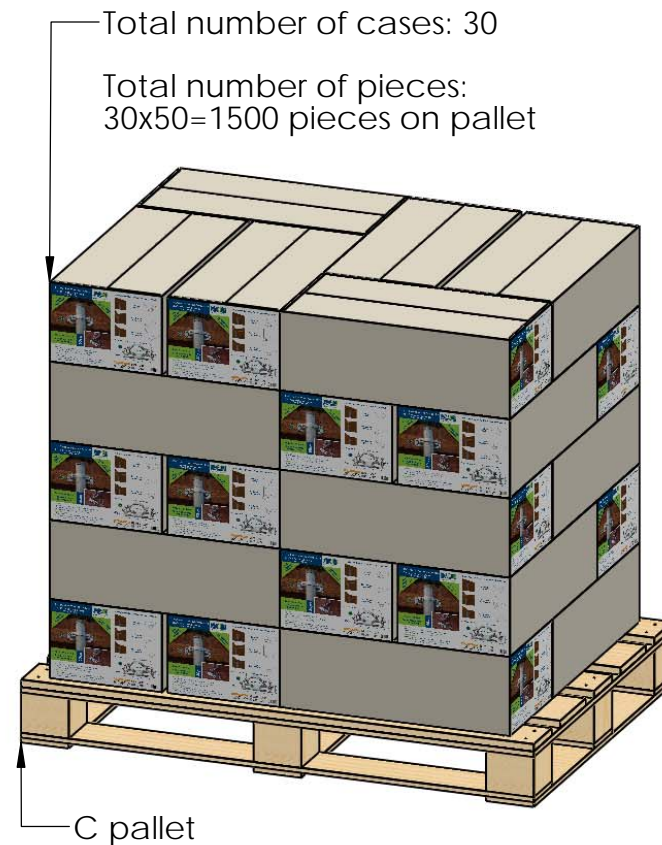
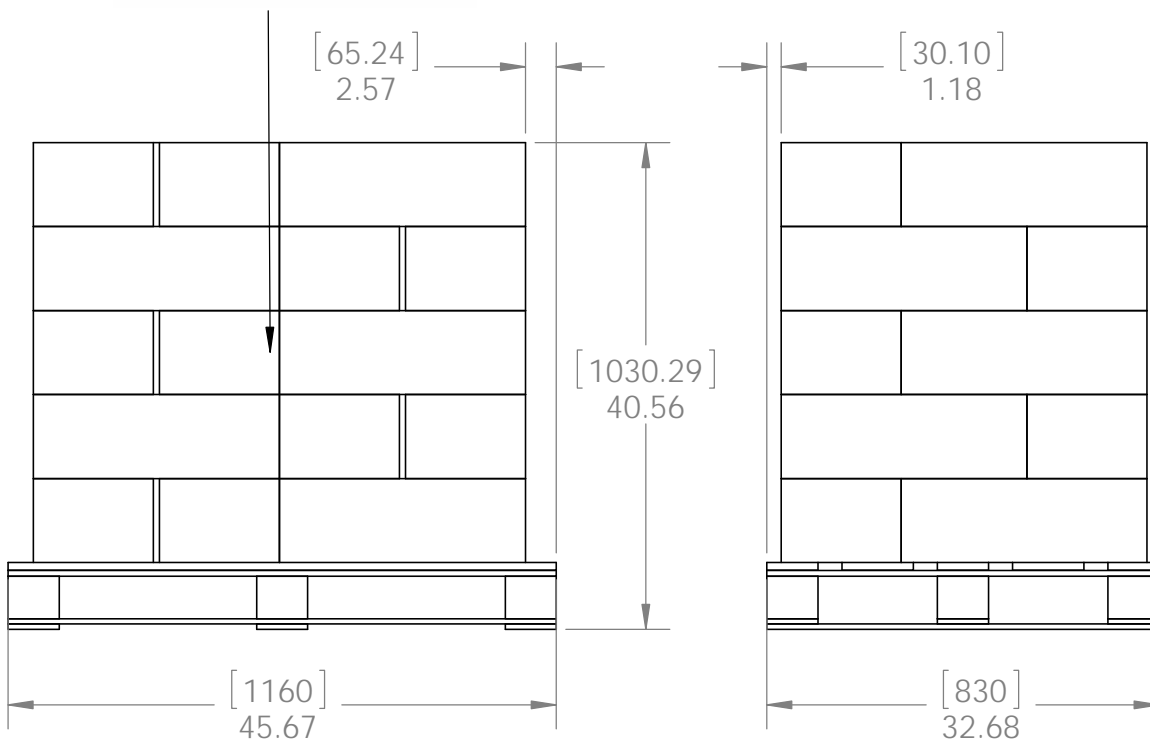

Weight: 1055 LBS
 Scale: 1:16
 Last updated: 7/13/2015

additional pallet packing instructions
 plywood on top layer
 strap to pallet
 clear wrap around boxes



50110-10

V1.00 - Installation Instructions effective May 1, 2015 and reflects information that available as of April 10, 2014. This information is updated periodically and should not be relied upon after May 1, 2015. Please visit www.OZCOBP.com to get current information