

# Product & Packaging Specs

## Assembly, Post Clamp

Item #: 50833

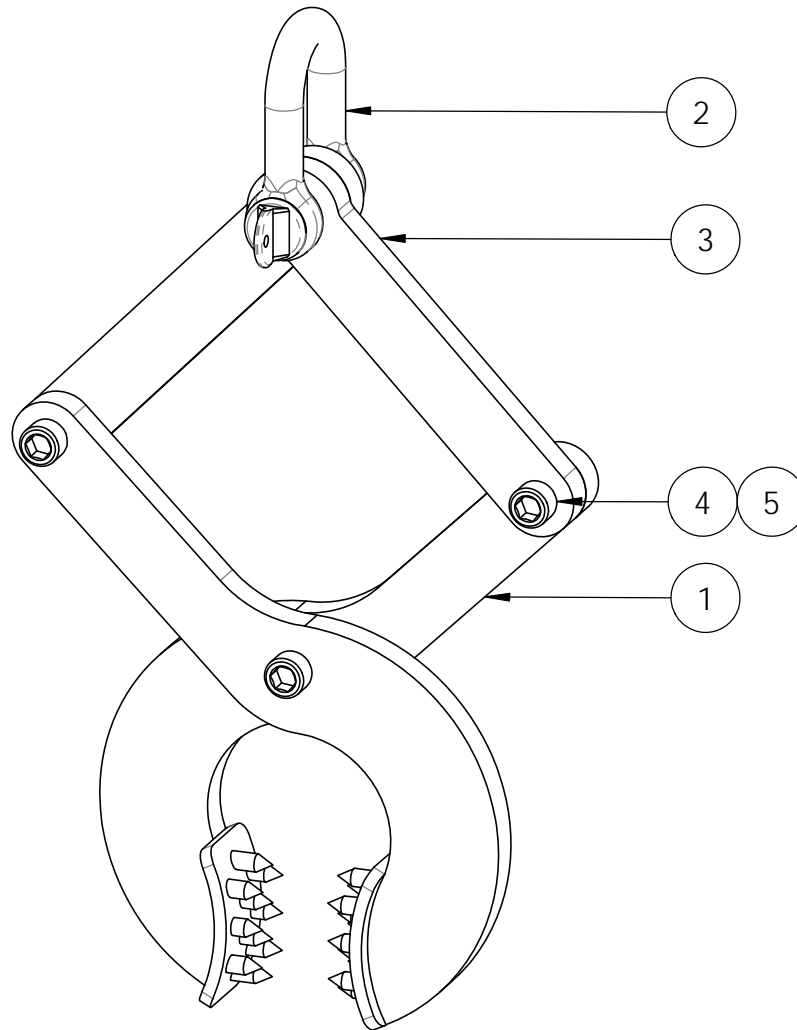

ITEM NO.	QTY.	PART NUMBER	DESCRIPTION
1	2	50833-11	Jaws, Post Lever
2	1	Shackle Straight-D	Shackle, D 2-7/8"
3	2	50833-12	Lever, Post Clamp
4	3	91251A677	Screw, Socket Head Cap, Black 7/16"-14 x 1-5/8"
5	3	95615A180	Nut, Hex Ny-lock 7/16-14

Weight: 10.37 LBS  
 Scale: 1:2  
 Last updated: 7/29/2015

50833

**OZ-PULLER**

post extraction system

**OZCO** BUILDING PRODUCTS

# Product & Packaging Specs

## Assembly, Post Clamp

Item #: 50833

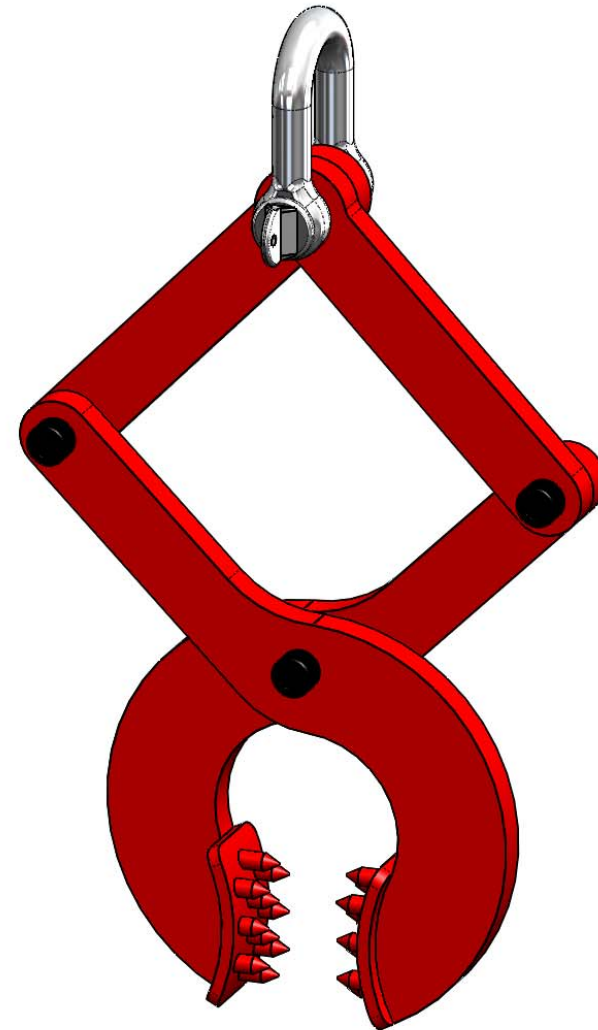
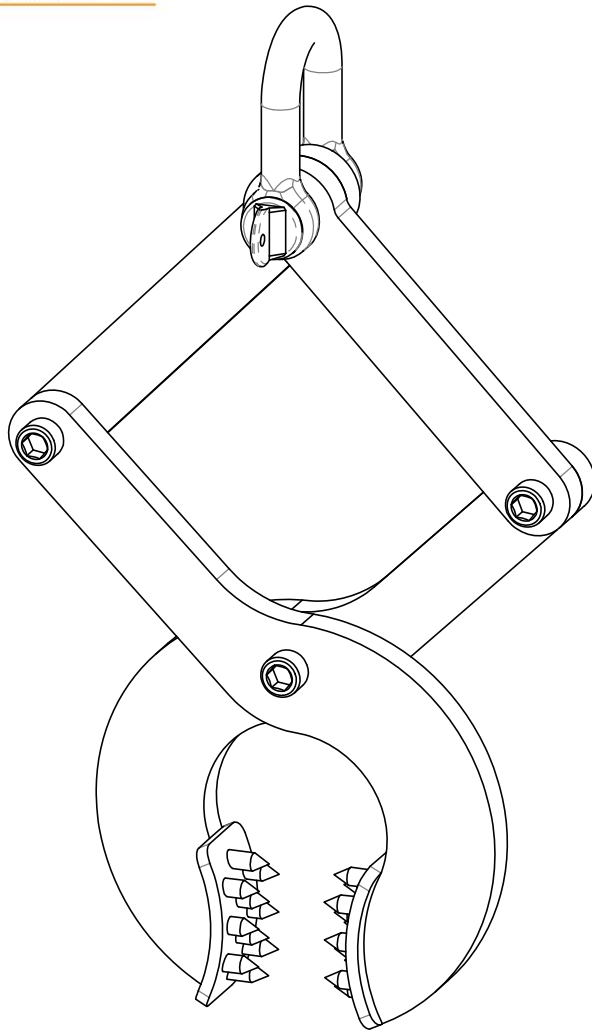

Weight: 10.37 LBS  
Scale: 1:3  
Last updated: 7/29/2015

**50833**

V1.00 - Installation Instructions effective May 1, 2015 and reflects information that available as of April 10, 2014. This information is updated periodically and should not be relied upon after May 1, 2015. Please visit [www.OZCOBP.com](http://www.OZCOBP.com) to get current information



# Product & Packaging Specs

Box, 50833

Item #: Box

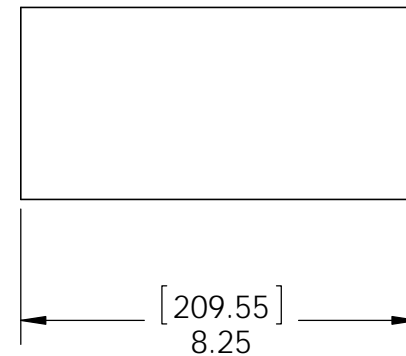
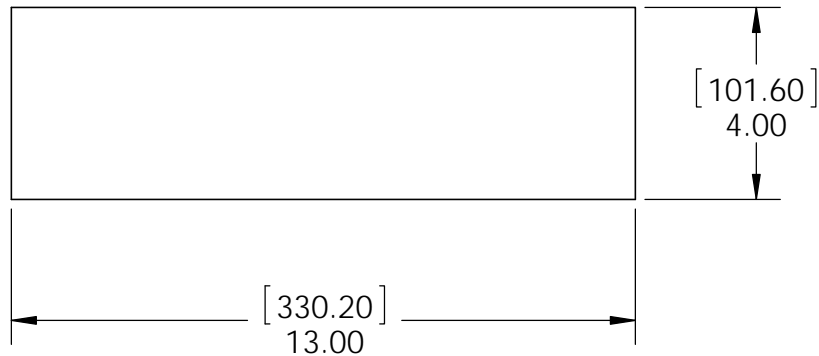
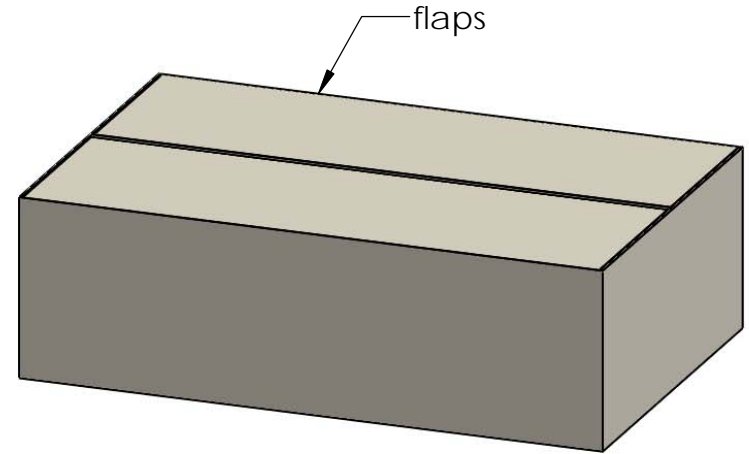

Material: Corrugated Paper  
 Finish: See artwork  
 Weight: 0.09 LBS  
 Scale: 1:4  
 Last updated: 7/29/2015

50833

**OZ-PULLER**

post extraction system

OZCO BUILDING PRODUCTS

# Product & Packaging Specs

50833 Packing

Item #: Case packing

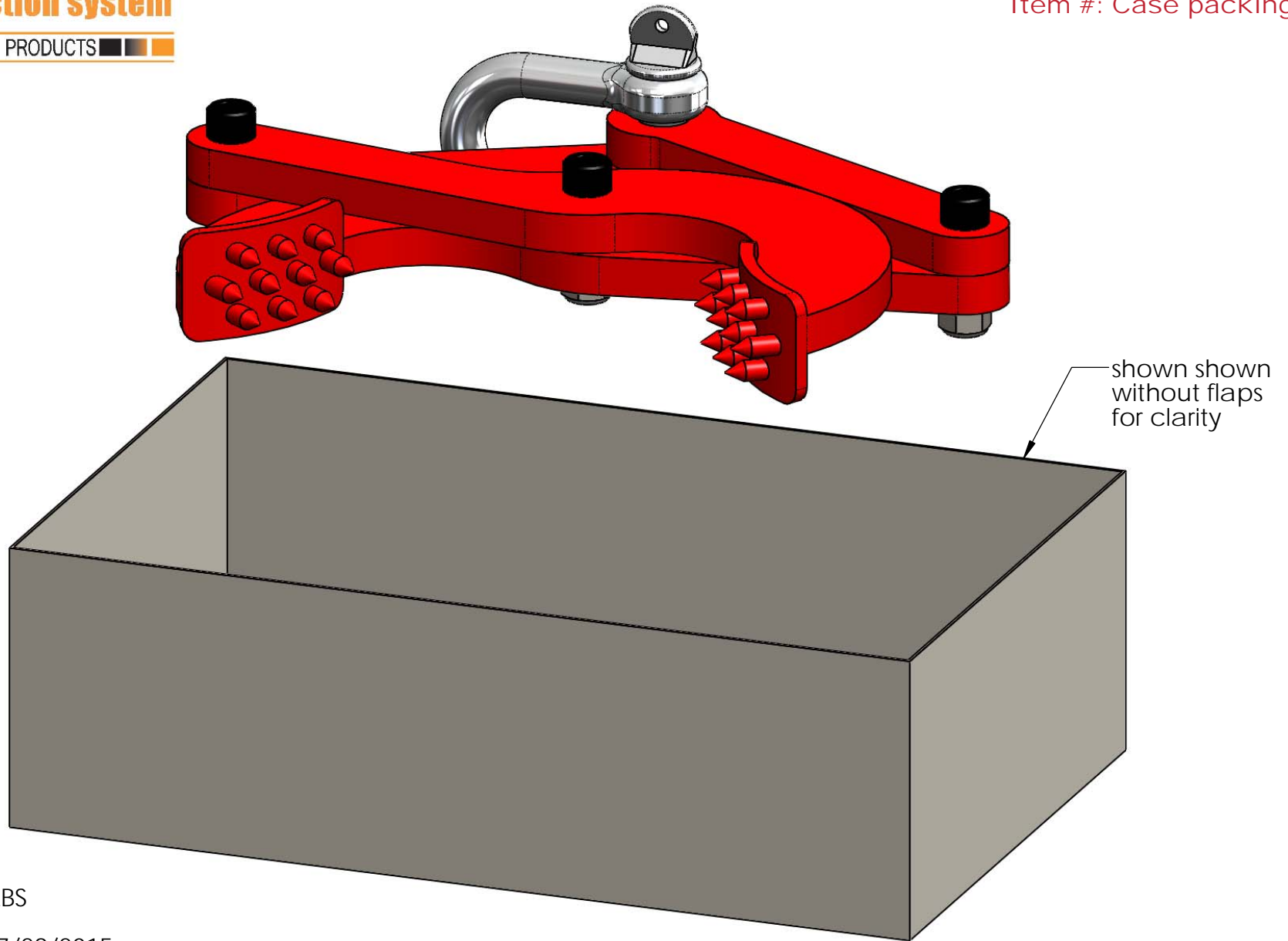

Weight: 10.44 LBS  
Scale: 1:2  
Last updated: 7/29/2015

50833

V1.00 - Installation Instructions effective May 1, 2015 and reflects information that available as of April 10, 2014. This information is updated periodically and should not be relied upon after May 1, 2015. Please visit [www.OZCOBP.com](http://www.OZCOBP.com) to get current information

# Product & Packaging Specs

50833 Packing  
 Item #: Pallet packing

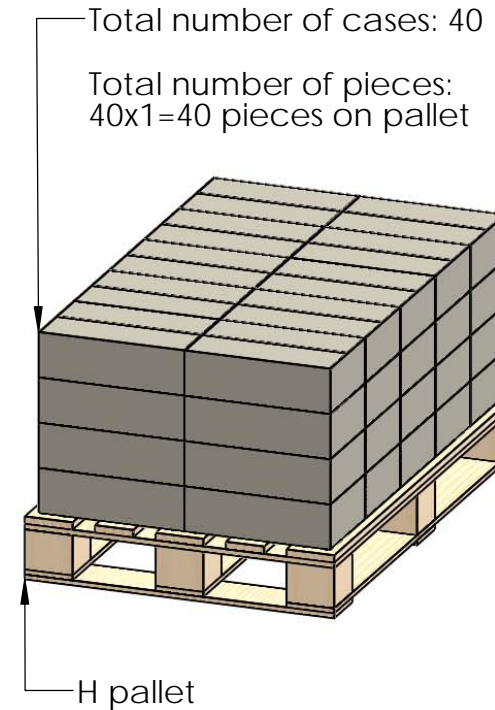
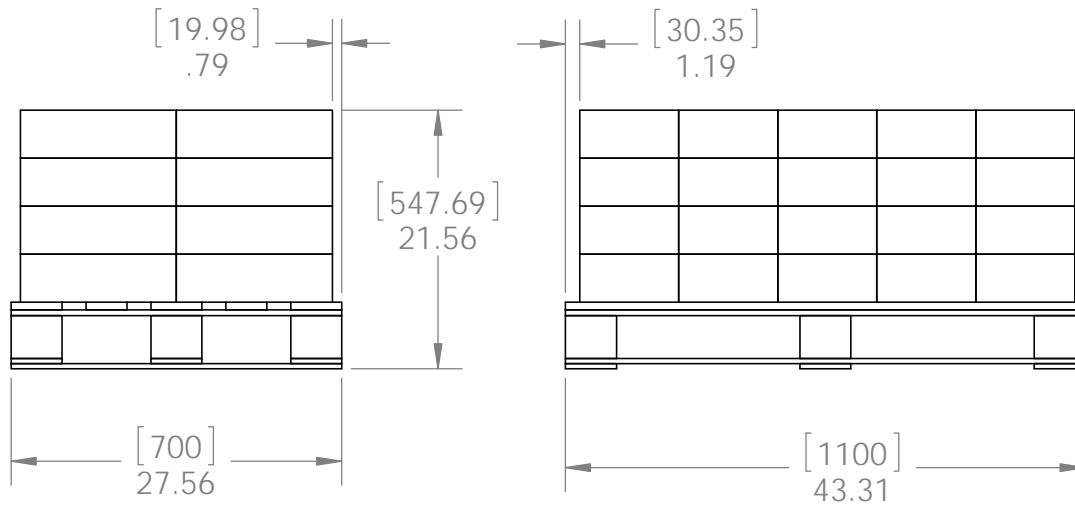

Weight: 450 LBS  
 Scale: 1:16  
 Last updated: 7/29/2015

additional pallet packing instructions  
 plywood on top layer  
 strap to pallet  
 clear wrap around boxes