



OZCO BUILDING PRODUCTS

Product & Packaging Specs

4x4 Post Base

Item #: 56607

ITEM NO.	QTY.	PART NUMBER	DESCRIPTION
1	1	56607-11	Assembly, 4x4 Stand Off
2	4	56607-15	Plate, 4x4 Side Compression
3	8	56621	1 1/2" Hex Cap Nut
4	8	56625	OWT Timber Screw 1-3/4"

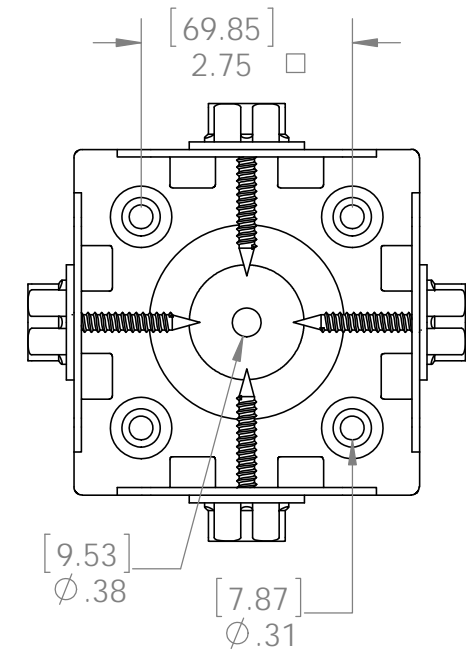
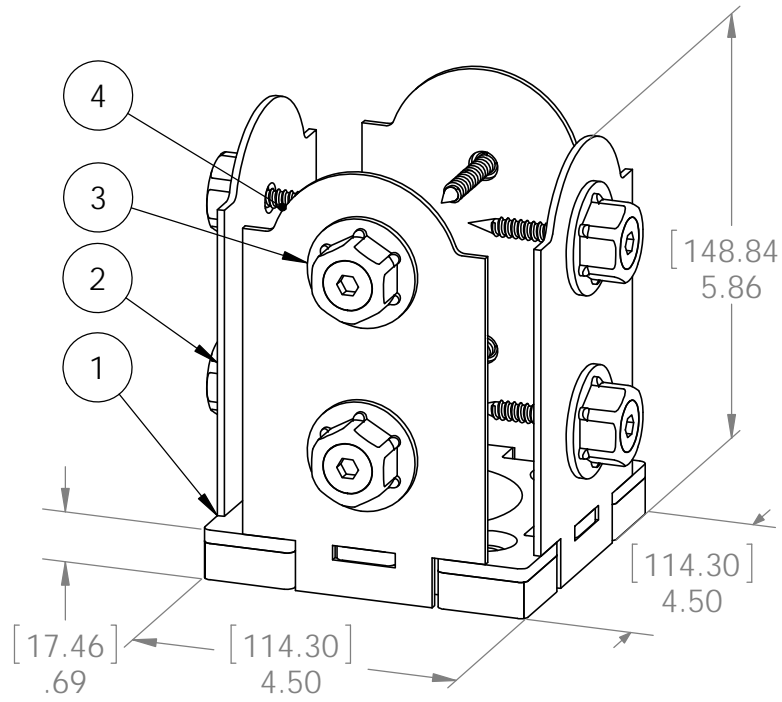
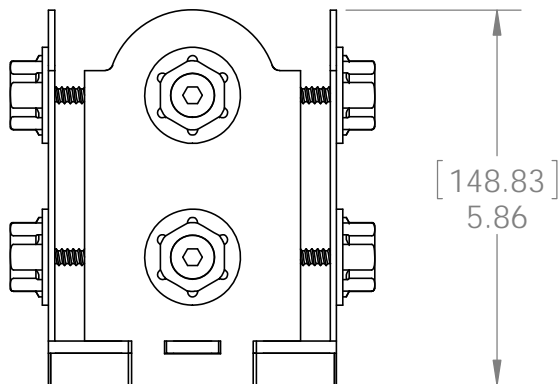
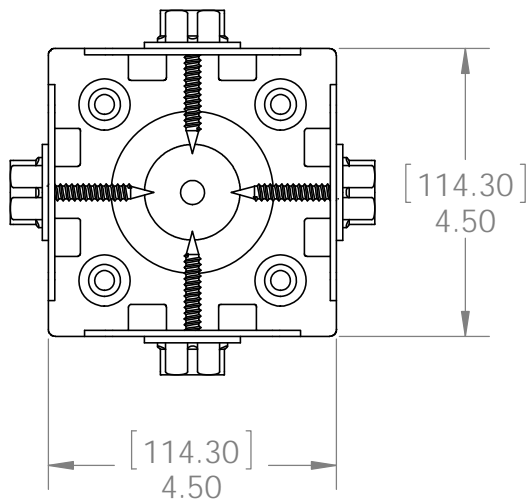

Weight: 3.01 LBS
 Scale: 1:2
 Last updated: 7/13/2015

56607-10

Product & Packaging Specs

56607 Packing

Item #: Box packing

ITEM NO.	QTY.	PART NUMBER	DESCRIPTION
1	1	Post Base Kit Boxes	Box, 4x4 Post Base
2	1	56607-10	4x4 Post Base

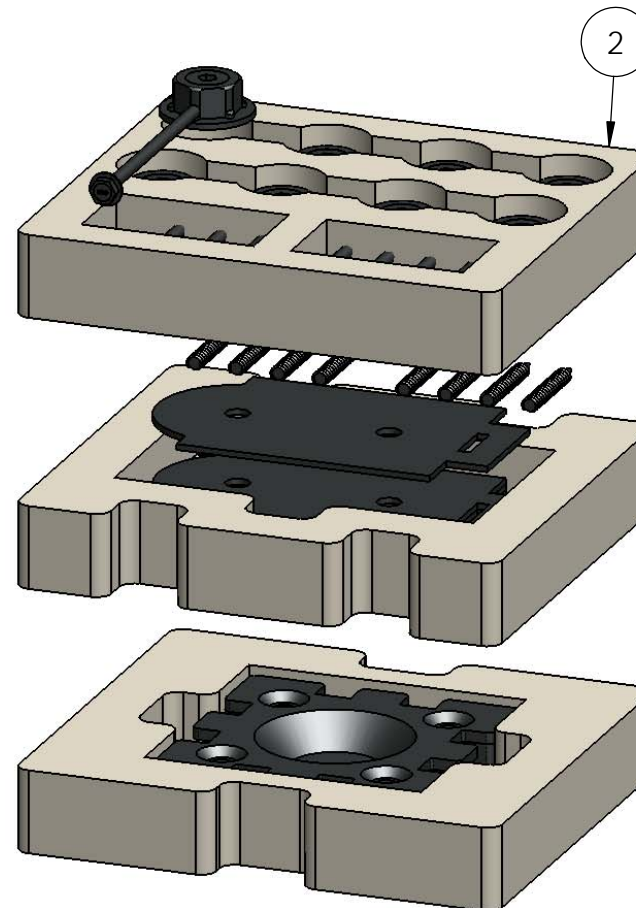

Items not shown:
 installation instructions
 parts wrapped in packing foam sheet

Weight: 4.63 LBS
 Scale: 1:3
 Last updated: 7/13/2015

56607-10

Product & Packaging Specs

Case, 4x4 Post Base Box

Item #: Case, 56607

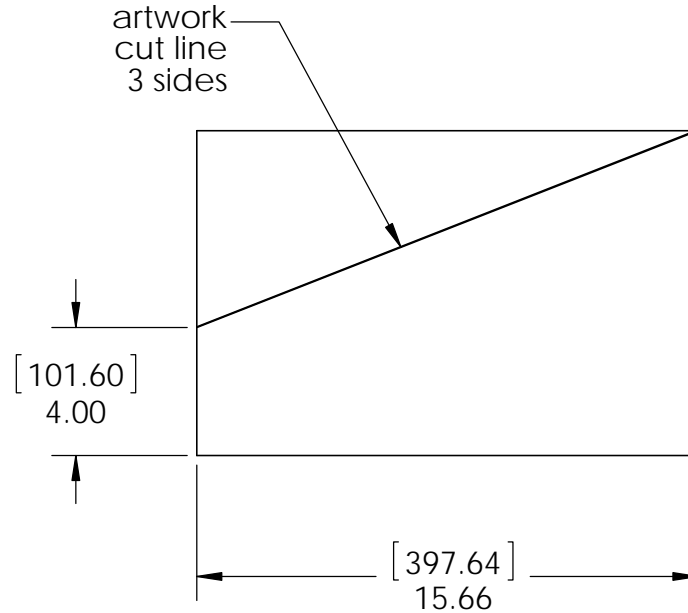
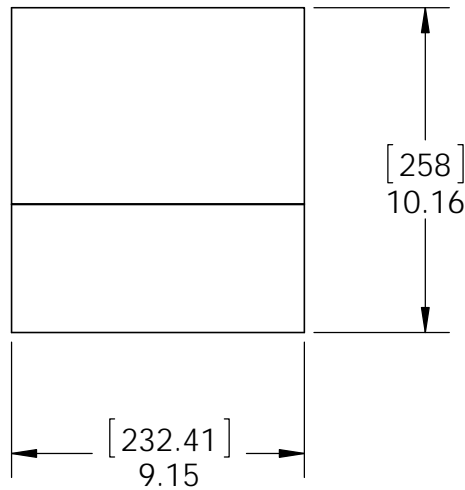
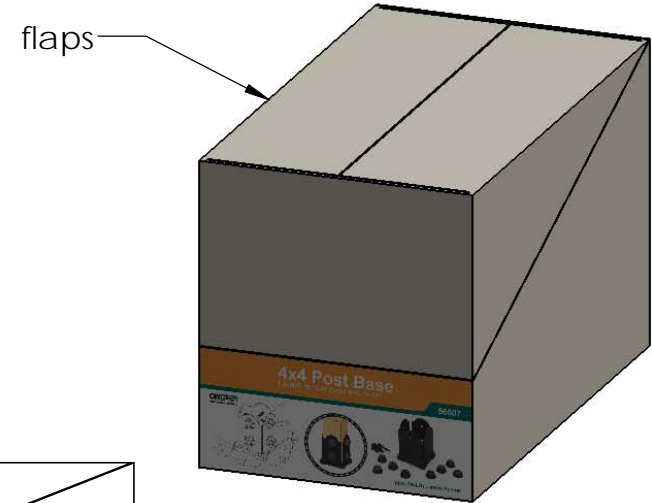

Material: Corrugated Paper
 Finish: See Artwork
 Weight: 0.71 LBS
 Scale: 1:6
 Last updated: 7/13/2015

56607-10

Product & Packaging Specs

56607 Packing
 Item #: Case packing

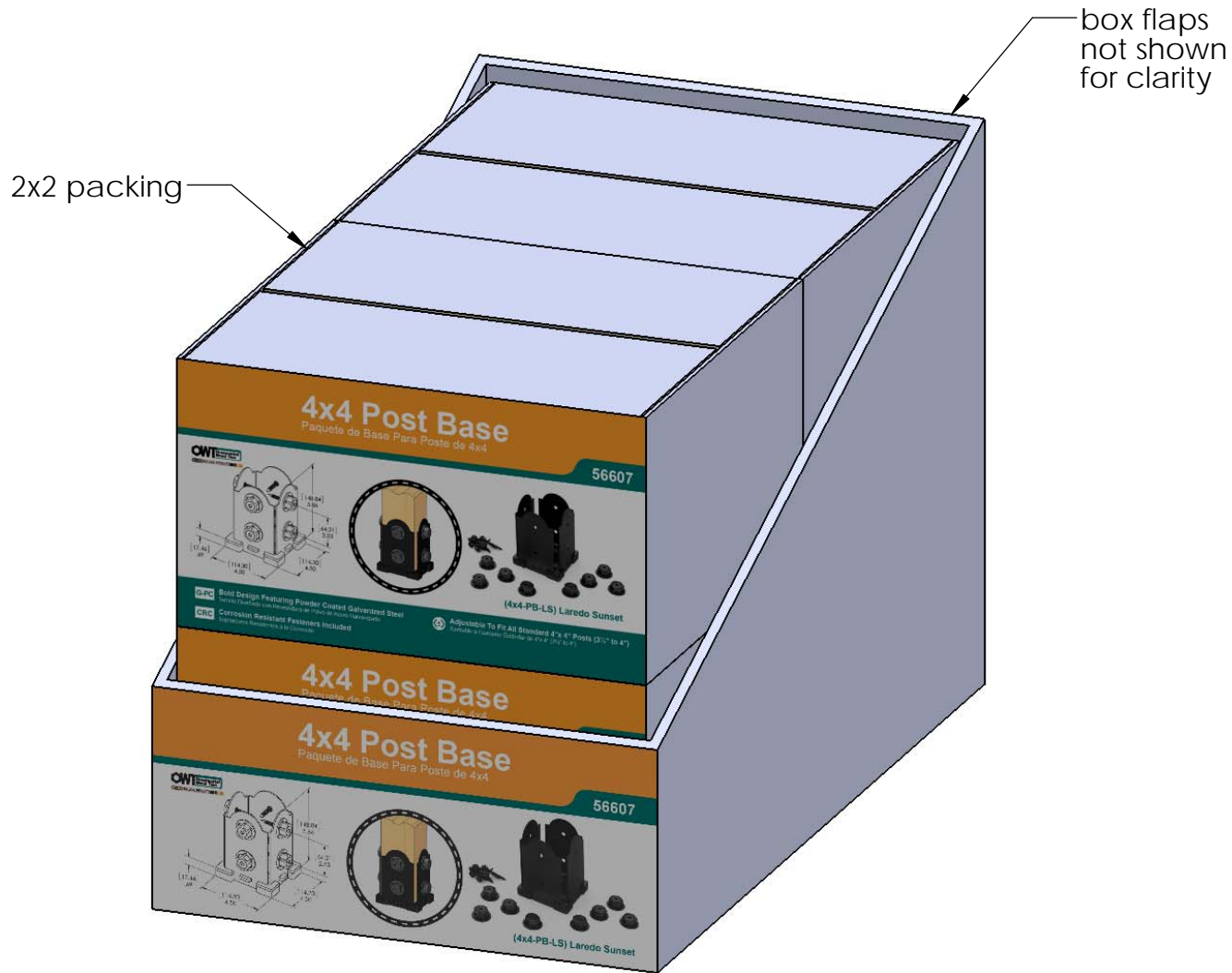

Weight: 18.14 LBS
 Scale: 1:3
 Last updated: 7/13/2015

56607-10

Item #: **56607** | **4x4-PB-LS**
4X4 Post Base Laredo Sunset

PALLET | **120 pcs**

SKU#: **56807** 
7 224 1100009
Made in China

Weight: **569 lbs**

LOT# Priority# 

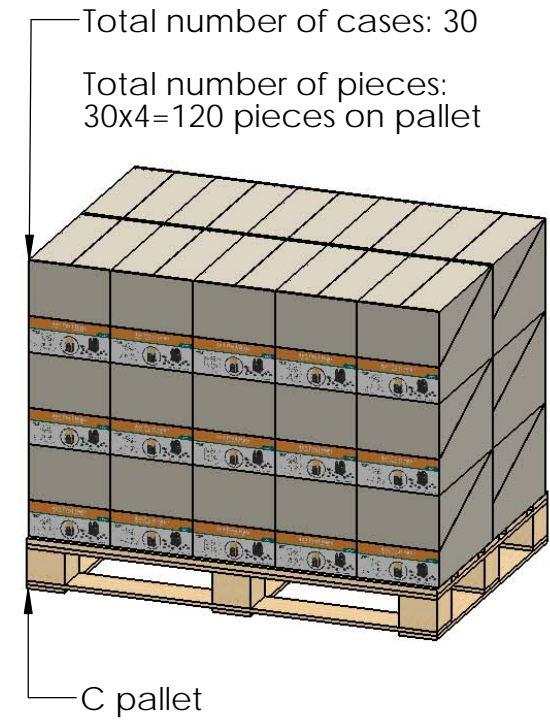
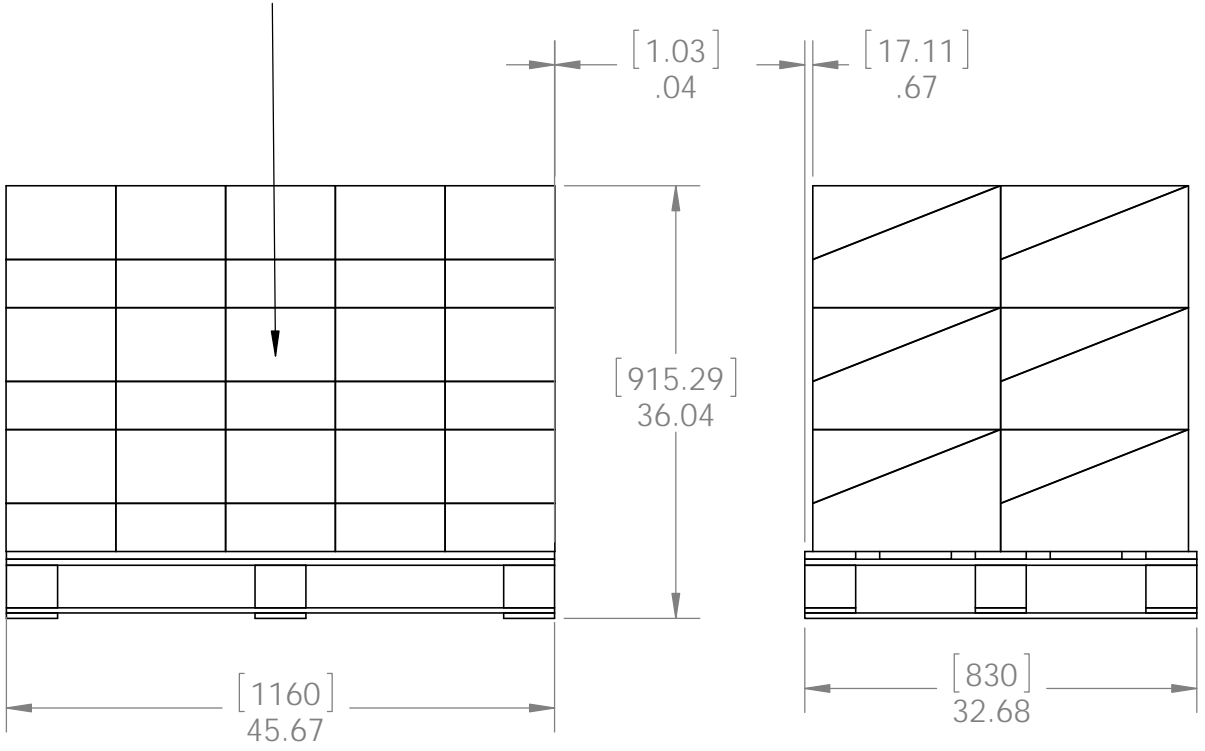

additional pallet packing instructions

- plywood on top layer
- strap to pallet
- clear wrap around boxes

Weight: 569 LBS
 Scale: 1:16
 Last updated: 7/13/2015