

Product & Packaging Specs

2" Standard Rafter Clip

Item #: 56617

ITEM NO.	QTY.	PART NUMBER	DESCRIPTION
1	1	56617-11	Clip, 2" Rafter
2	2	80014	Screw, FHP #12 X 1.25", Black

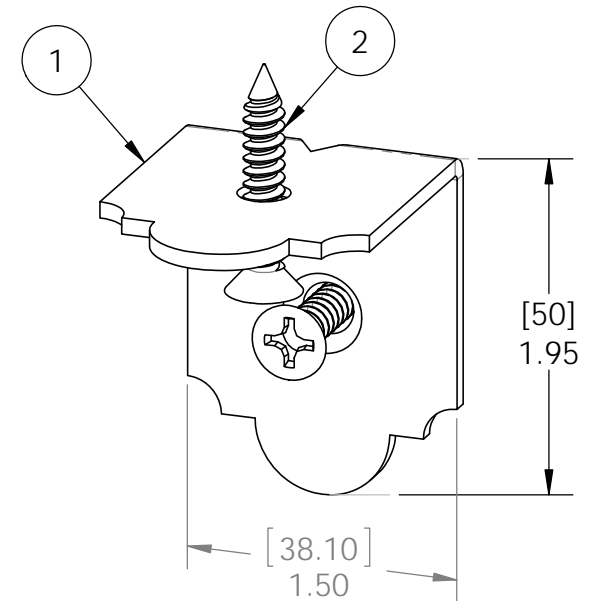
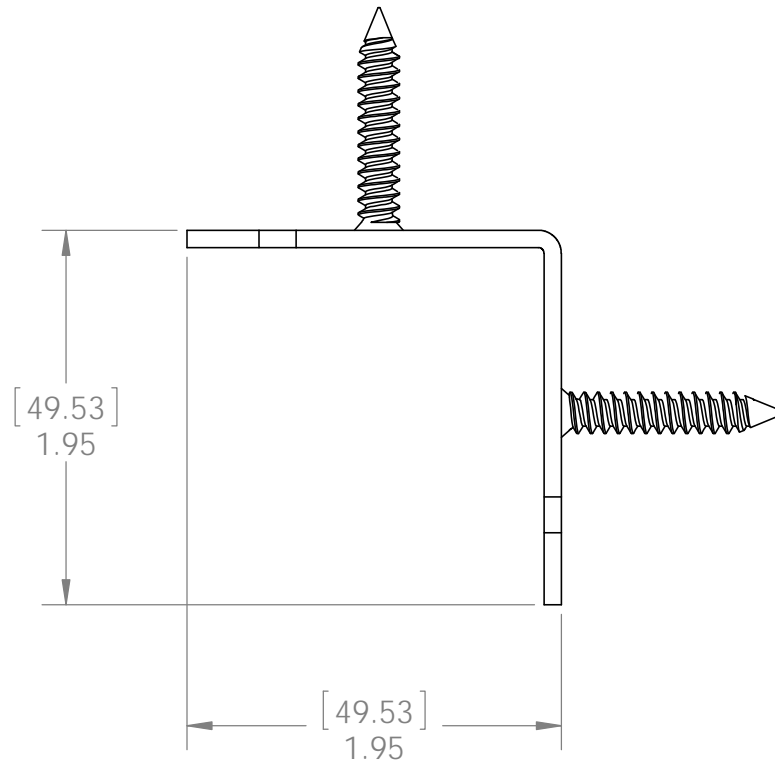
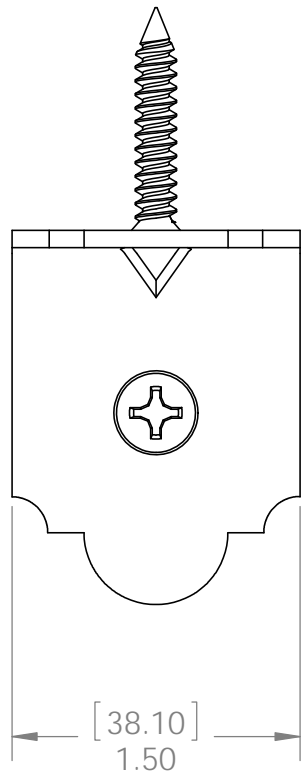

Weight: 2.86 LBS
 Scale: 1:1
 Last updated: 7/13/2015

56617-10

Product & Packaging Specs

2" Standard Rafter Clip

Item #: 56617

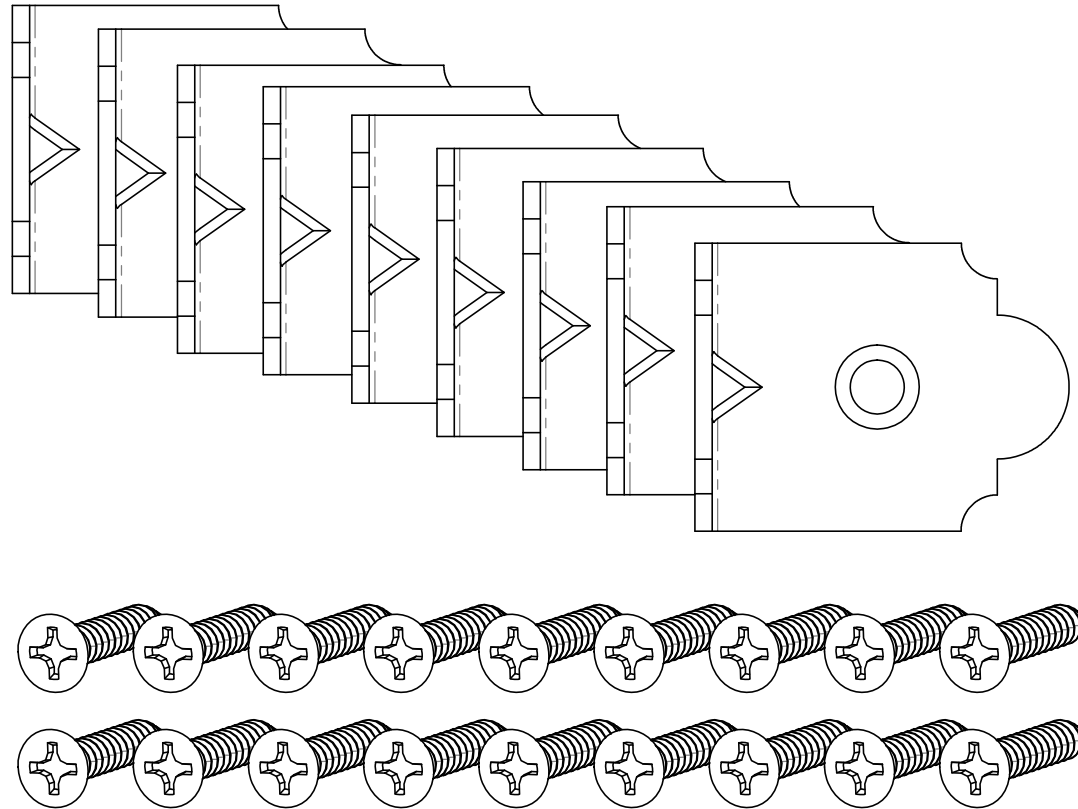
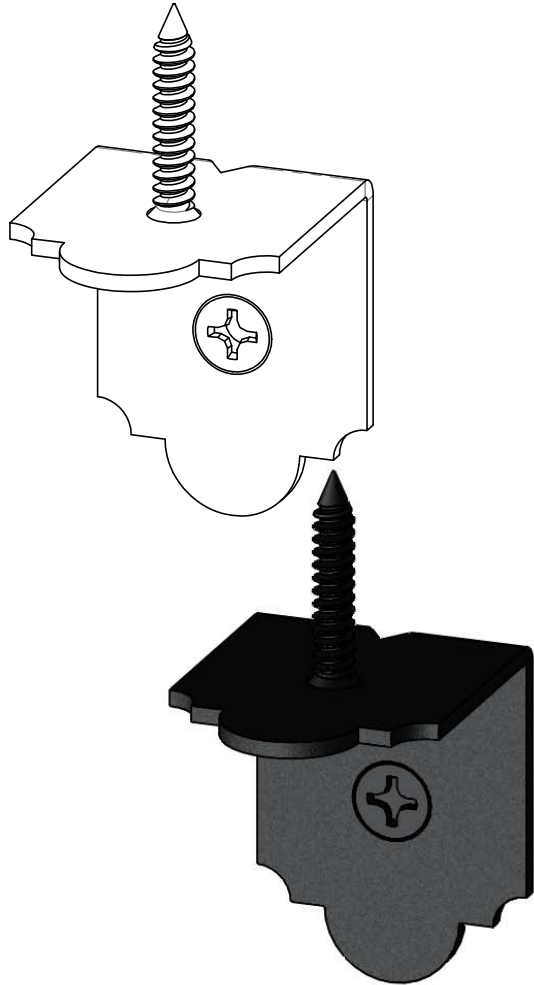

Weight: 2.86 LBS
Scale: 1:1
Last updated: 7/13/2015

56617-10

Product & Packaging Specs

2" Standard Rafter Clip

Item #: Typical Installation & Basic Assembly

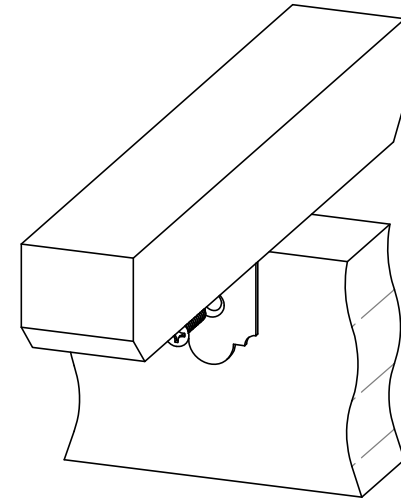
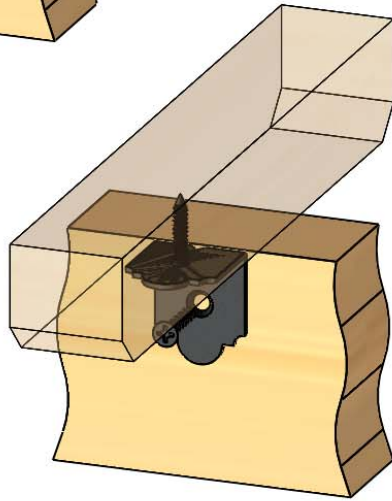
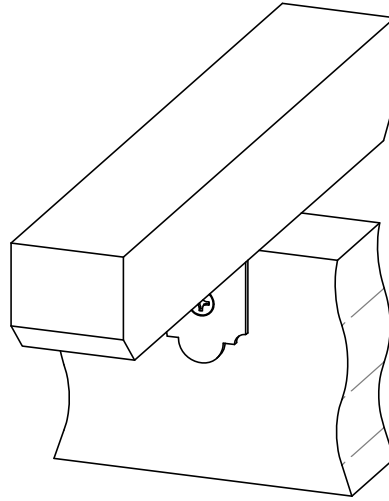
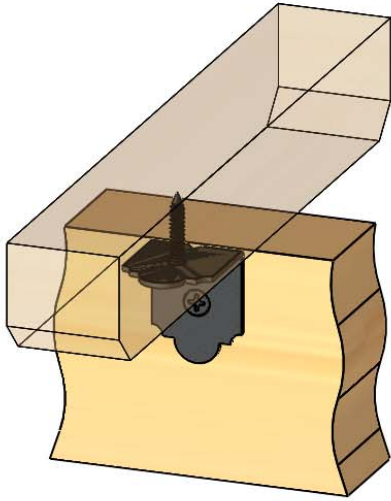

Scale: 1:3
Last updated: 7/13/2015

Product & Packaging Specs

56617 Packing

Item #: Box packing

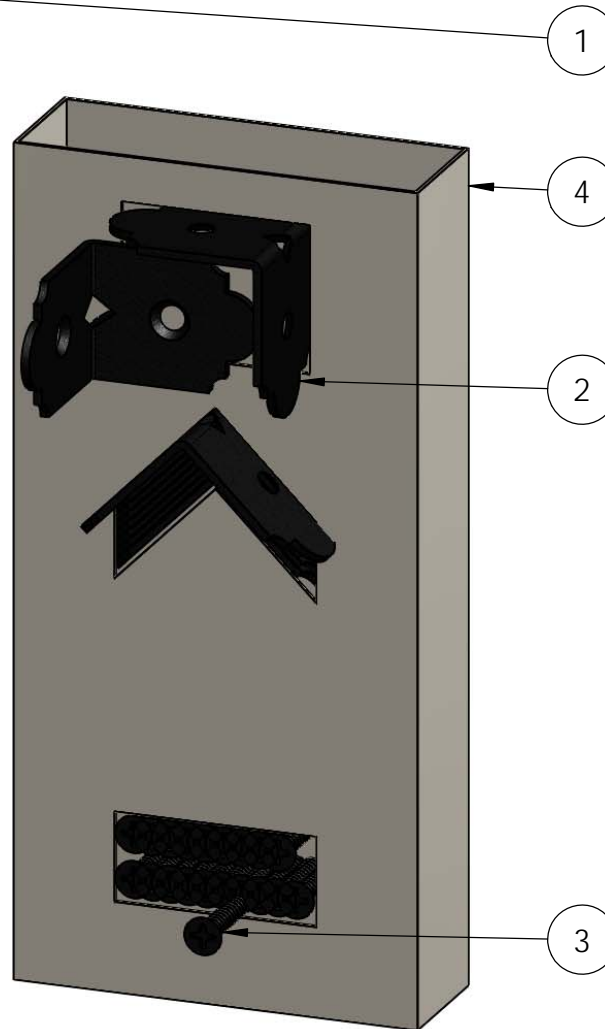

ITEM NO.	QTY.	PART NUMBER	DESCRIPTION
1	1	Box, 56617	Box, 6-8" Joist Hanger
2	10	56617-11	Clip, 2" Rafter
3	20	80014	Screw, FHP #12 X 1.25", Black
4	1	56617 Box Insert	Insert, 56617

screws shall be placed in plastic bag and packed as shown

Weight: 638.89 LBS
 Scale: 1:2
 Last updated: 7/13/2015

56617-10

Product & Packaging Specs

Case, 56638

Item #: Case

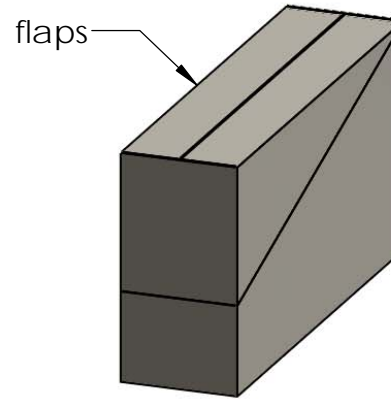

artwork
scoreline
3 sides

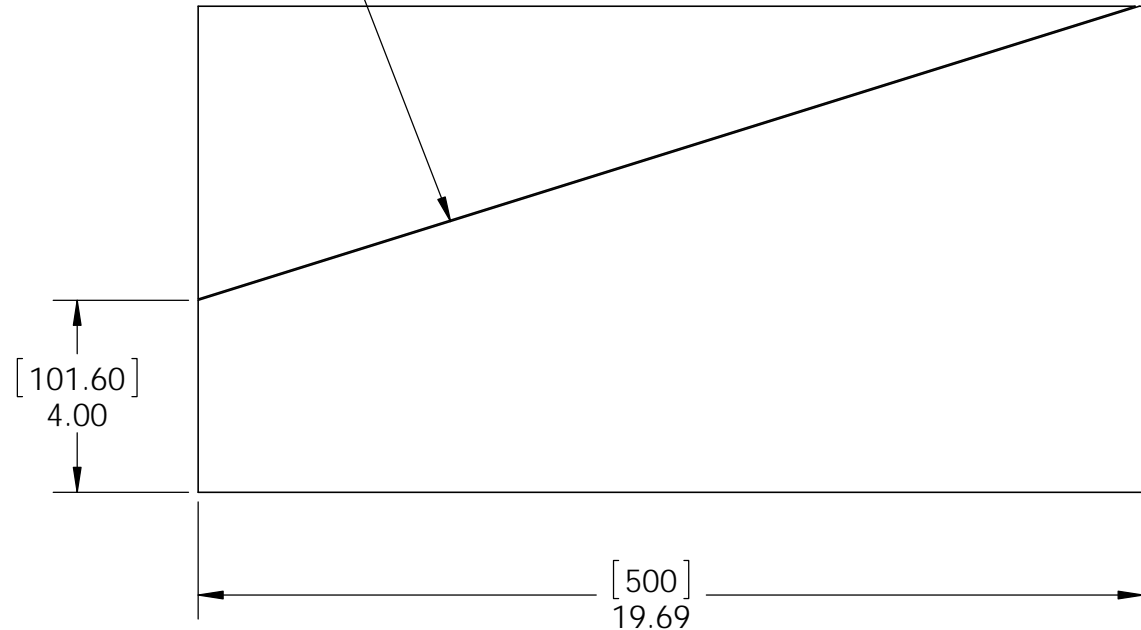
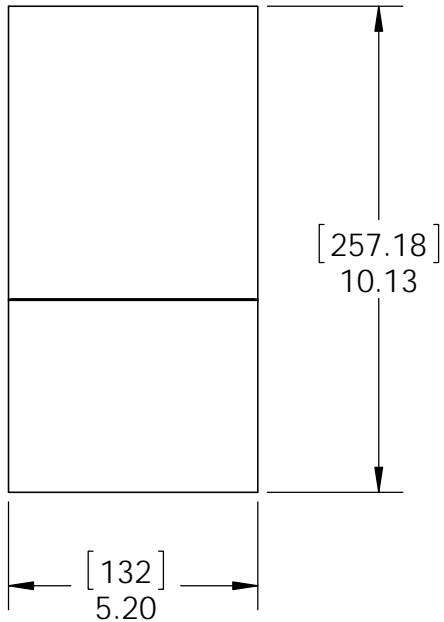

Material: Corrugated Paper
 Finish: See Artwork
 Weight: 0.31 LBS
 Scale: 1:6
 Last updated: 7/13/2015

56617-10

Product & Packaging Specs

56617 Packing

Item #: Case packing

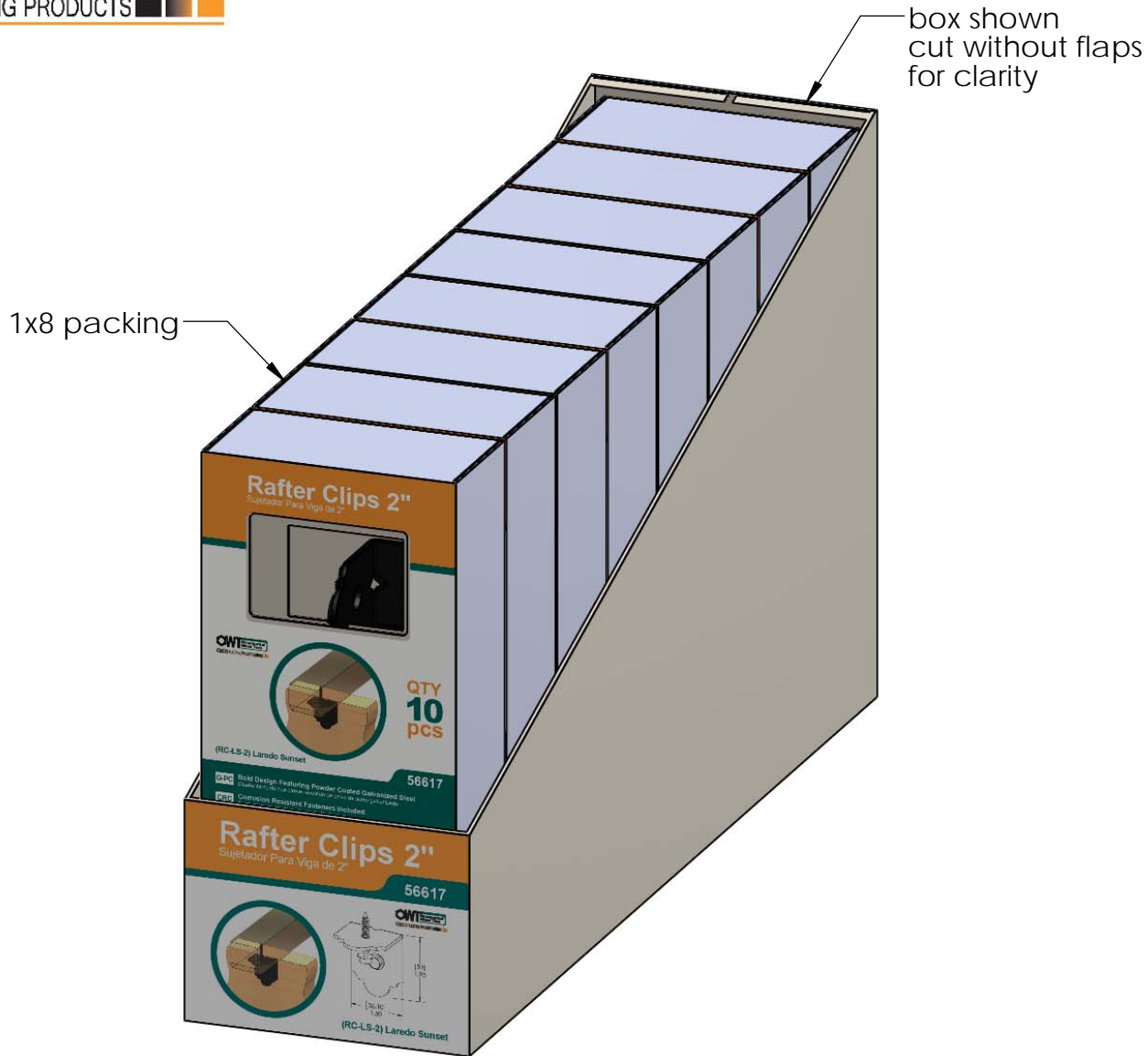

Weight: 16.64 LBS
 Scale: 1:3
 Last updated: 7/13/2015

56617-10

Item #: **56617** | **RC-LS-2**
 2" Rafter Clips LS
PALLET 160 pcs
 SKU#: **56817**
 Weight: 384 lbs
 LOT# _____ Priority# _____

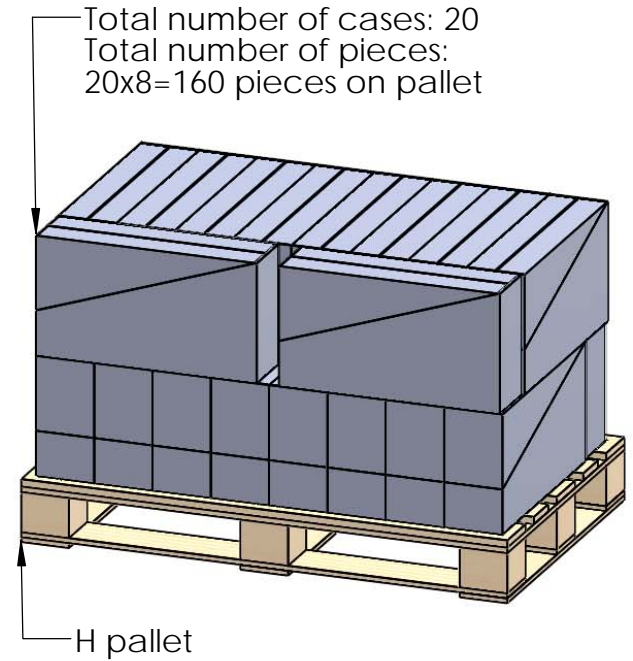
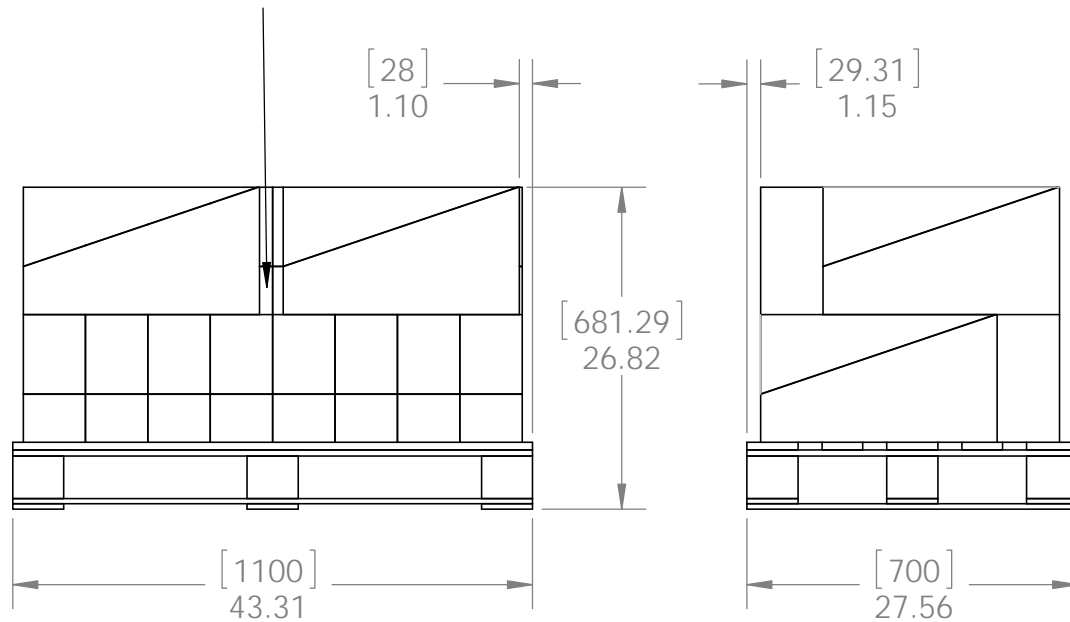

additional pallet packing instructions

- plywood on top layer
- strap to pallet
- clear wrap around boxes

Weight: 384 LBS
 Scale: 1:16
 Last updated: 7/13/2015