

# Product & Packaging Specs

2-3/8" OD Star

Item #: 56623

ITEM NO.	QTY.	PART NUMBER	DESCRIPTION
1	1	56623-11	Star 2-3/8" OD
2	1	80005	Screw, #6 x 1-3/4 FHP, Black

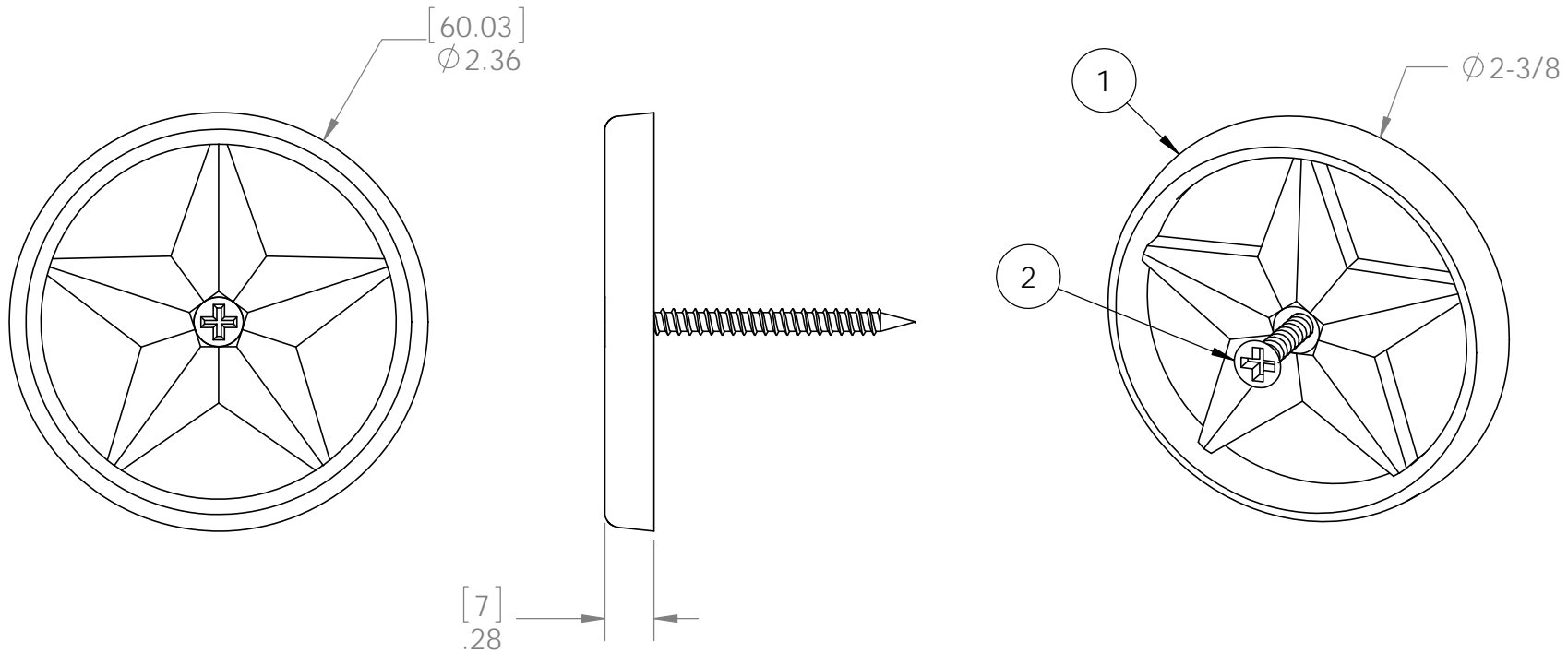

Weight: 1.28 LBS  
 Scale: 1:1  
 Last updated: 7/13/2015

56623-10

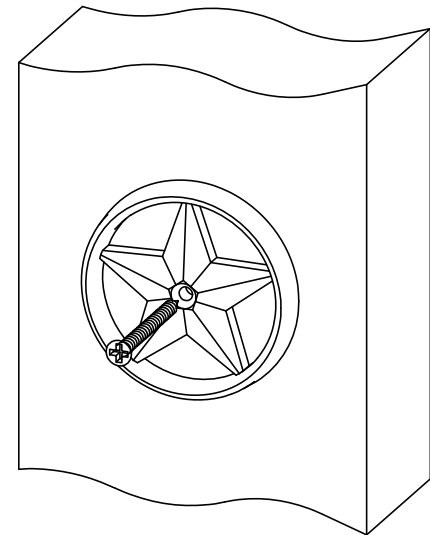
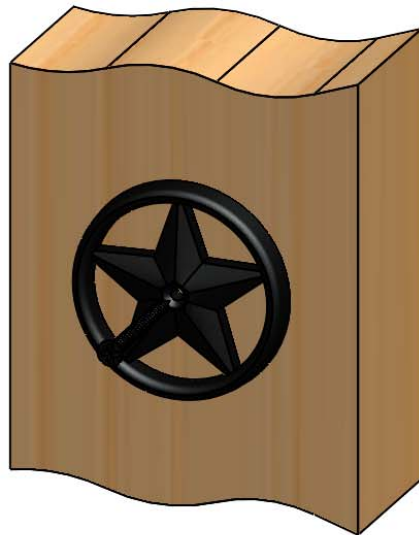
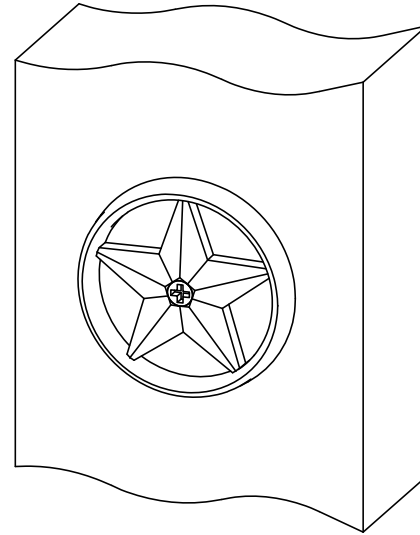
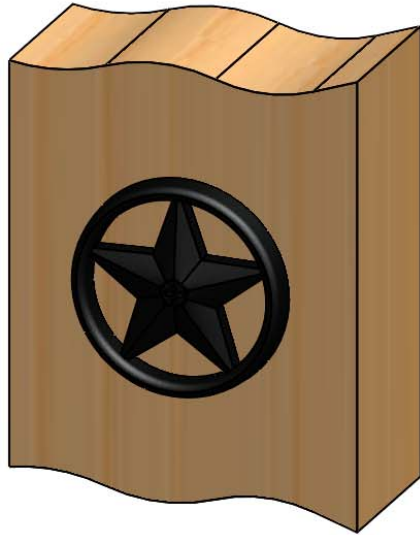

Weight: 1.28 LBS  
Scale: 1:2  
Last updated: 7/13/2015

56623-10

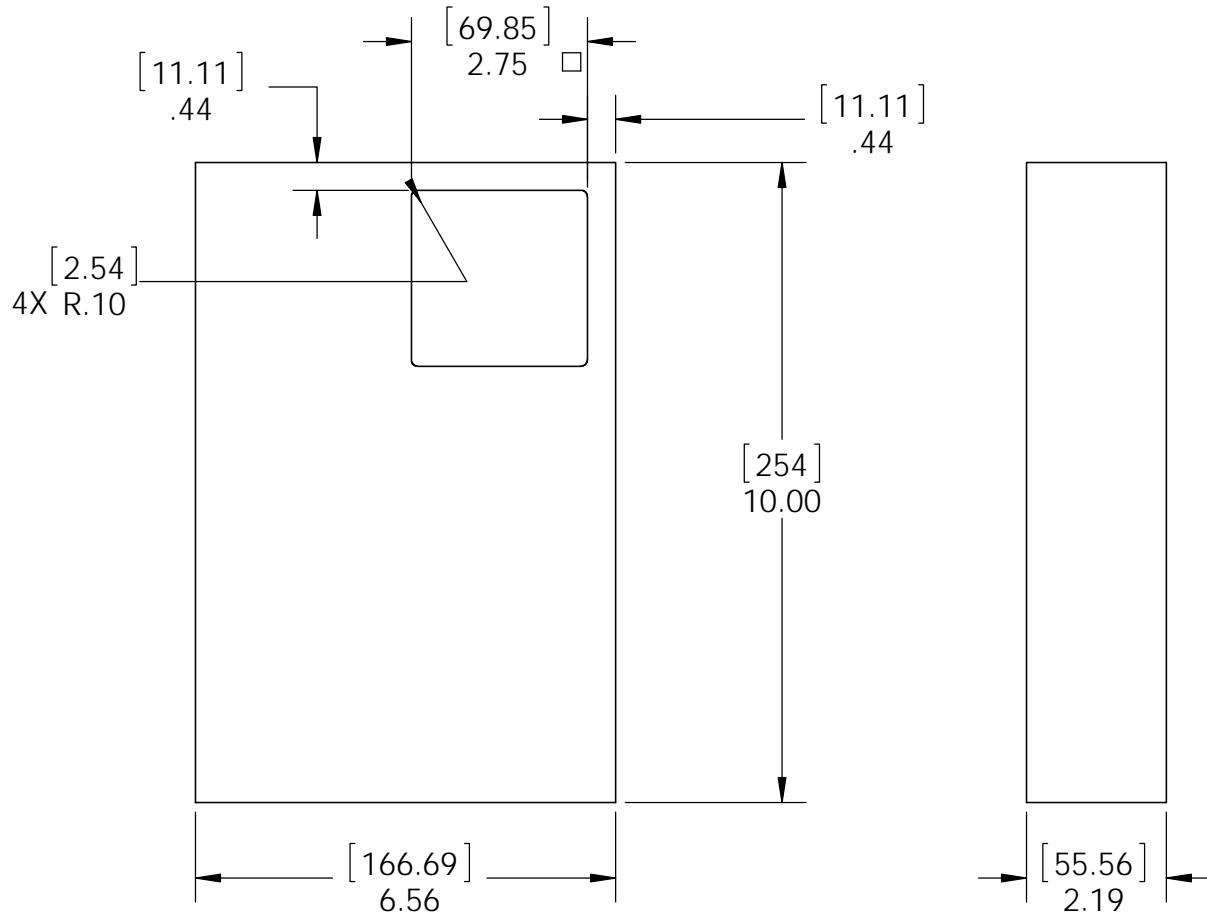

Material: Corrugated Paper  
Finish: See artwork  
Weight: 0.09 LBS  
Scale: 1:3  
Last updated: 7/13/2015

56623-10



OZCO BUILDING PRODUCTS

# Product & Packaging Specs

## 56623 Packing

Item #: Box packing

ITEM NO.	QTY.	PART NUMBER	DESCRIPTION
1	1	56623 Star Box	Box, 2-3/8" Star
2	1	56623 Star Box Insert	Insert, 2-3/8" Star Box
3	5	56623-11	Star 2-3/8" OD

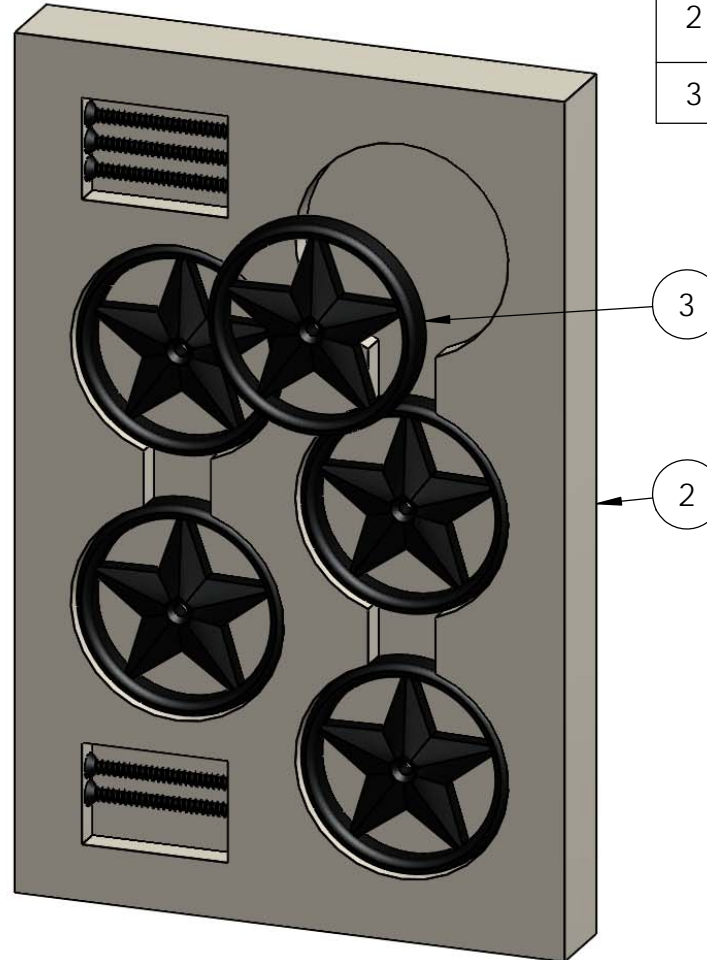

Weight: 0.68 LBS  
 Scale: 1:2  
 Last updated: 7/13/2015

56623-10

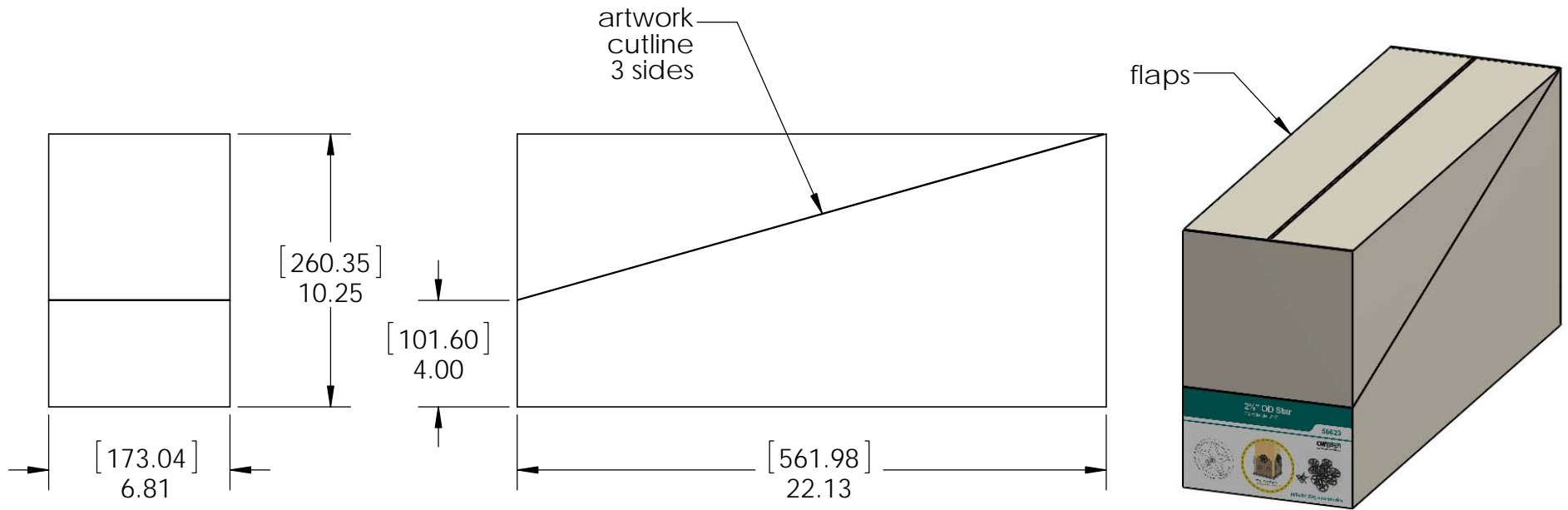

Material: Corrugated Paper  
 Finish: See artwork  
 Weight: 0.21 LBS  
 Scale: 1:6  
 Last updated: 7/13/2015

56623-10

# Product & Packaging Specs

56623 Packing

Item #: Case packing

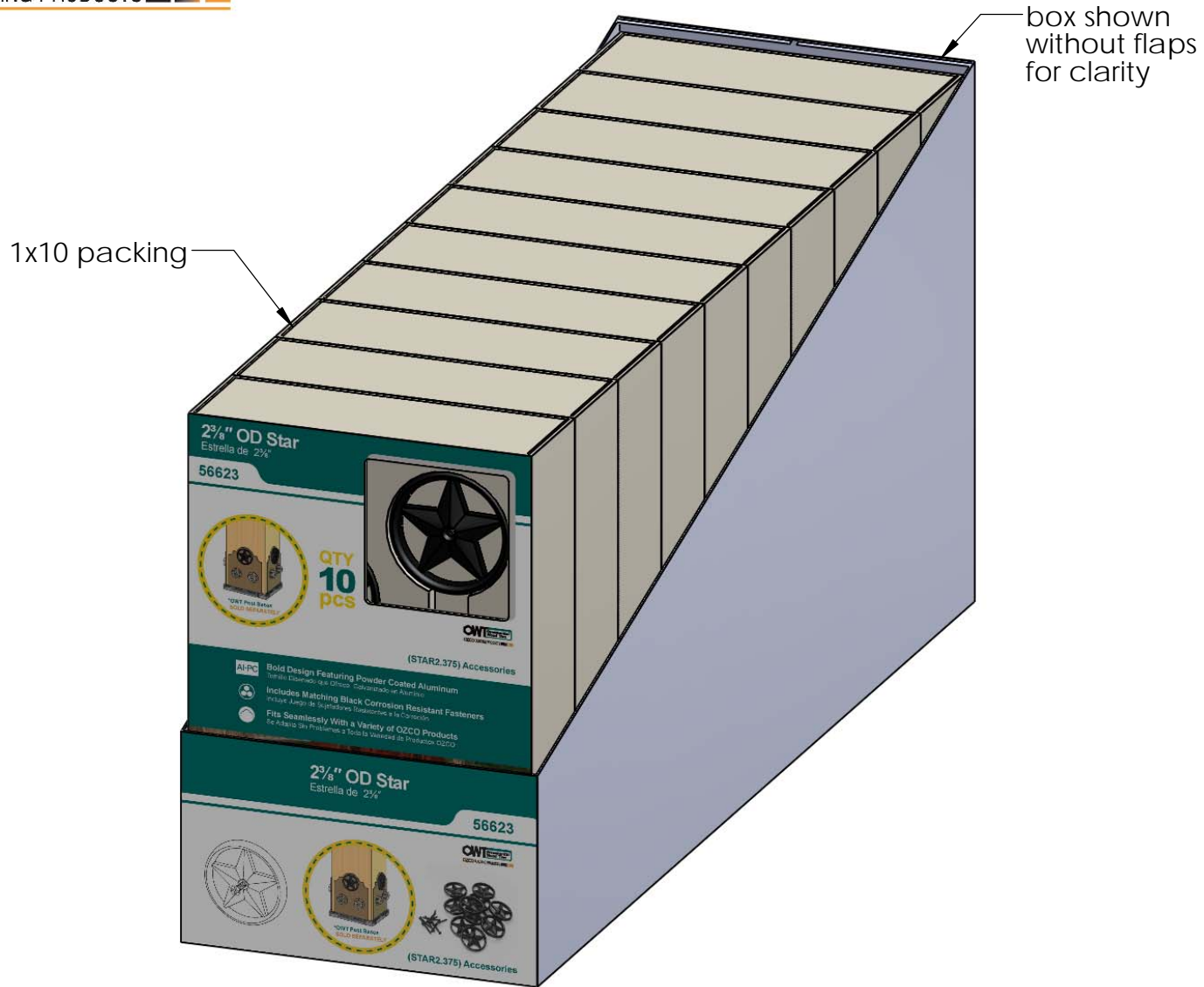

Weight: 7.5 LBS  
 Scale: 1:3  
 Last updated: 7/13/2015

56623-10

# Product & Packaging Specs

## 56623 Packing

Item #: Pallet packing

Item #: **56623** | **STAR2.375**  
 2 3/8" OD Star  
**PALLET** **240 pcs**  
 SKU#: **56823**  
 Weight: **273 lbs**  
 LOT# Priority# 

Total number of cases: 24  
 Total number of pieces:  
 24x10=240 pieces on pallet

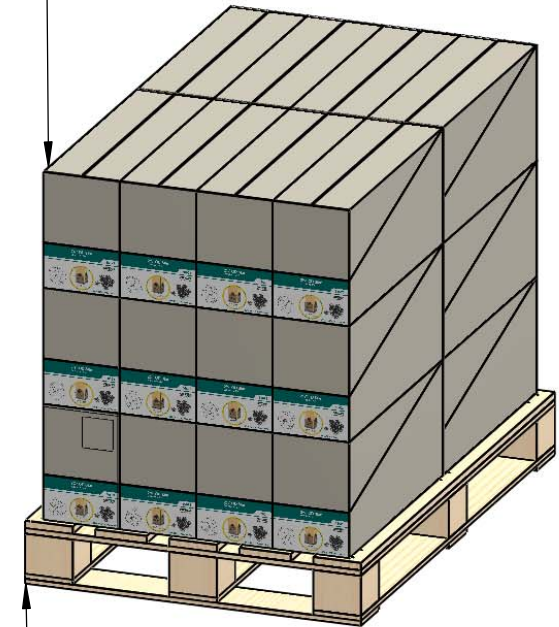

A pallet



additional pallet packing instructions

- plywood on top layer
- strap to pallet
- clear wrap around boxes

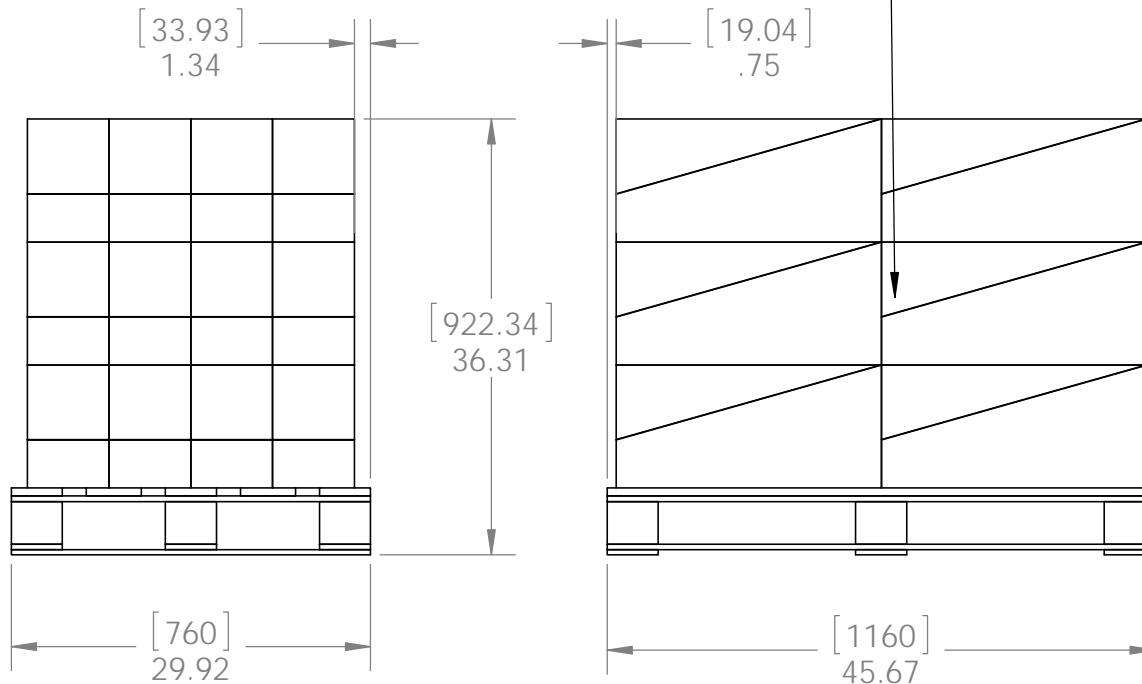

Weight: 273 LBS  
 Scale: 1:16  
 Last updated: 7/13/2015

56623-10