

Product & Packaging Specs

3-3/8" OD Star

Item #: 56624

ITEM NO.	QTY.	PART NUMBER	DESCRIPTION
1	1	56624-11	STAR 3-3/8" OD
2	1	80005	Screw, #6 x 1-3/4 FHP, Black

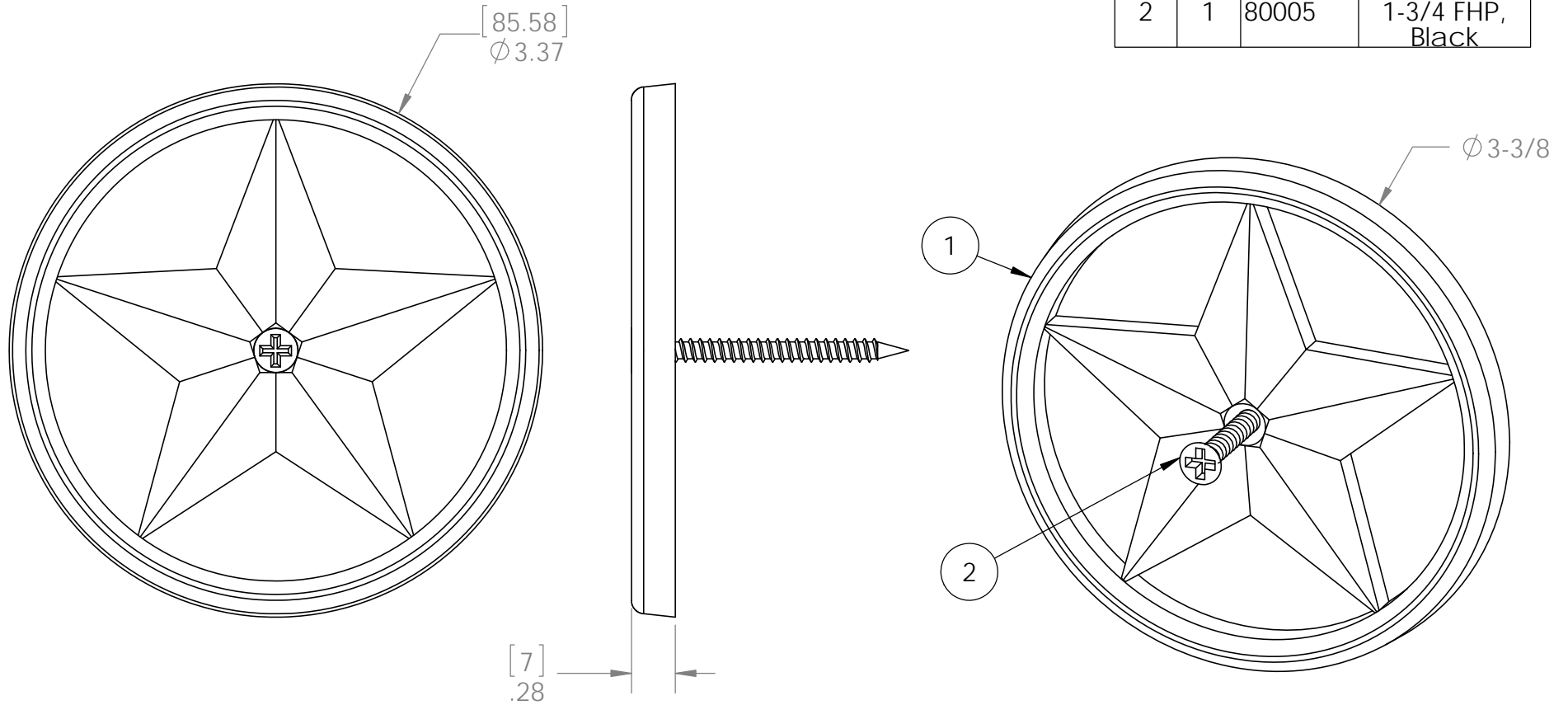

Weight: 1.33 LBS
 Scale: 1:1
 Last updated: 7/13/2015

56624-10

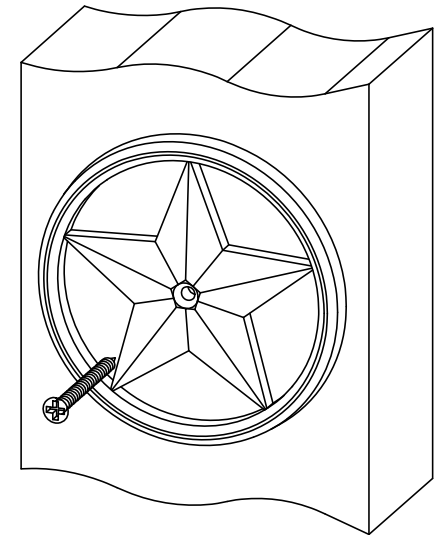
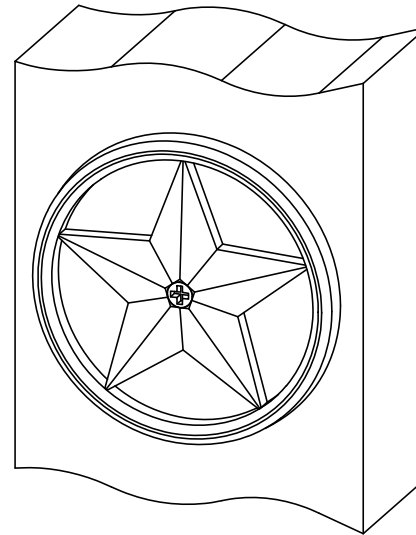
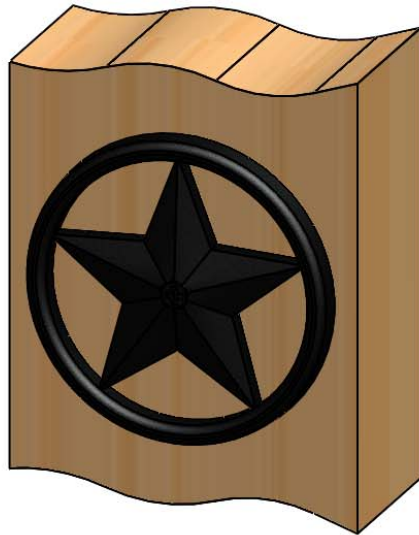

Weight: 1.33 LBS
Scale: 1:2
Last updated: 7/13/2015

56624-10



OZCO BUILDING PRODUCTS

Product & Packaging Specs

Box, 3-3/8" Star

Item #: Box

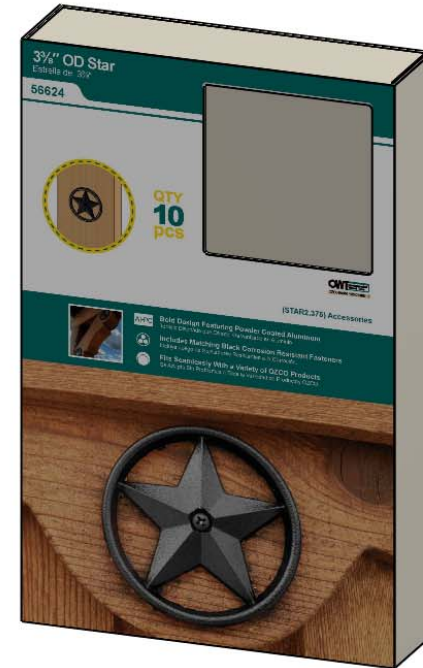
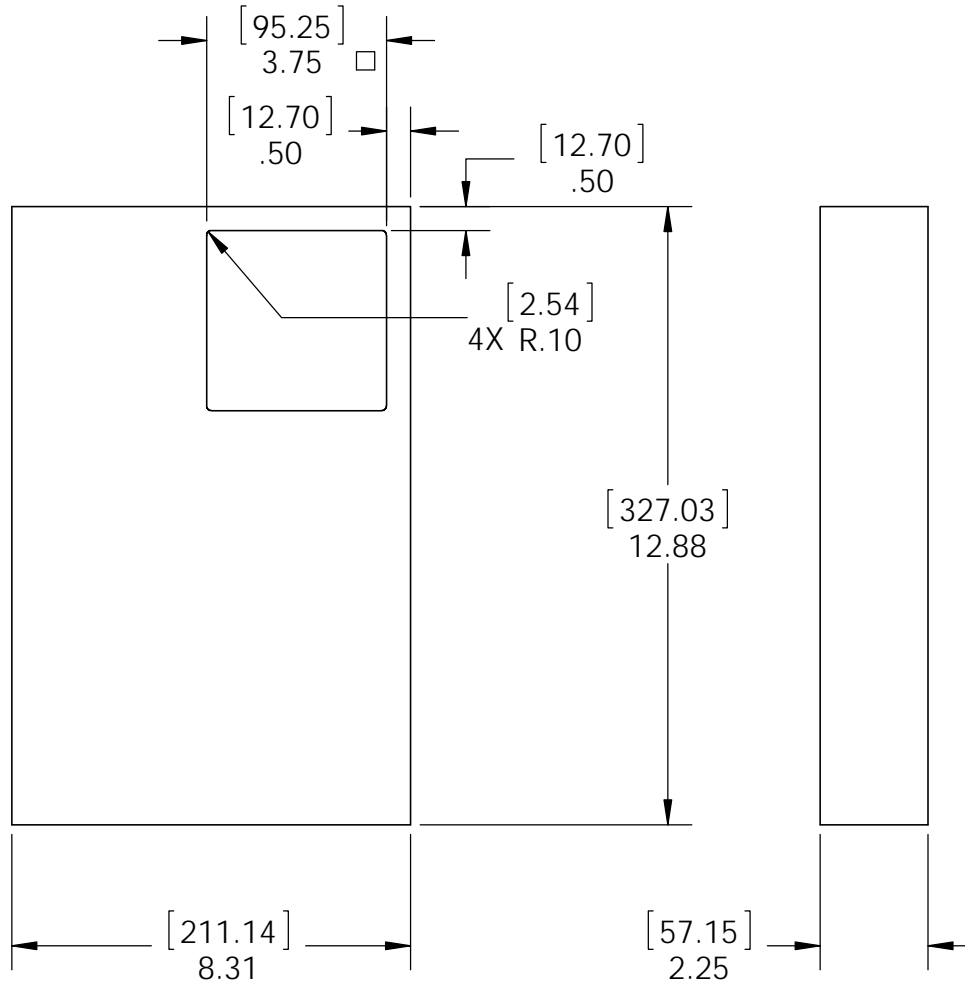

Material: Corrugated Paper
 Finish: See Artwork
 Weight: 0.13 LBS
 Scale: 1:4
 Last updated: 7/13/2015

56624-10

Product & Packaging Specs

56624 Packing

Item #: Box packing

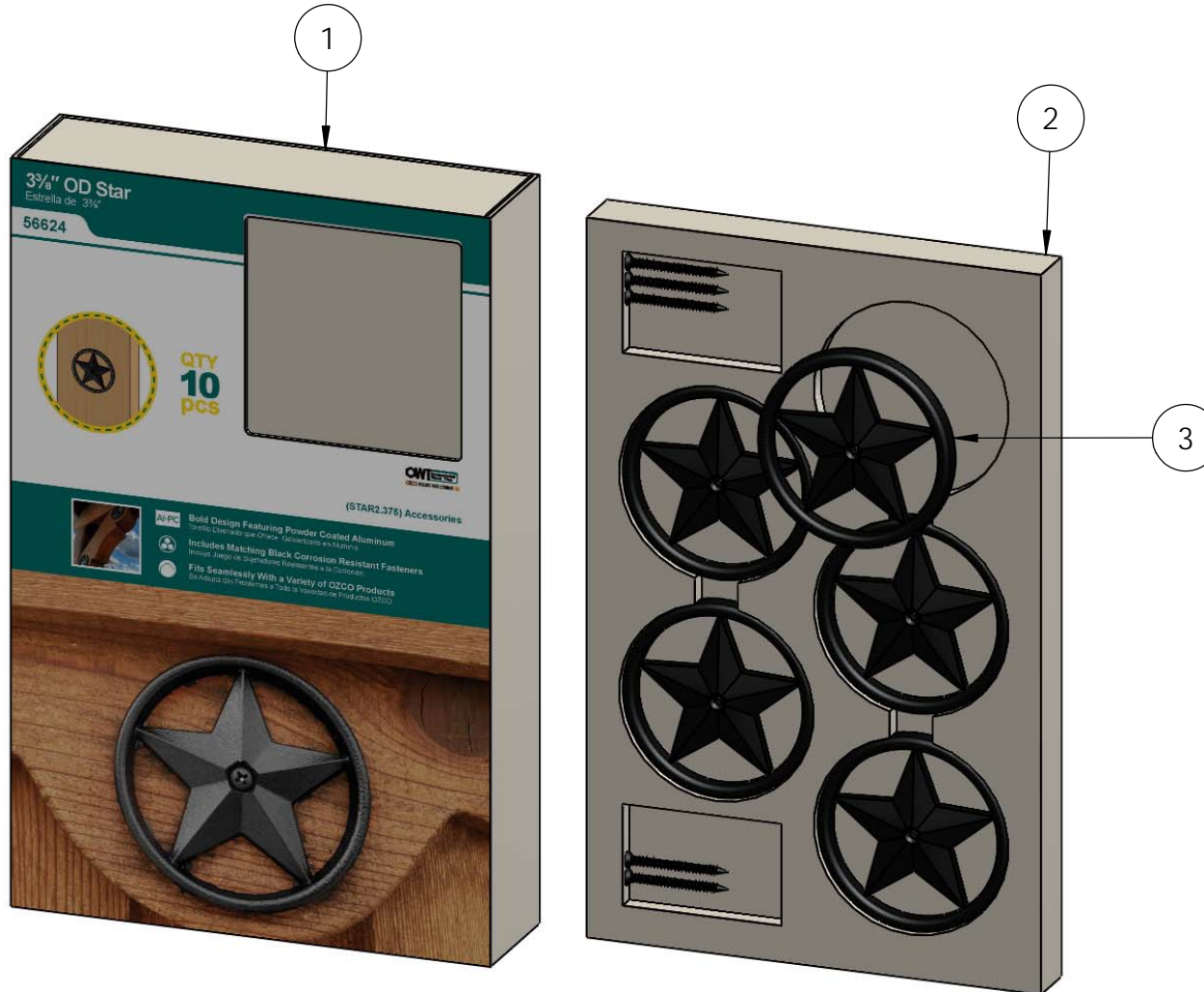

ITEM NO.	QTY.	PART NUMBER	DESCRIPTION
1	1	56624 Star Box	Box, 3-3/8" Star
2	1	56624 Star Box Insert	Insert, 3-3/8" Star
3	5	56624-11	STAR 3-3/8" OD

Weight: 1.14 LBS
 Scale: 1:4
 Last updated: 7/13/2015

56624-10

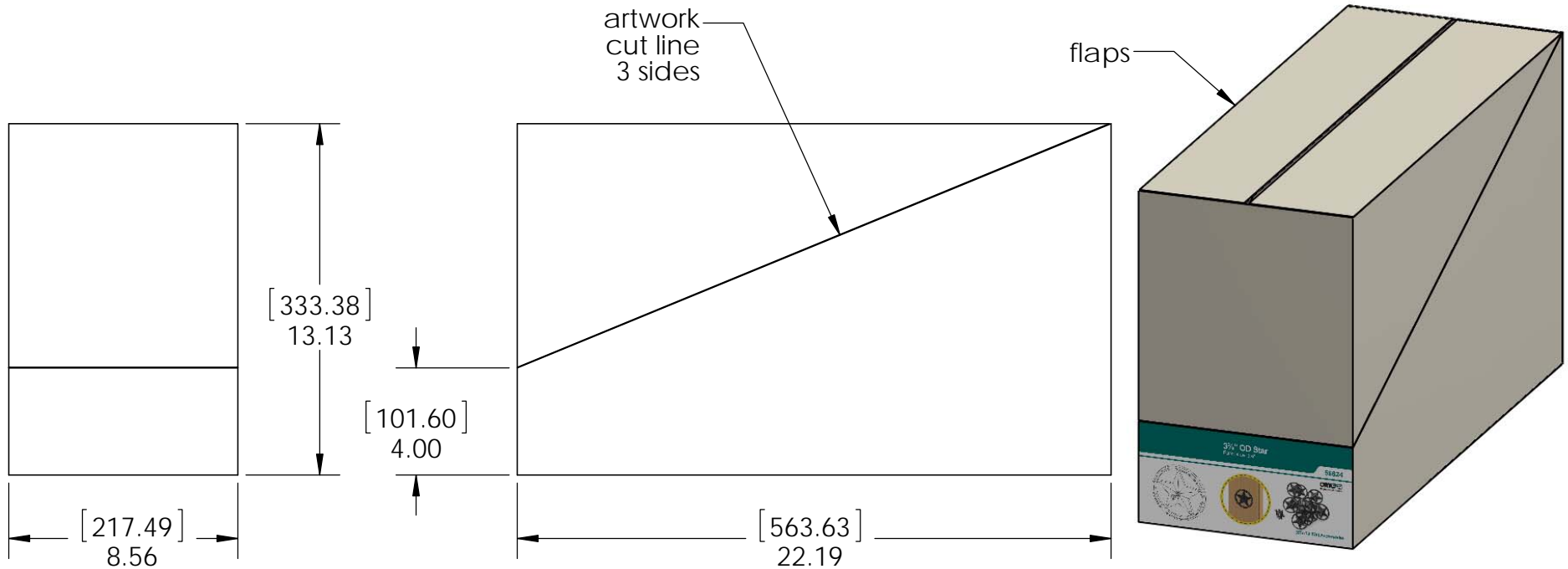

Material: Corrugated Paper
 Finish: See artwork
 Weight: 0.27 LBS
 Scale: 1:6
 Last updated: 7/13/2015

56624-10

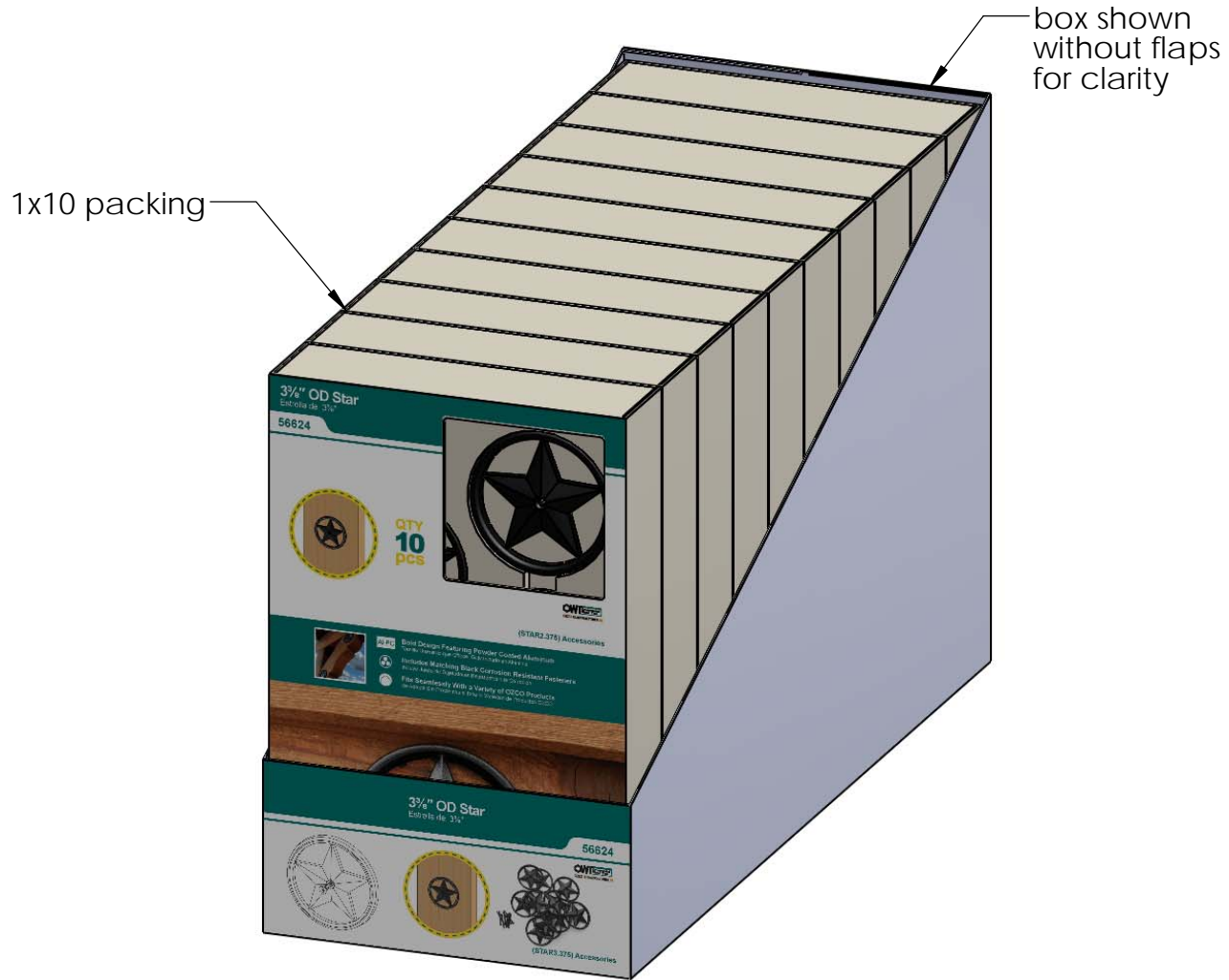

Weight: 12 LBS
Scale: 1:4
Last updated: 7/13/2015

56624-10

Product & Packaging Specs

56624 Packing

Item #: Pallet packing

Item #: **56624** | **STAR3.375**
 3 3/8" OD Star
PALLET | **120 pcs**
 SKU#: **56824**
 Weight: 237 lbs
 LOT# Priority# 

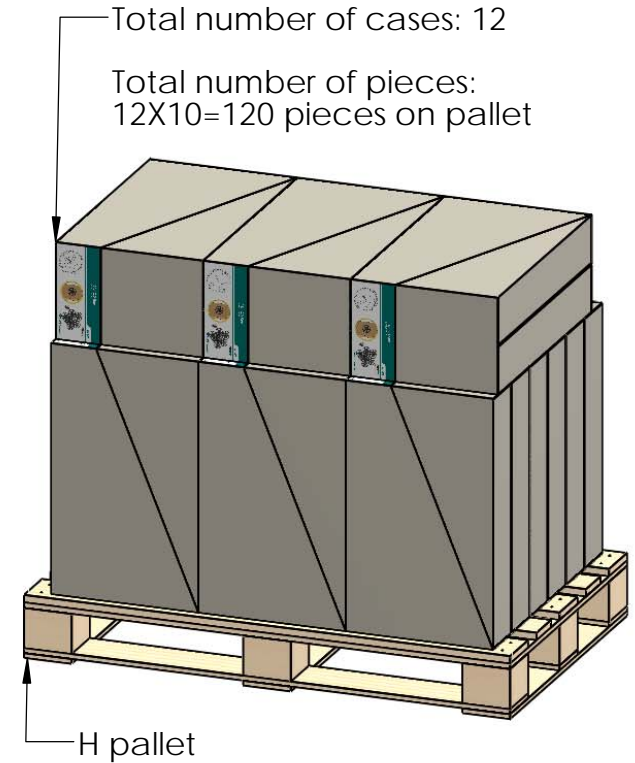
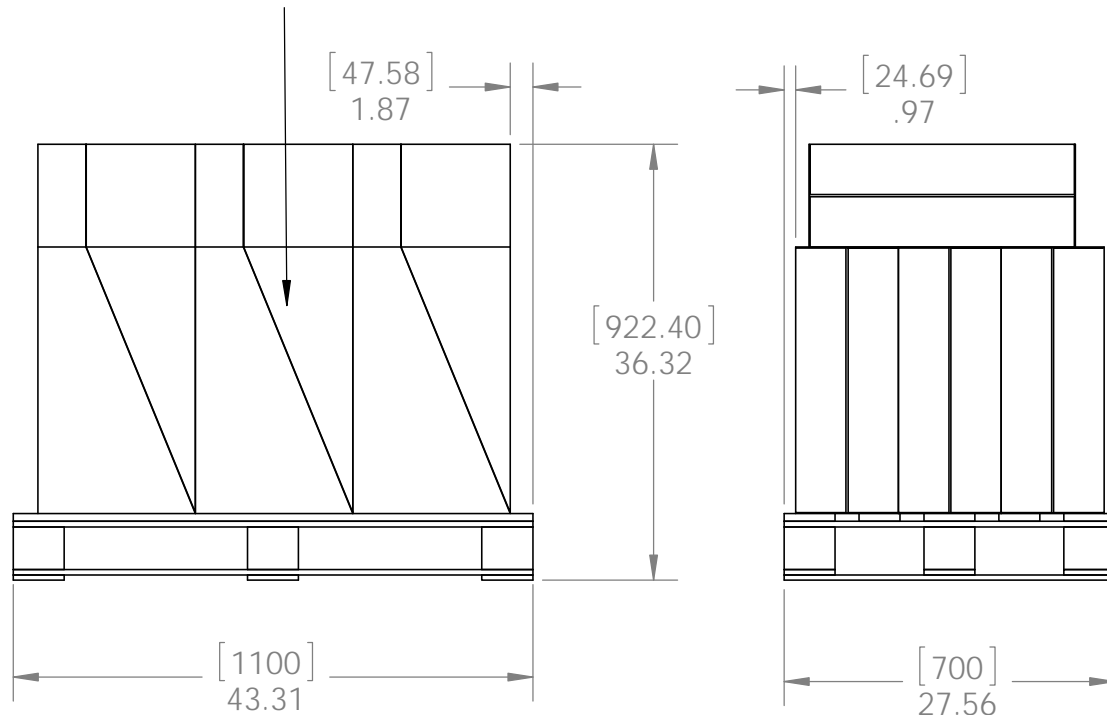

- additional pallet packing instructions
- plywood on top layer
 - strap to pallet
 - clear wrap around boxes

Weight: 237 LBS
 Scale: 1:16
 Last updated: 7/13/2015