

Product & Packaging Specs

Assembly, Post to Beam Bolt Offset

Item #: 56636

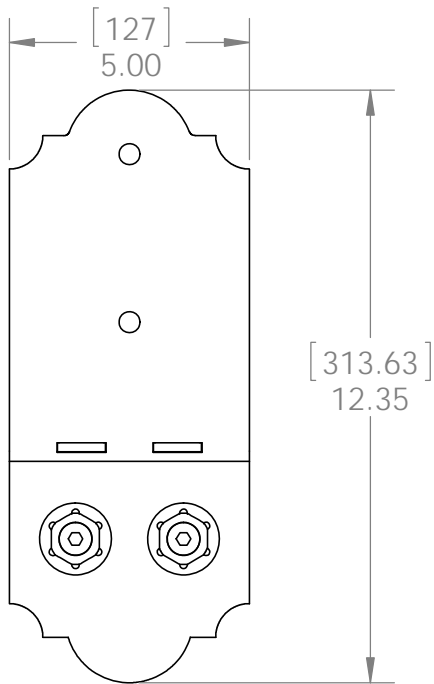
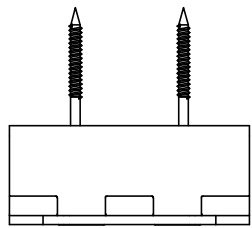

ITEM NO.	QTY.	PART NUMBER	DESCRIPTION
1	1	56636-11	Plate, Top Bolt Offset
2	1	56610-11	Ledge, Post to Beam
3	2	56621	1 1/2" Hex Cap Nut
4	0.08	56626	OWT Timber Screw 2-3/4"

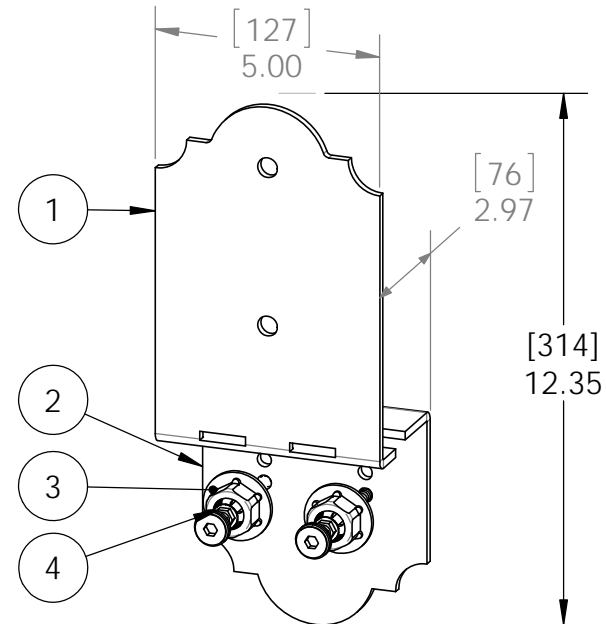

kit contains 2 assemblies

Weight: 45.05 LBS
 Scale: 1:4
 Last updated: 7/13/2015

Product & Packaging Specs

Assembly, Post to Beam Bolt Offset

Item #: Typical Installation & Basic Assembly

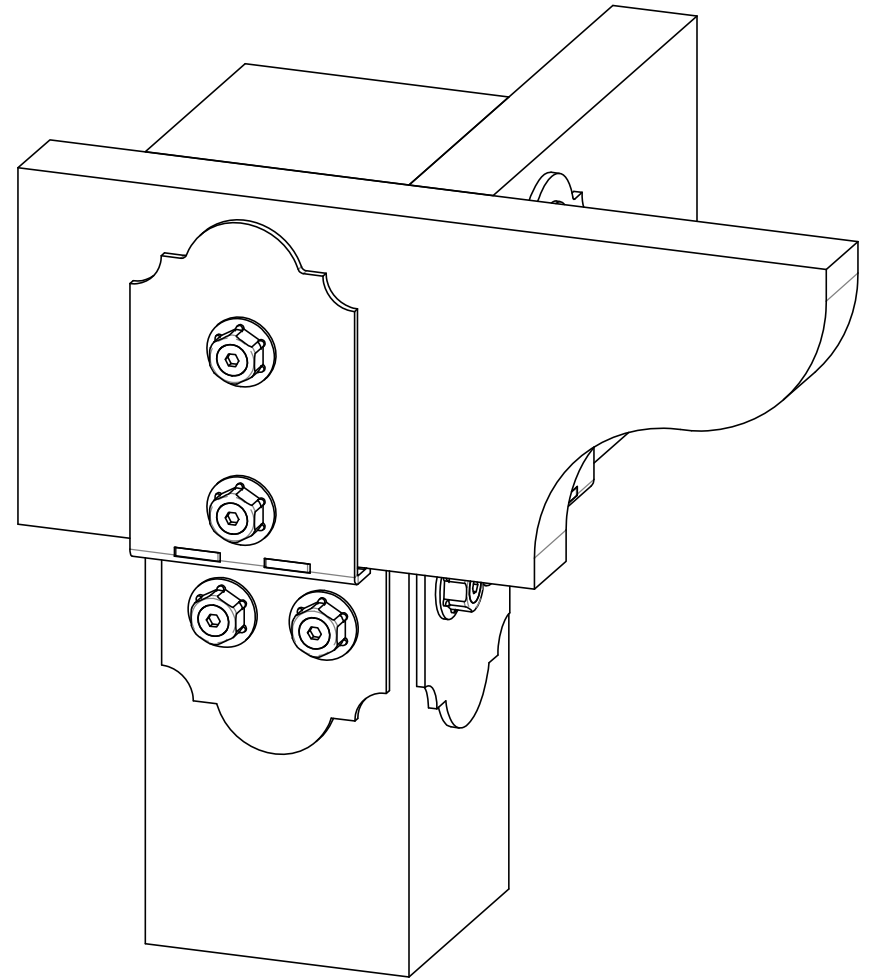
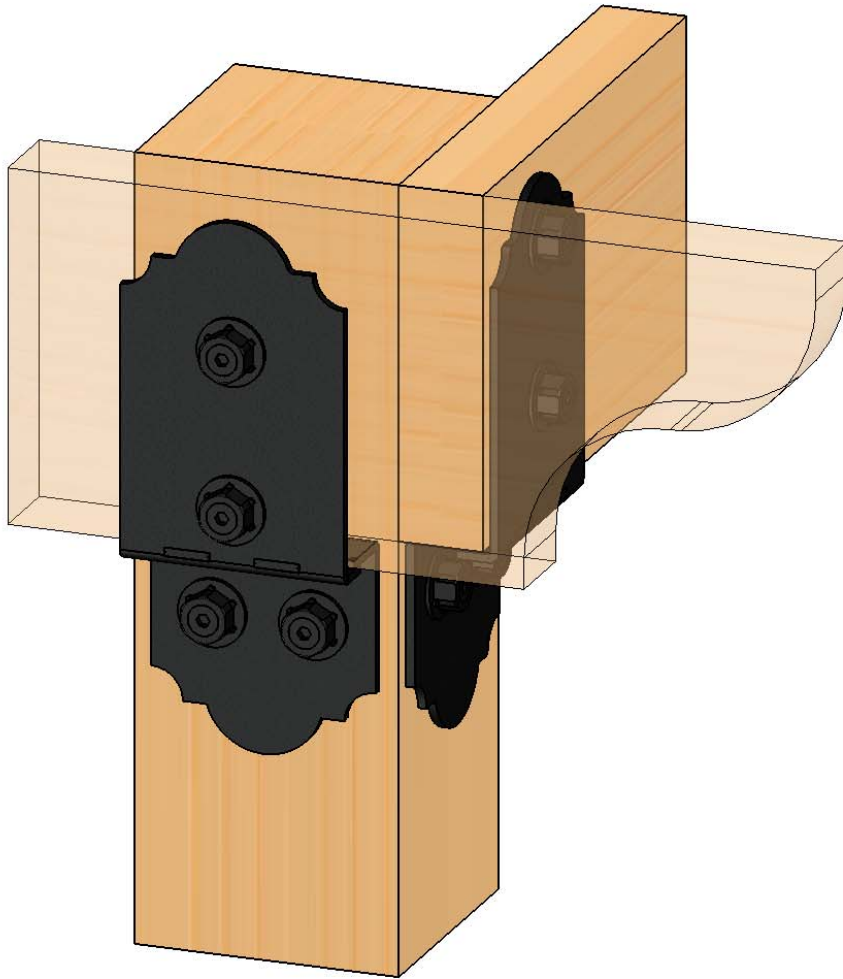

Weight: 45.05 LBS
Scale: 1:4
Last updated: 7/13/2015

56636-10

Product & Packaging Specs

Assembly, Post to Beam Bolt Offset

Item #: Typical Installation & Basic Assembly

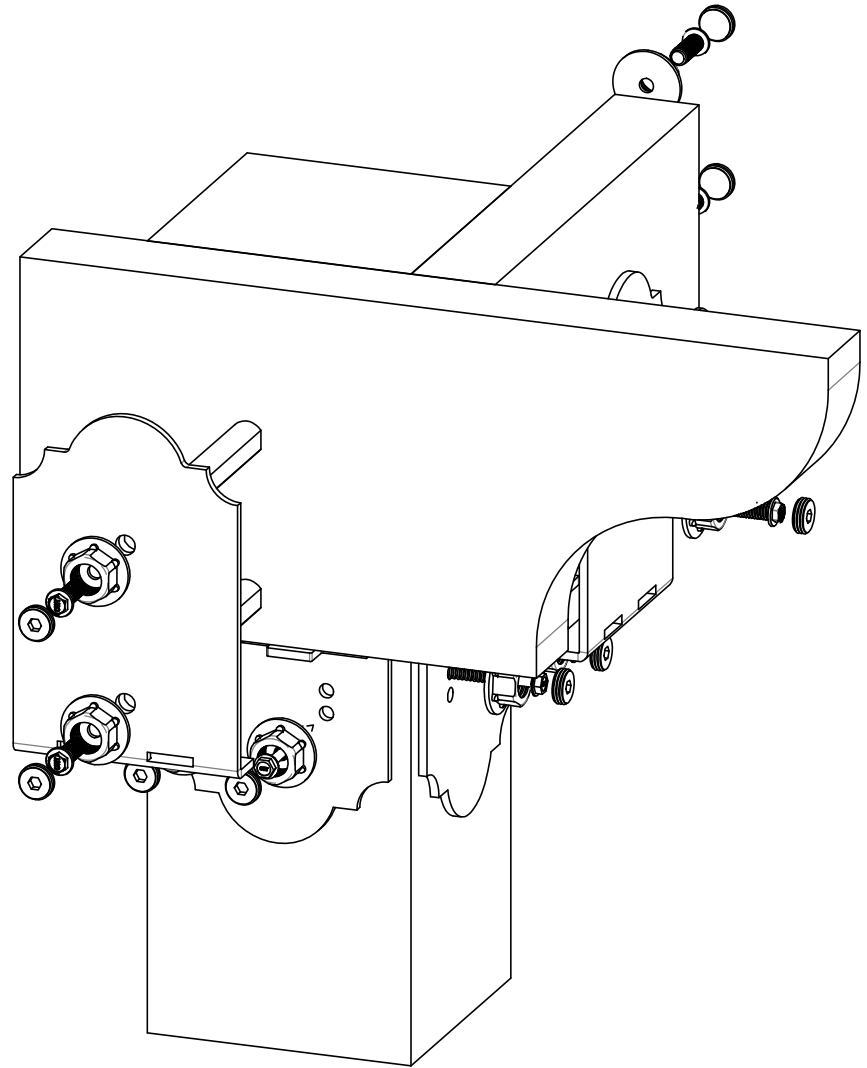
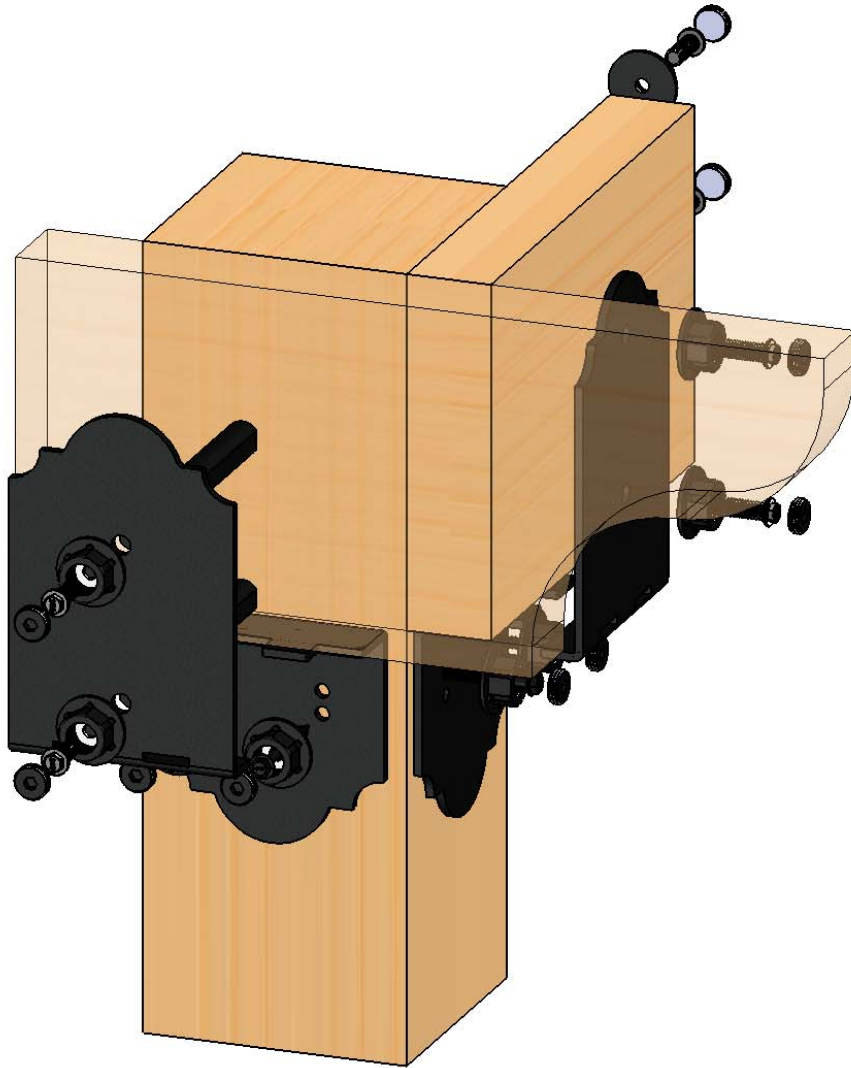

Weight: 45.05 LBS
Scale: 1:4
Last updated: 7/13/2015

56636-10



OZCO BUILDING PRODUCTS

Product & Packaging Specs

Box, Post to Beam

Item #: Box

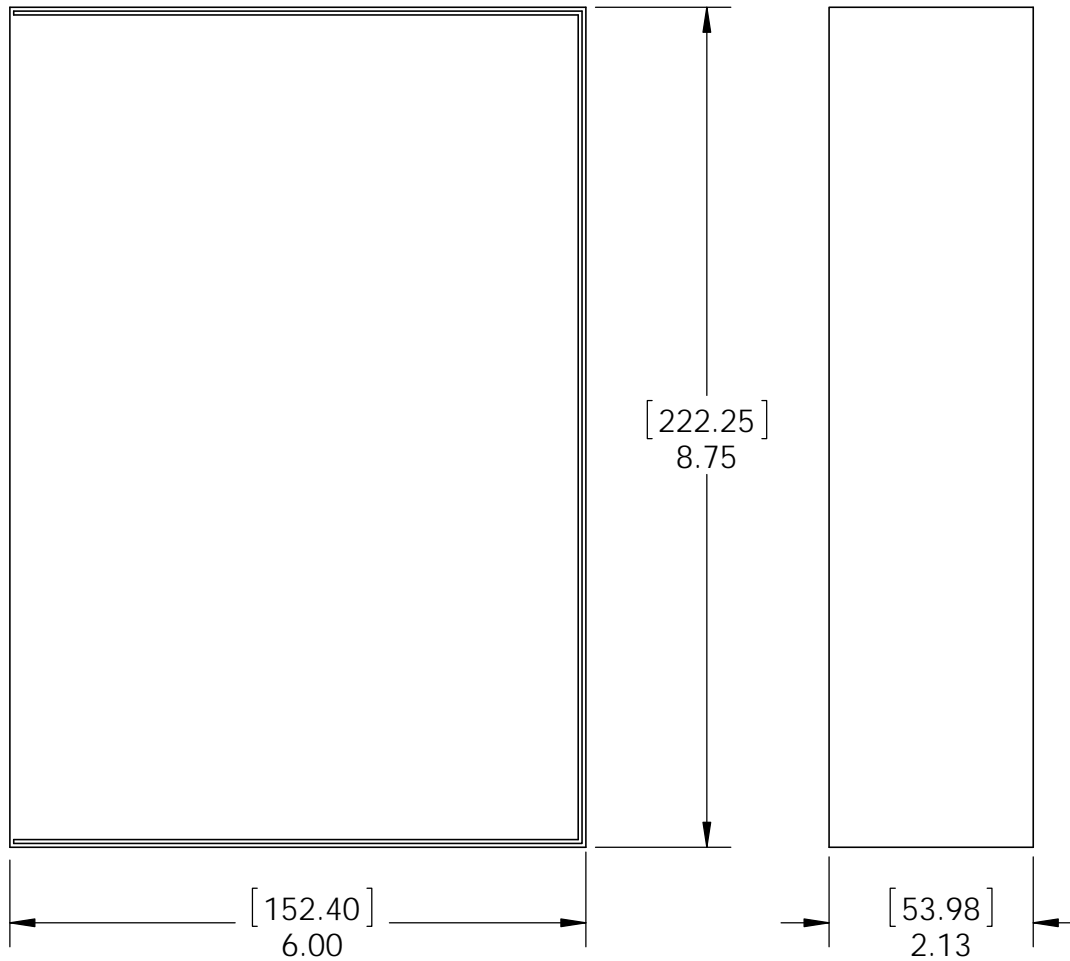

Material: Corrugated Paper
Finish: See Artwork
Weight: 0.04 LBS
Scale: 1:2
Last updated: 7/13/2015

56636-10



OZCO BUILDING PRODUCTS

Product & Packaging Specs

56636 Packing

Item #: Box packing

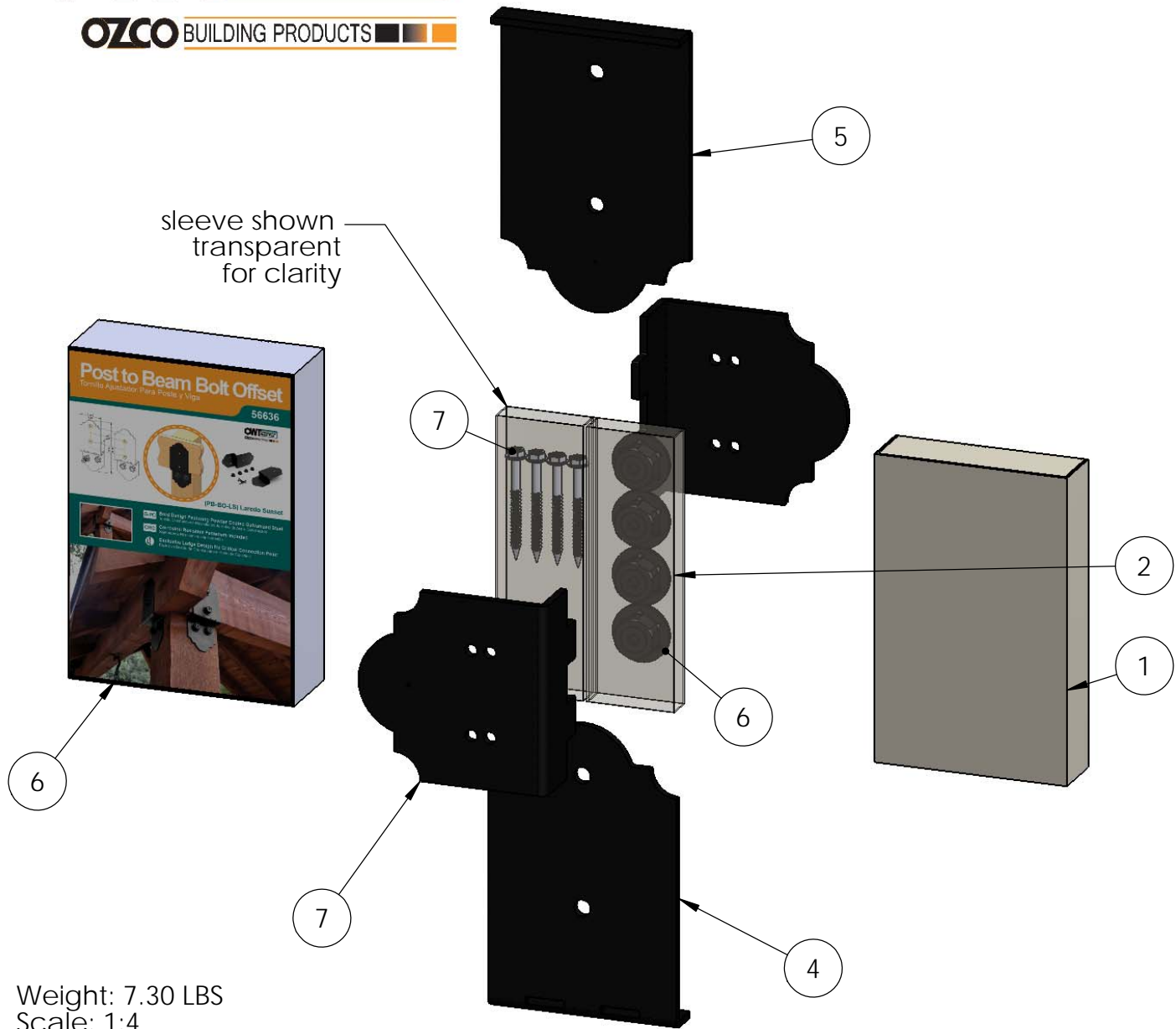

ITEM NO.	QTY.	PART NUMBER	DESCRIPTION
1	1	56637 Inner Box	Box, 56637 Inner
2	1	56637 Inner Box Sleeve	Sleeve, Post to Beam Inner Box
3	4	56626-10	OWT Timber Screw 2-3/4 (70mm)
4	1	56636-11	Plate, Top Bolt Offset
5	1	56637-11	Plate, Bolt Inline
6	1	56636 Box	Box, Post to Beam
7	2	56610-11	Ledge, Post to Beam
8	4	56621	1 1/2" Hex Cap Nut

Weight: 7.30 LBS
 Scale: 1:4
 Last updated: 7/13/2015

56636-10

Product & Packaging Specs

Case, Post to Beam Box

Item #: Case

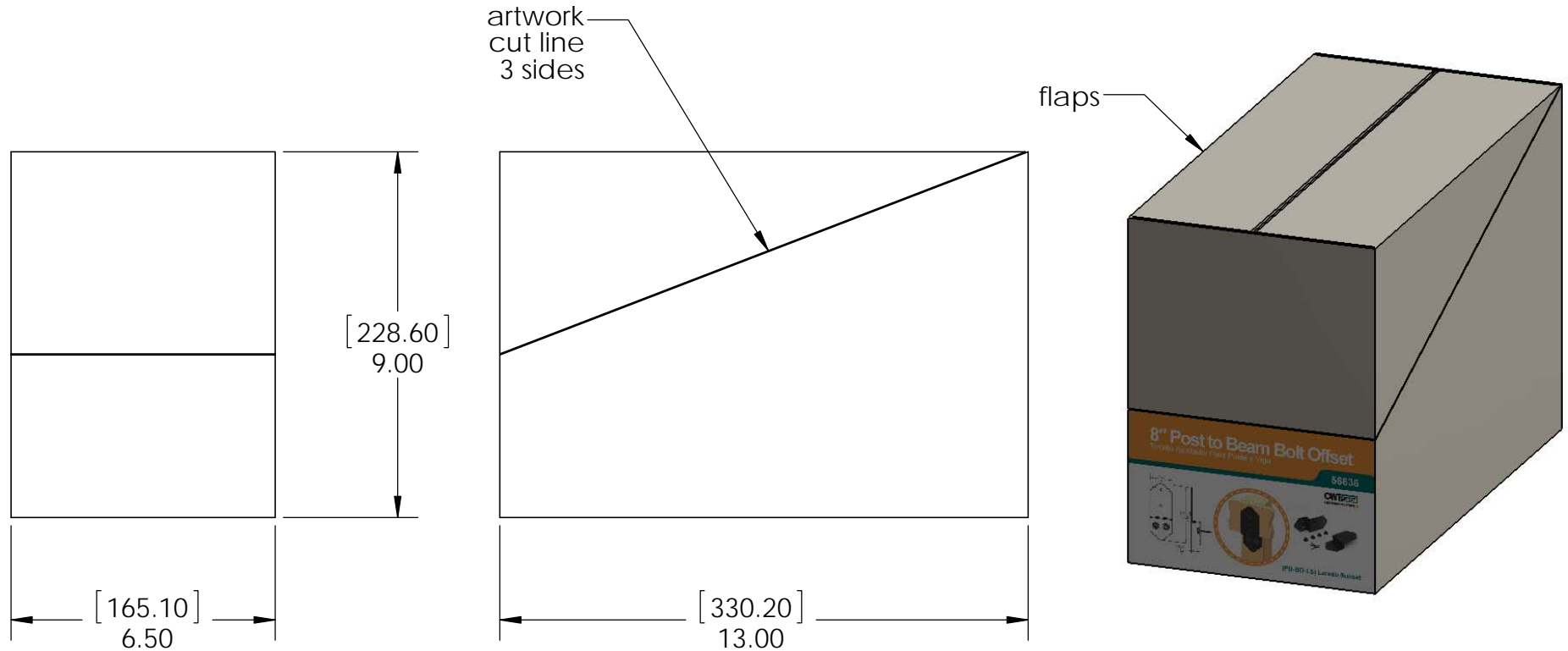

Material: Corrugated Paper
 Finish: Natural
 Weight: 0.23 LBS
 Scale: 1:4
 Last updated: 7/13/2015

56636-10

Product & Packaging Specs

56636 Packing

Item #: Case packing

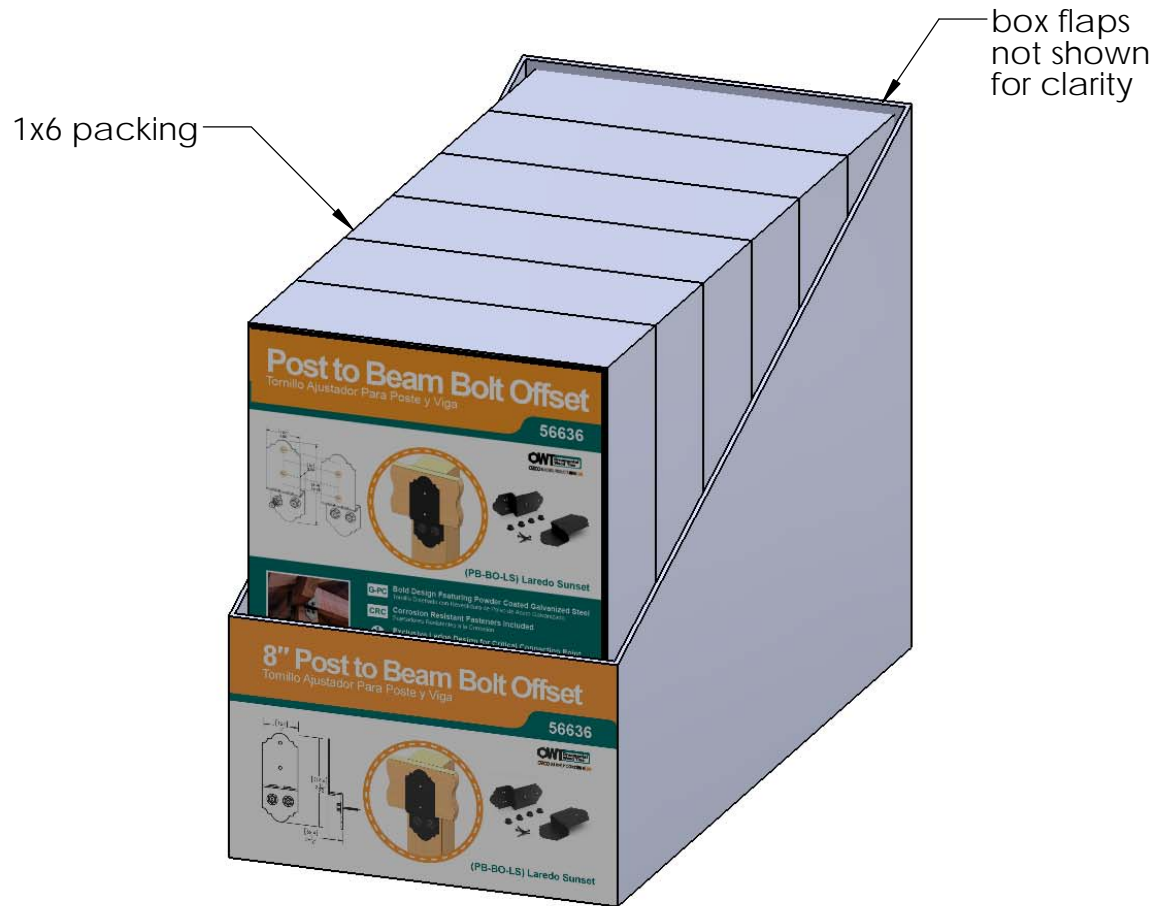

Weight: 45 LBS
 Scale: 1:3
 Last updated: 7/13/2015

56636-10

Item #: **56636** | **P2B-BO-LS**

Post to Beam Offset LS

PALLET **168 pcs**

SKU#: 56836



Weight: 1340 lbs

LOT# _____ Priority# _____

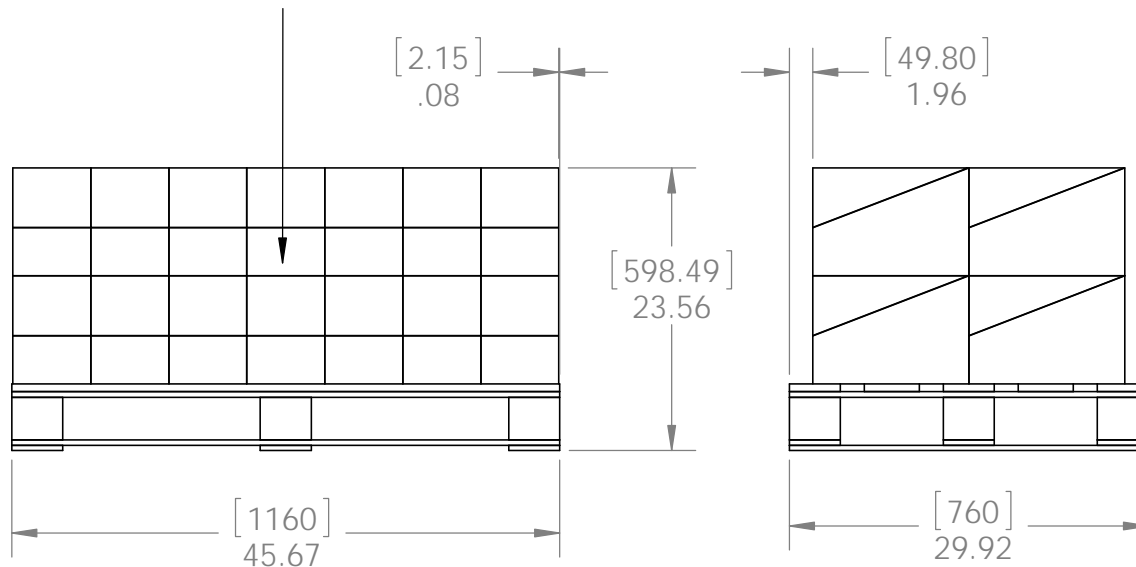

Total number of cases: 28
 Total number of pieces:
 28x6=168 pieces on pallet

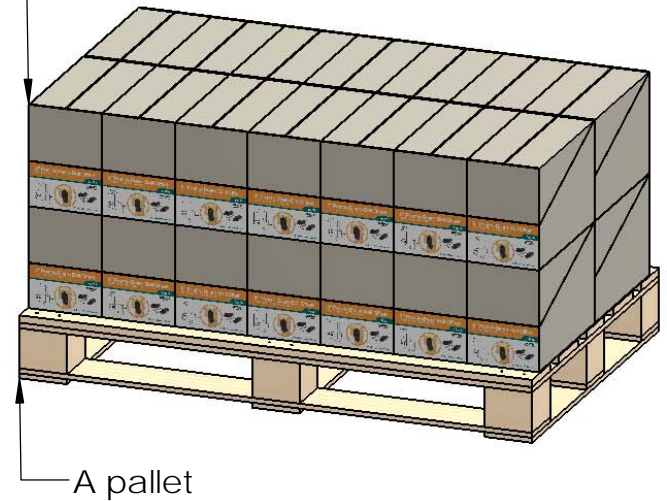

additional pallet packing instructions

- plywood on top layer
- strap to pallet
- clear wrap around boxes

Weight: 1340 LBS
 Scale: 1:16
 Last updated: 7/13/2015