



OZCO BUILDING PRODUCTS

Product & Packaging Specs

2" High Velocity Rafter Clip

Item #: 56638

ITEM NO.	QTY.	PART NUMBER	DESCRIPTION
1	1	56638-11	2" High Velocity Rafter Clip
2	6	80014	Screw, FHP #12 X 1.25", Black

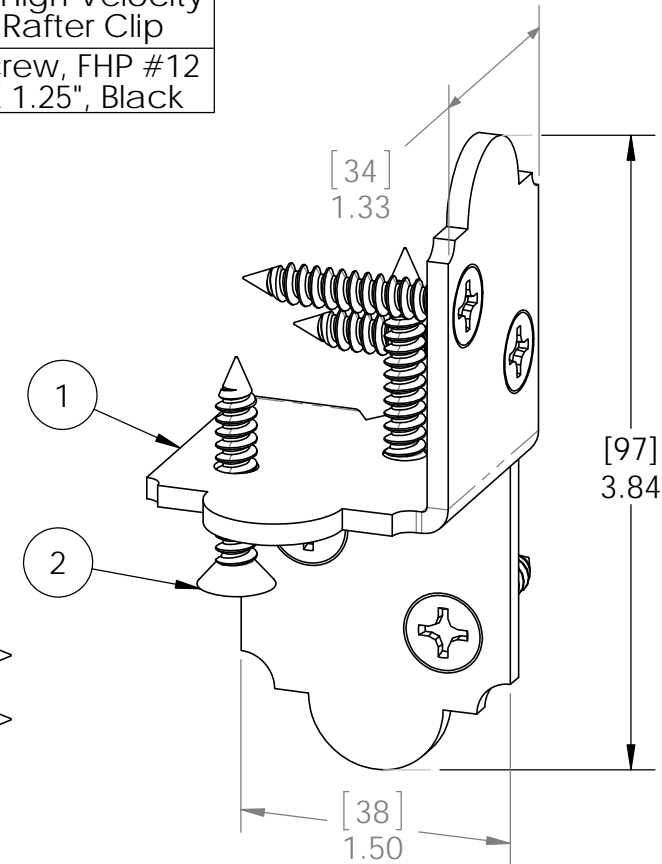
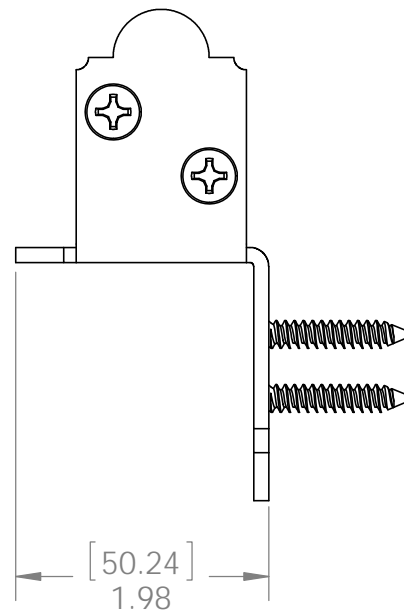
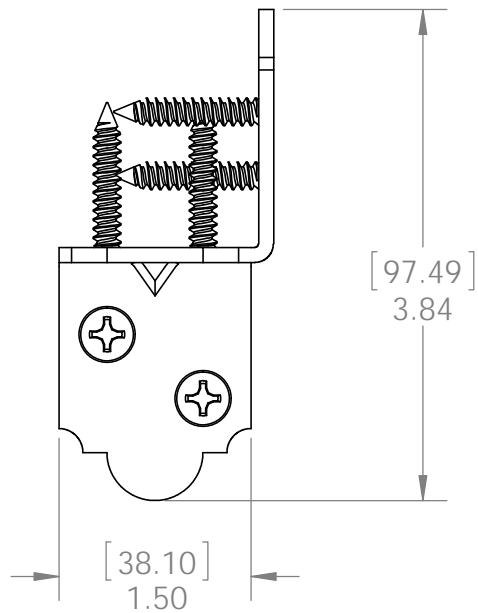
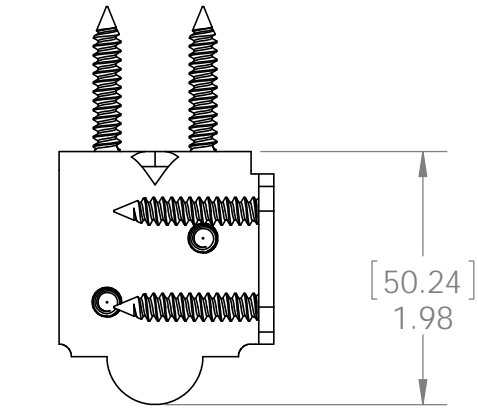

Weight: 0.86 LBS
 Scale: 1:1.5
 Last updated: 7/13/2015

revision B corrects #10 screws to #12

Product & Packaging Specs

2" High Velocity Rafter Clip

Item #: 56638

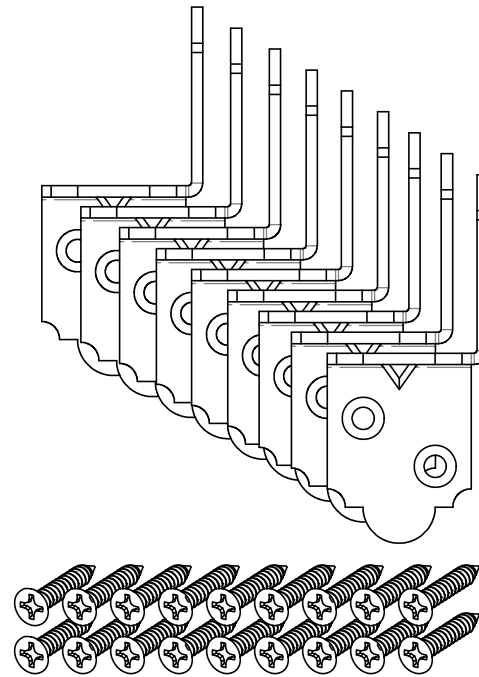
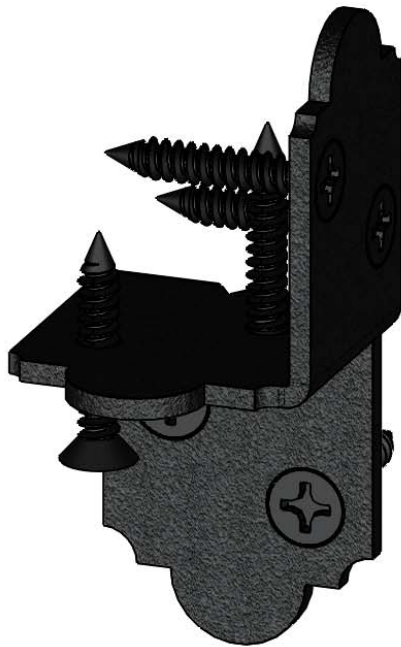

Weight: 0.86 LBS
Scale: 1:2
Last updated: 7/13/2015

revision B corrects #10 screws to #12

Product & Packaging Specs

2" High Velocity Rafter Clip

Item #: Typical Installation & Basic Assembly

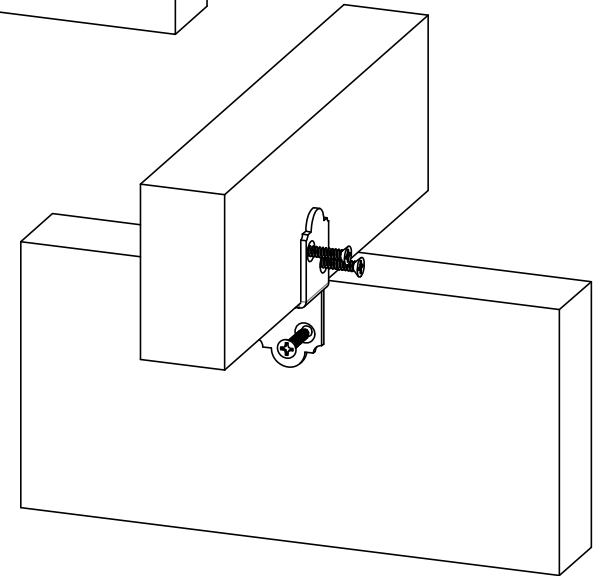
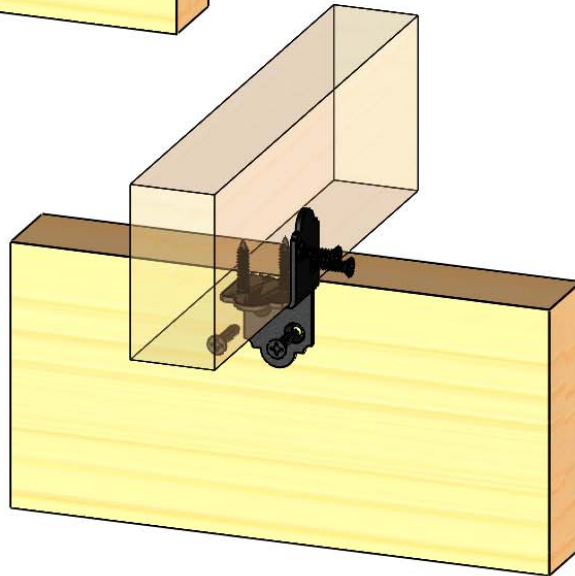
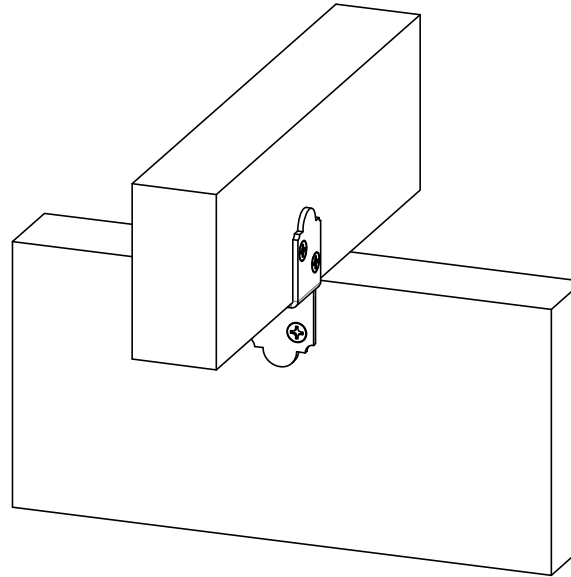
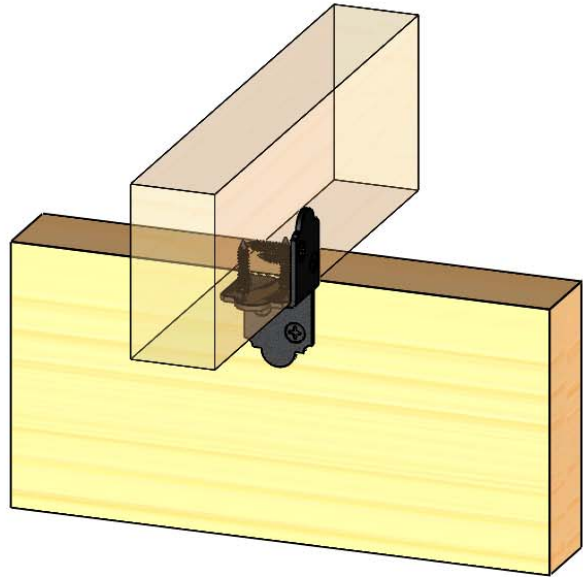

Scale: 1:4
Last updated: 7/13/2015

Product & Packaging Specs

Box, 6-8" Joist Hanger

Item #: Box

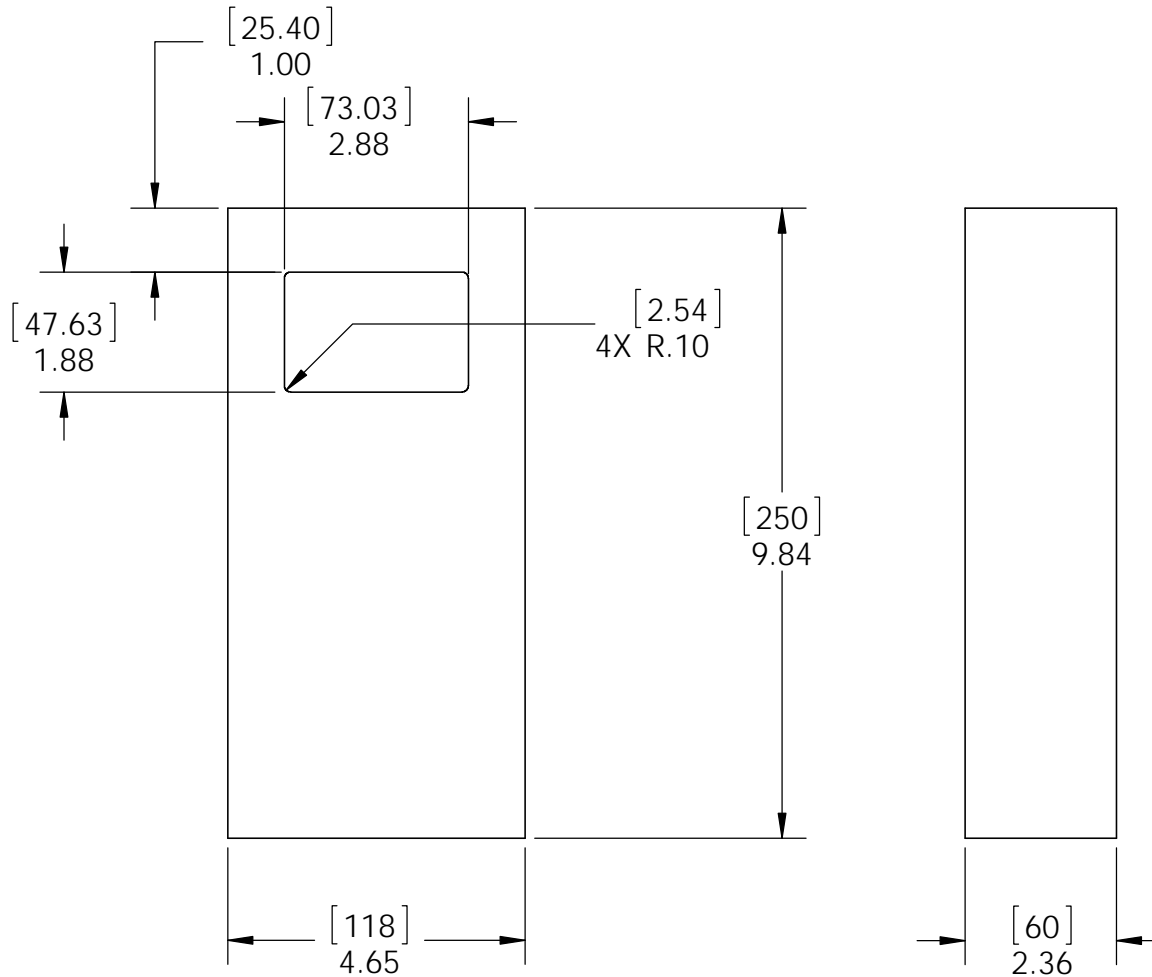

Material: Corrugated Paper
 Finish: See Artwork
 Weight: 0.03 LBS
 Scale: 1:3
 Last updated: 7/13/2015

56638-10



OZCO BUILDING PRODUCTS

Product & Packaging Specs

56638 Packing

Item #: Box packing

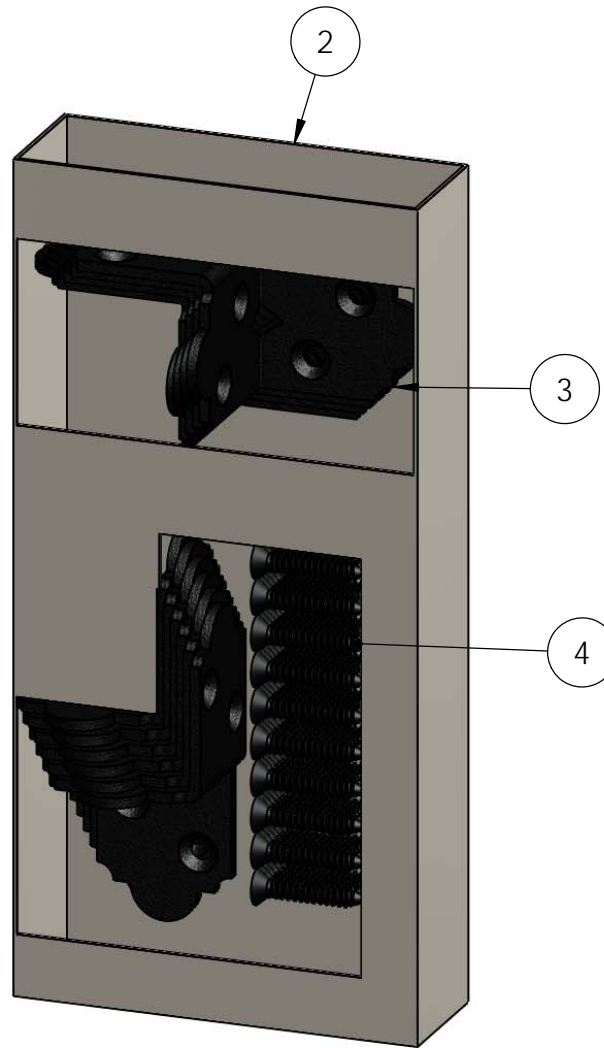

ITEM NO.	QTY.	PART NUMBER	DESCRIPTION
1	1	56638 Box	Box, 6-8" Joist Hanger
2	1	56638 Box Insert	Insert, 56638
3	10	56638-11	2" High Velocity Rafter Clip
4	60	80014	Screw, FHP #12 X 1.25", Black

screws shall be placed in plastic bag and packed as shown

Weight: 1.37 LBS
 Scale: 1:2
 Last updated: 7/13/2015

56638-10

revision B corrects #10 screws to #12

V1.00 - Installation Instructions effective May 1, 2015 and reflects information that available as of April 10, 2014. This information is updated periodically and should not be relied upon after May 1, 2015. Please visit www.OZCOBP.com to get current information

Product & Packaging Specs

Case, 56638

Item #: Case

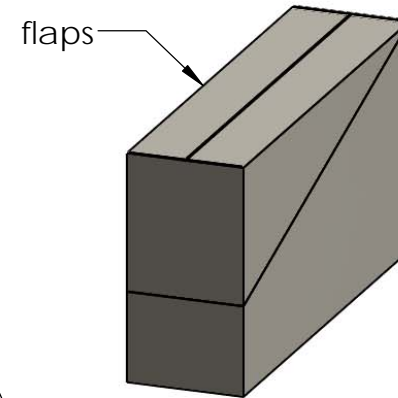

artwork
scoreline
3 sides

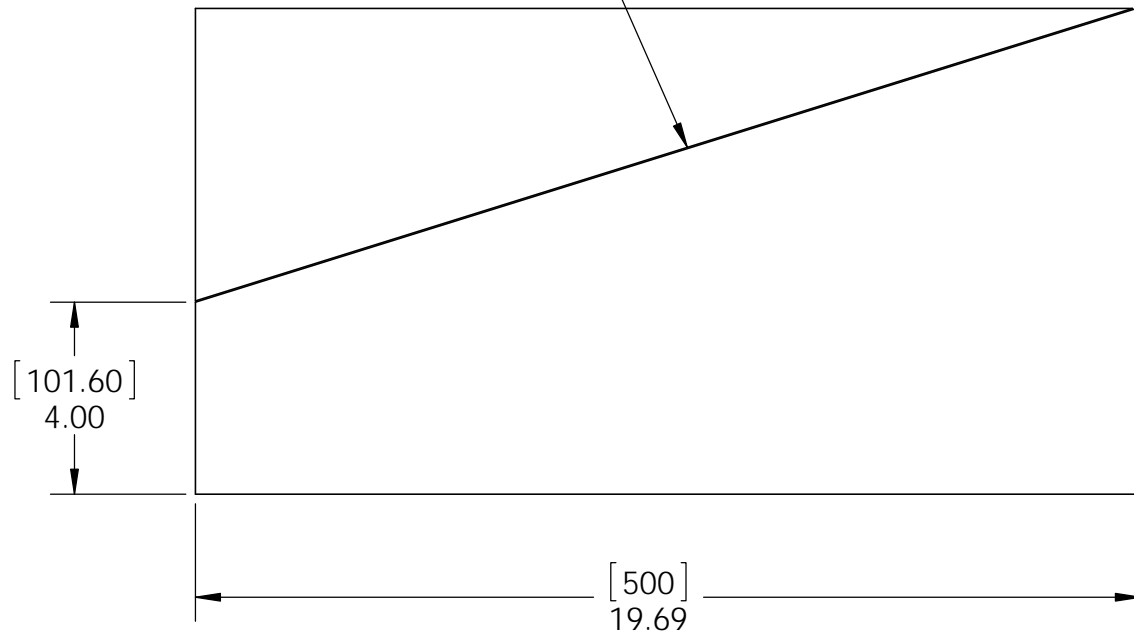
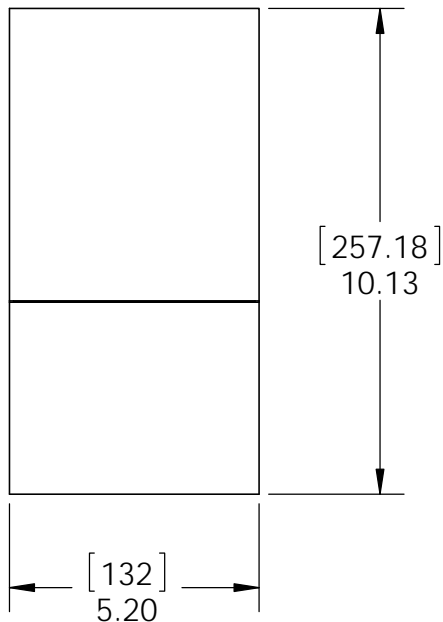

Material: Corrugated Paper
 Finish: See Artwork
 Weight: 0.31 LBS
 Scale: 1:4
 Last updated: 7/13/2015

56638-10

Product & Packaging Specs

56638 Packing

Item #: Case packing

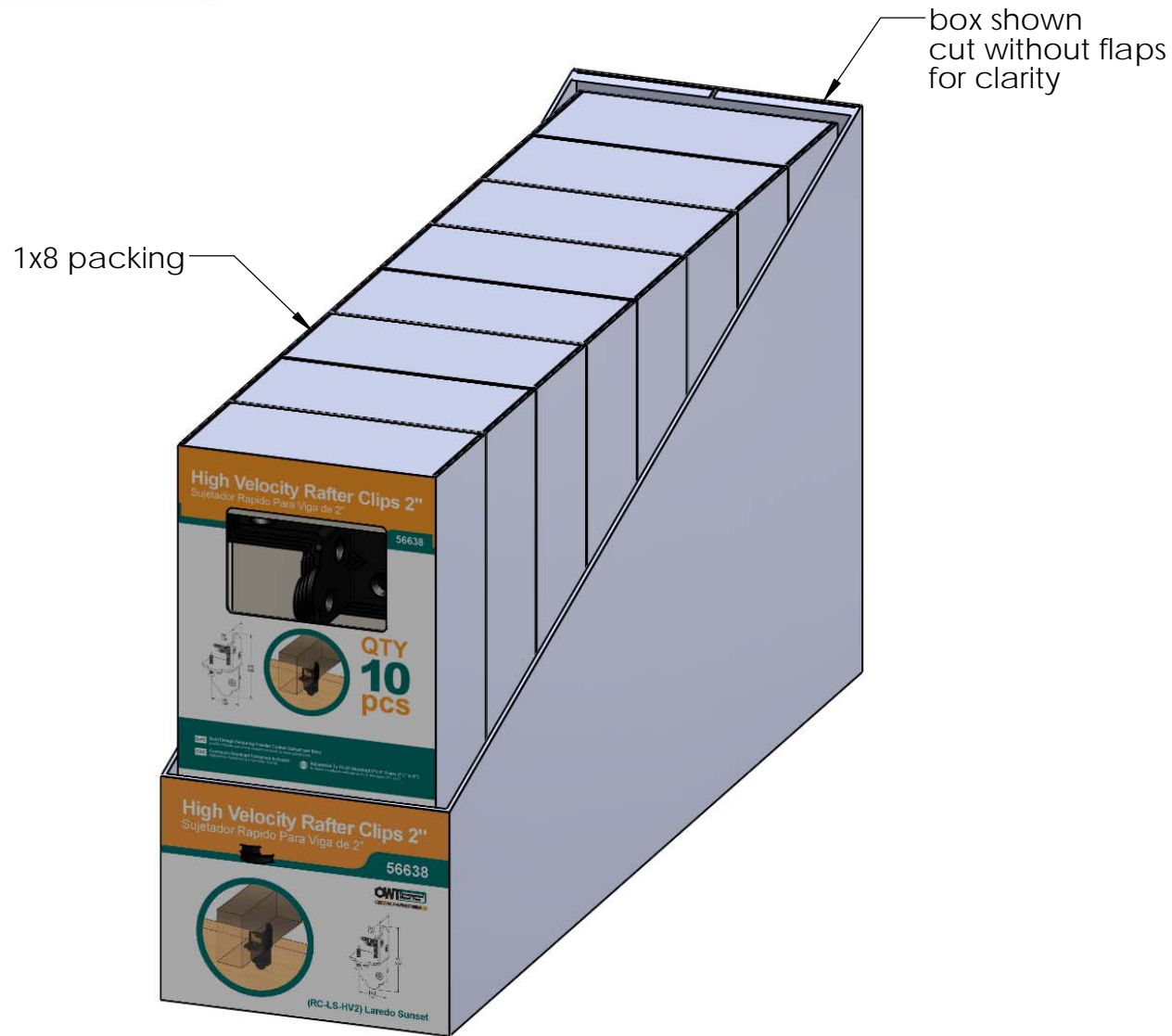

Weight: 22.15 LBS
Scale: 1:3
Last updated: 7/13/2015

56638-10

Item #: **56638** | **RC-LS-HV-2**
2" Rafter Clip HV LS
PALLET | **160 pcs**
SKU#: 56838 
Weight: 465 lbs
 LOT# _____ Priority# _____ 

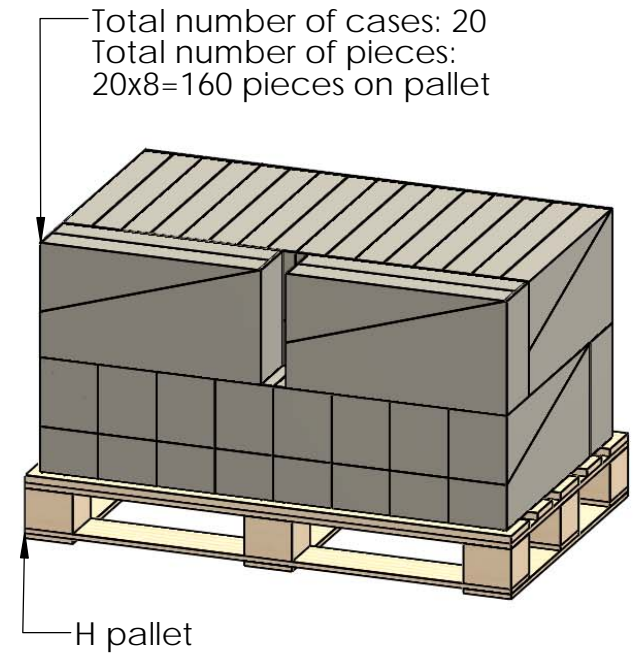
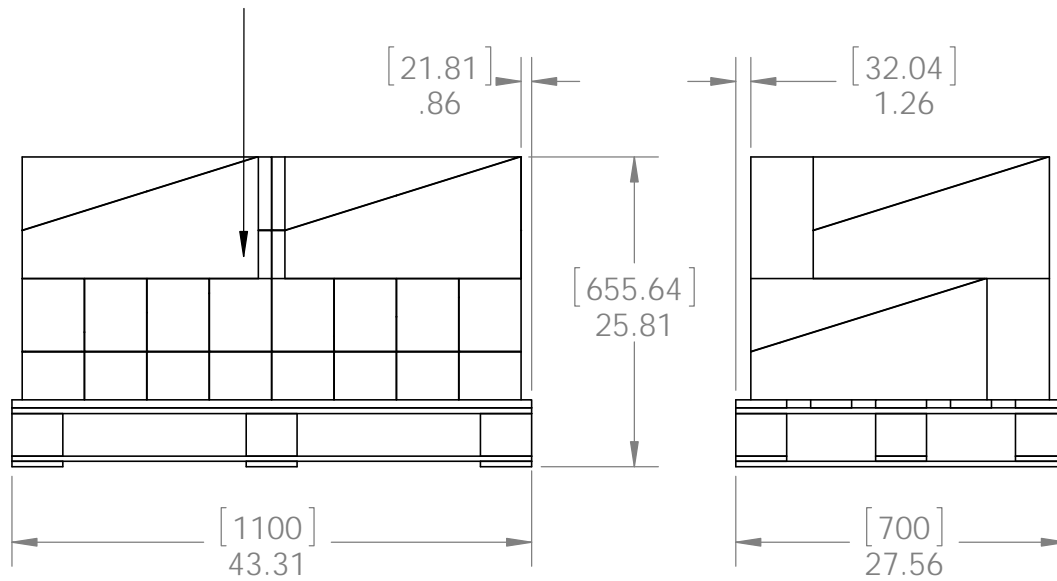

Total number of cases: 20
 Total number of pieces:
 20x8=160 pieces on pallet



- additional pallet packing instructions
- plywood on top layer
 - strap to pallet
 - clear wrap around boxes

Weight: 465 LBS
 Scale: 1:16
 Last updated: 7/13/2015

56638-10