

Product & Packaging Specs

Assembly, Strap Hinge

Item #: 56654

ITEM NO.	QTY.	PART NUMBER	DESCRIPTION
1	1	56655-12	Pin, Butterfly Hinge
2	2	56654-11	Bracket, Strap Hinge 1-1/4"
3	6	56622	Hammered Dome Cap Nut
4	6	56625	OWT Timber Screw 1-3/4"

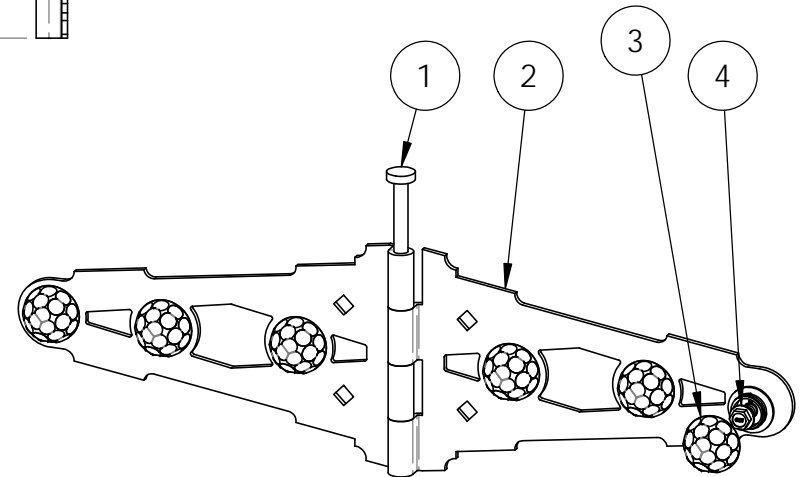
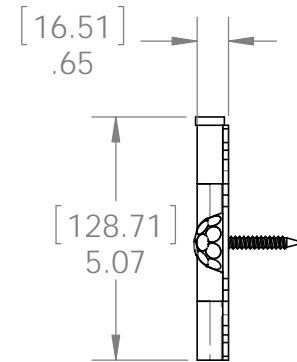
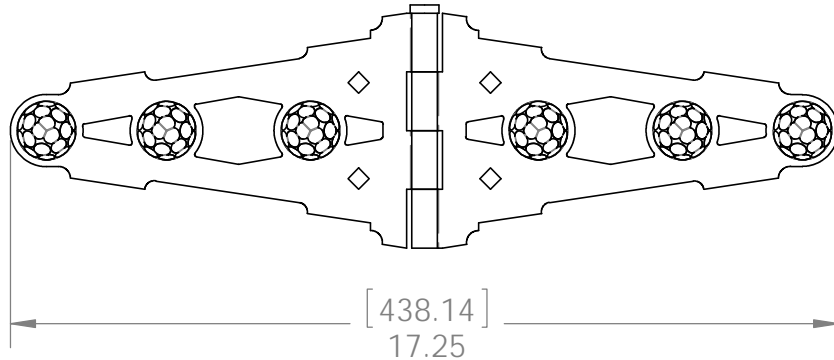

Weight: 1.99 LBS
 Scale: 1:2
 Last updated: 7/13/2015

Product & Packaging Specs

Assembly, Strap Hinge

Item #: 56654

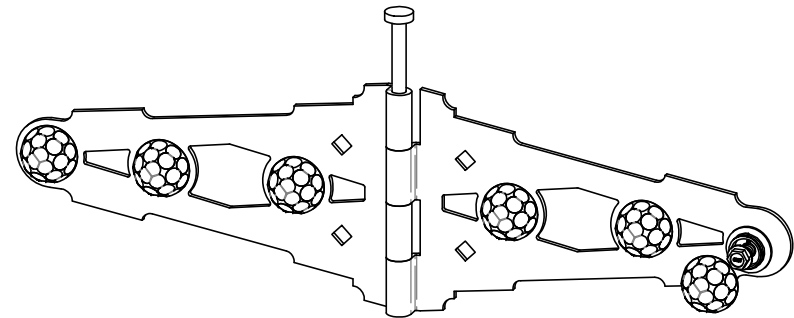
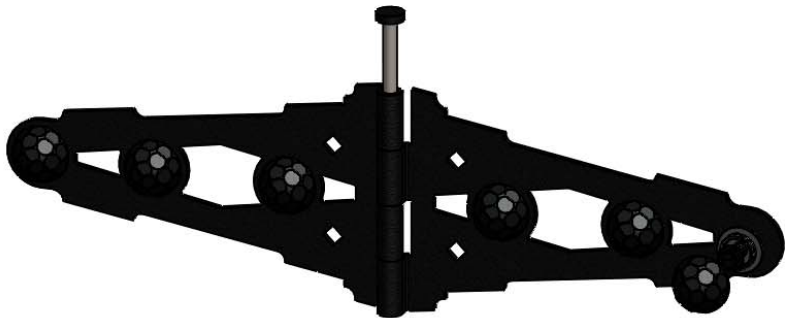
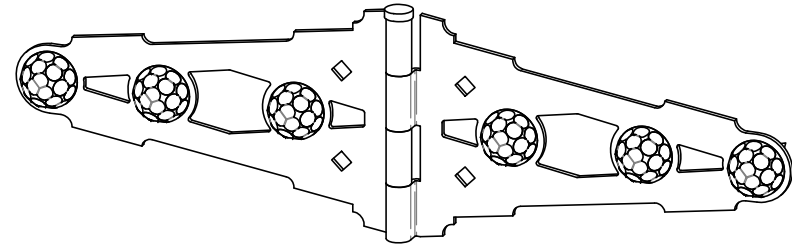
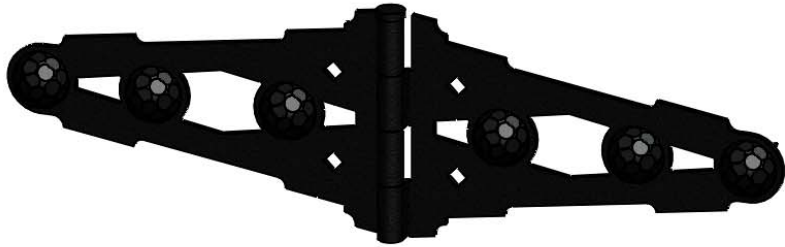

Weight: 1.99 LBS
Scale: 1:4
Last updated: 7/13/2015

56654-10

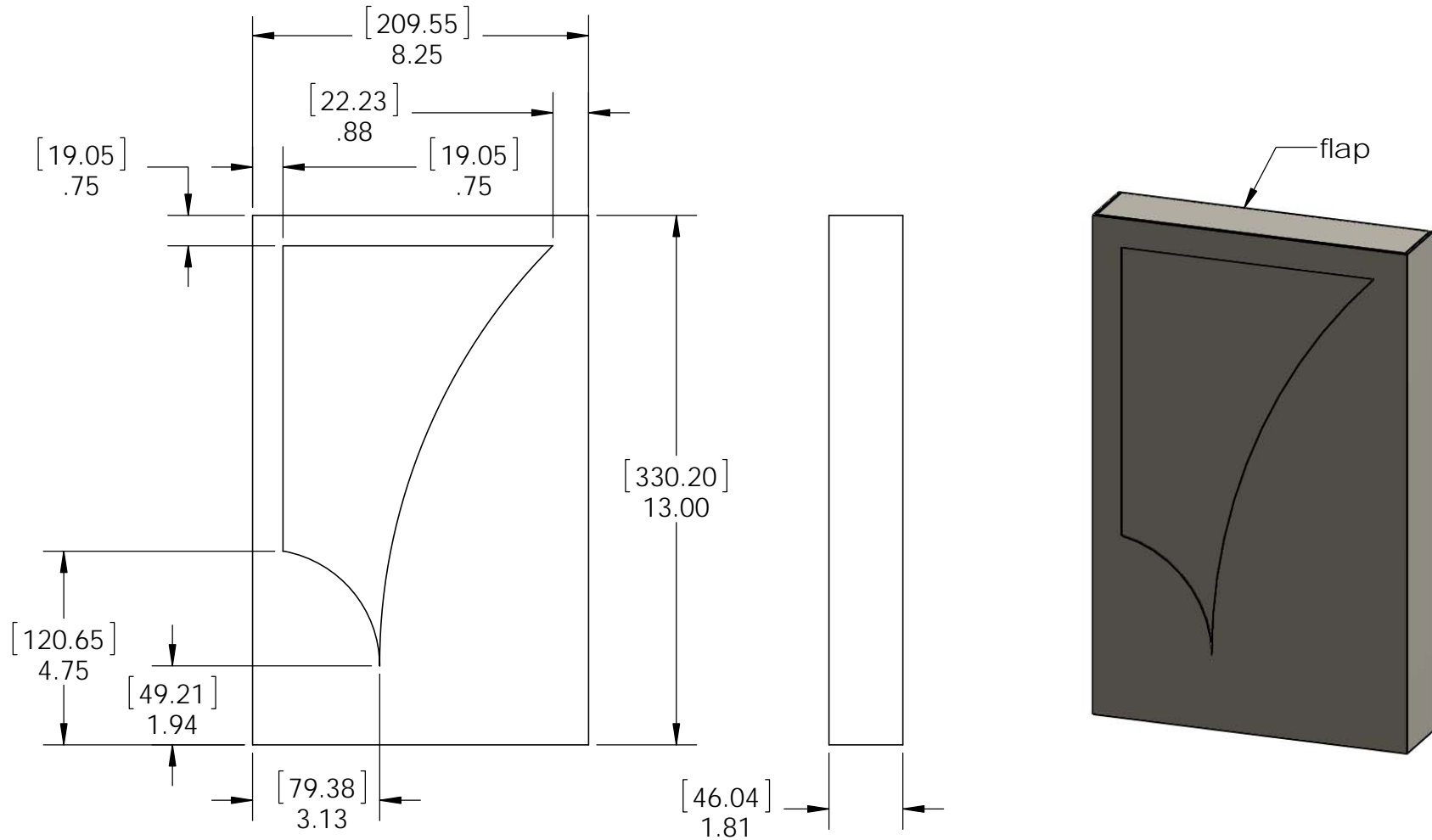

Material: Corrugated Paper
Finish: See Artwork
Weight: 0.06 LBS
Scale: 1:4
Last updated: 7/13/2015

56654-10

Product & Packaging Specs

56654 Packing

Item #: Box packing

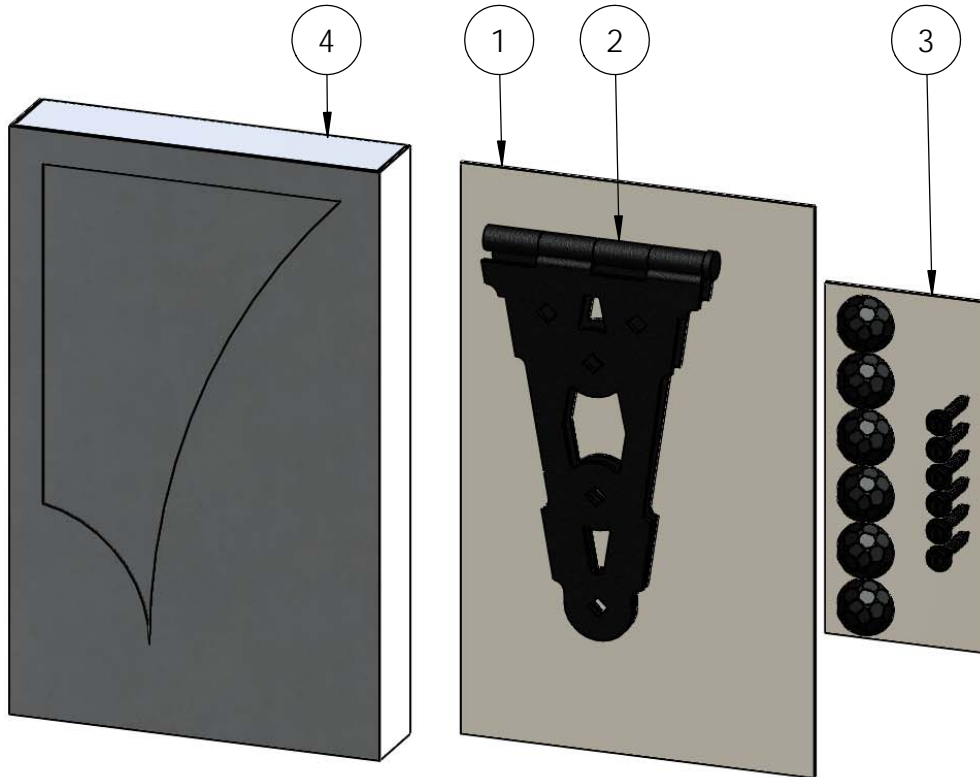

ITEM NO.	QTY.	PART NUMBER	DESCRIPTION
1	1	Insert, 56654 Box, #1	Insert, 56654 Box, #1
2	1	56654-10	Assembly, Strap Hinge
3	1	Insert, 56654 Box, #2	Insert, 56654 Box, #2
4	1	Box, 56654 Packing	Box, 56654 Packing

- Screws shall be placed inside small bag and secured with tape to insert #2
- Dome Cap Nuts shall be placed inside small bag and secured with tape to insert #2
- Secure item 2 to insert #1 with black twist ties so product is visible in box cutout

Weight: 3.04 LBS
 Scale: 1:4
 Last updated: 7/13/2015

56654-10

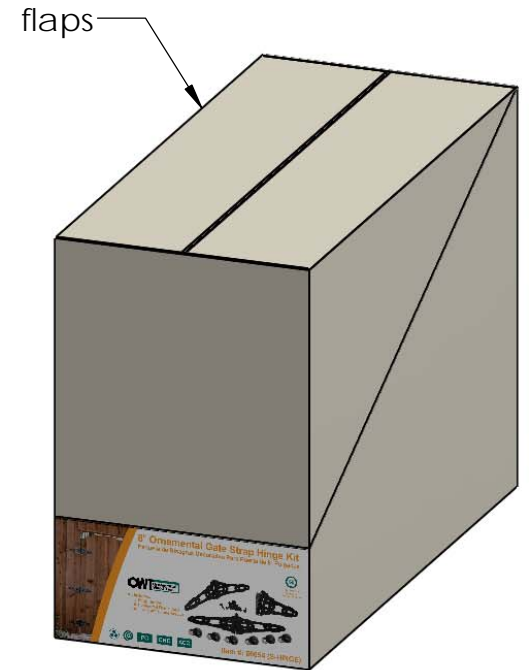
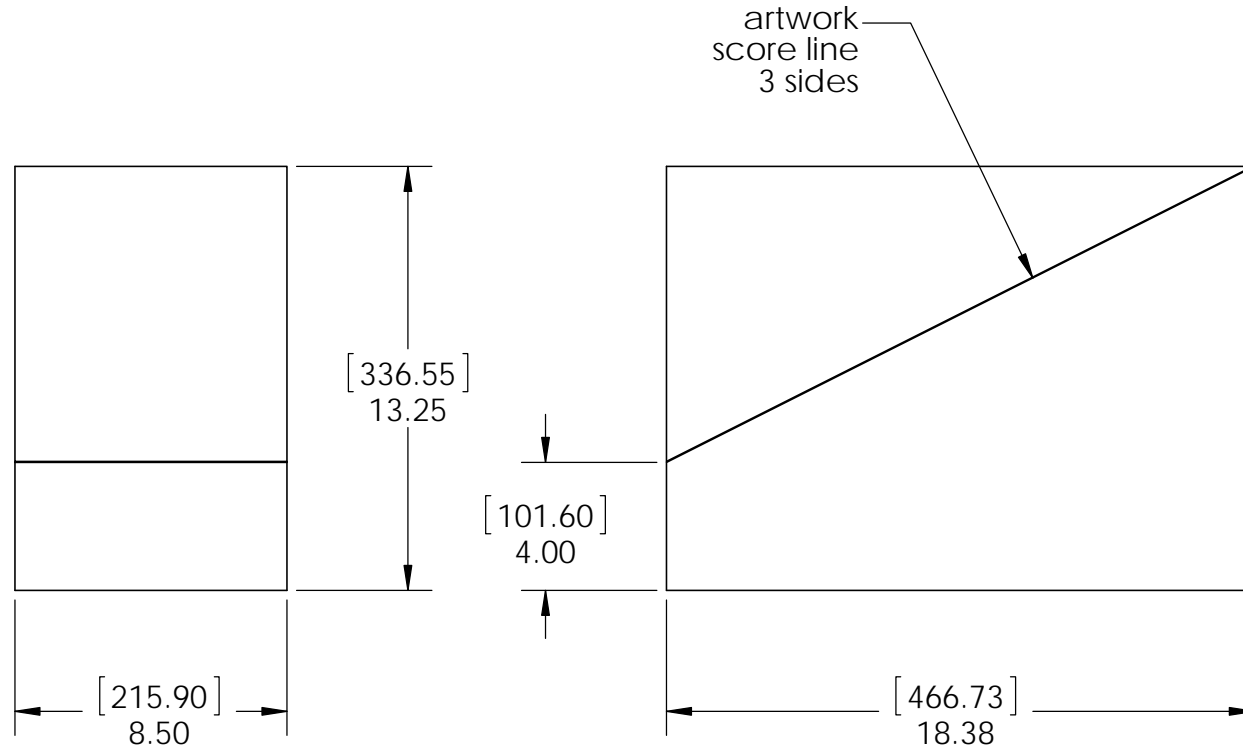

Material: Corrugated Paper
 Finish: Natural
 Weight: 0.45 LBS
 Scale: 1:6
 Last updated: 7/13/2015

56654-10

Product & Packaging Specs

56654 Packing

Item #: Case packing

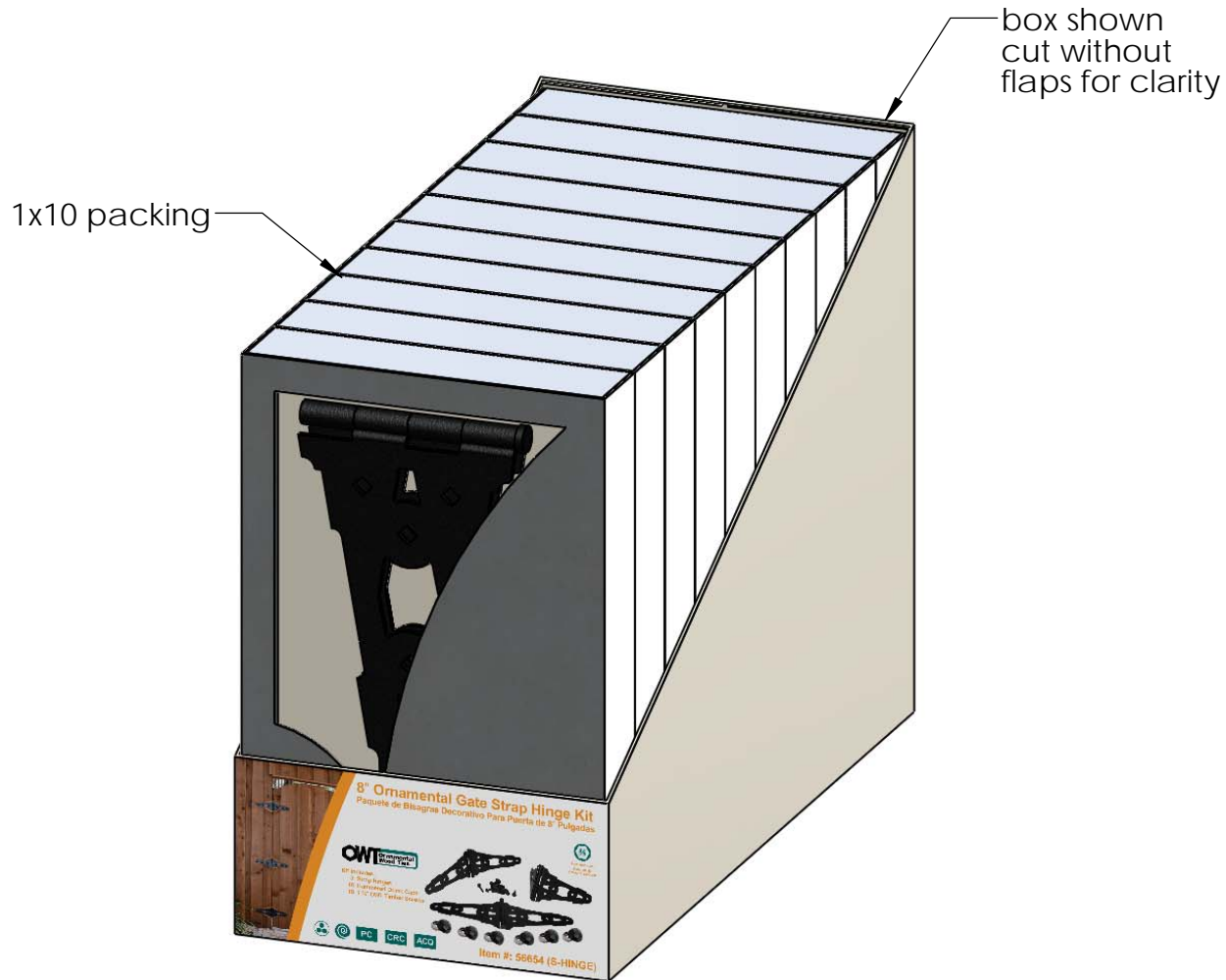

Weight: 32 LBS
Scale: 1:4
Last updated: 7/13/2015

56654-10

Item #: **56654** | **S-HINGE**
 8" Ornamental Gate Strap Hinge
PALLET 140 pcs
 SKU#: **56854** 
 Weight: **858 lbs**
 LOT# Priority# 

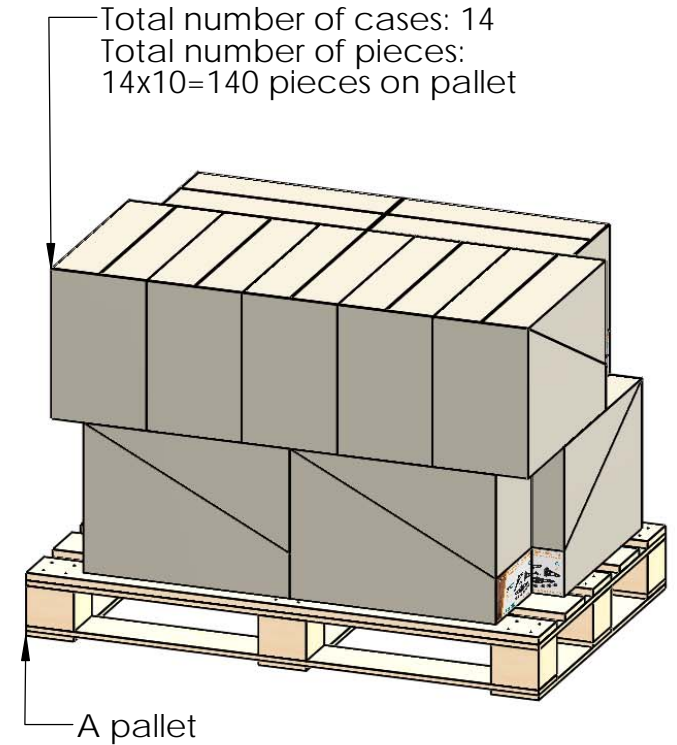
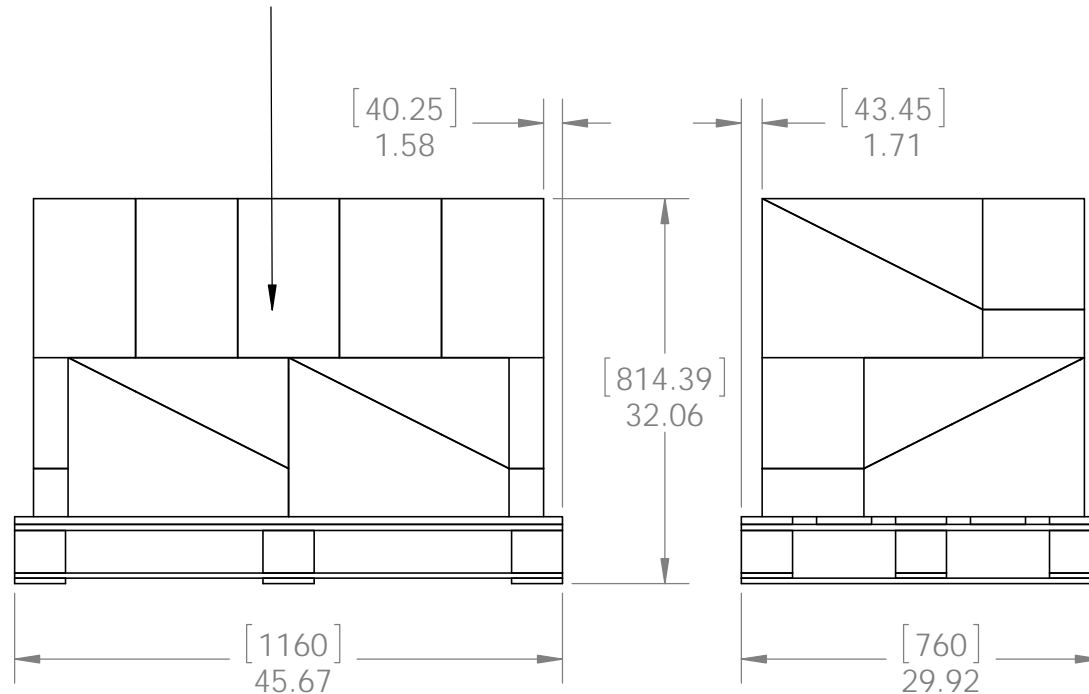

additional pallet packing instructions

- plywood on top layer
- strap to pallet
- clear wrap around boxes

Weight: 858 LBS
 Scale: 1:16
 Last updated: 7/13/2015