



## Code Compliance Research Report

CCRR-0213

Subject to Renewal: 08/01/2015

Visit [www.archtest.com](http://www.archtest.com) for current status

Issued: 08/01/2014

Page 1 of 10

**Key Link Fencing & Railing, Inc.**  
150 Orlan Road  
New Holland, Pennsylvania 17557  
(717) 355-7139  
[www.keylinkfencing.com](http://www.keylinkfencing.com)

### 1.0 Subject

#### Aluminum Railing Systems

*Keystone Series*  
*American Series*  
*Arabian Series*

### 2.0 Research Scope

#### 2.1. Building Codes:

2012 International Building Code (IBC)  
2012 International Residential Code (IRC)

#### 2.2. Properties:

Structural Performance

### 3.0 Description

3.1. General – The aluminum railing systems are guards or guardrails under the definitions of the referenced codes. They are intended for use at or near the open sides of elevated walking areas of buildings and walkways as required by the codes.

3.2. Guard Assemblies – Guards are provided as level guards for level walking areas such as decks, balconies, and porches. Level guards are provided with rail lengths up to 96 inches in length (measured between the inside of support posts) and an installed height of 42 inches. See Table 1 for qualified configurations.

3.3. Materials and Processes – The aluminum railing systems are an assemblage of extruded aluminum materials, extruded poly vinyl chloride (PVC) baluster retainers, stainless steel fasteners, and cast aluminum bracket materials.

3.3.1. The system is available in various colors and architectural grade powder coated finishes.

3.4. Components - The guardrail system includes a top rail, a top rail subassembly, a bottom rail, a baluster retainer in each rail, vertical balusters, a welded structural post, rail-to-post brackets, and decorative moldings and post caps.

3.4.1. Rails - Each of the top and bottom aluminum rails are routed to accept 0.75 inch square infill components described in Section 3.4.2 for the various railing systems as shown in Figure 1 through Figure 4.

3.4.1.1. The top rail caps are extruded 6105-T6 aluminum rails 1.75 inches wide by 0.95 - 1.03 inches tall. The top rail caps snap onto a 1.25 inch wide by 1.50 inch tall 6105-T6 aluminum sub rail assembly. A PVC rail insert is used as a baluster retainer. See Figure 2 through Figure 4.

3.4.1.2. The bottom rails are extruded 6105-T6 aluminum rails are 1.25 inches wide by 1.50 inches tall. A PVC rail insert is used as a baluster retainer. See Figure 2 through Figure 4.

3.4.2. The infill area for all styles is configured with 6063-T4 or 6063-T52 aluminum balusters. See Figure 11 through Figure 18.

3.4.3. Structural support posts are hollow square 6063-T6 and 6005-T5 aluminum extrusions with 0.125 inch walls. The extrusions are welded to square aluminum base plates. See Figure 19 through Figure 21.

### 4.0 Performance Characteristics

4.1. The guardrail system described in this report has demonstrated the capacity to resist the design loadings specified in Chapter 16 of both the IBC and Section R301 of the IRC when tested in accordance with ICC-ES AC273.

### 5.0 Installation

The guardrail system shall be installed in accordance with the Key Link Fencing & Railing, Inc.'s installation instructions and this report. Where differences occur between this report and Key Link Fencing & Railing, Inc.'s installation instructions, this report shall govern.

5.1.1. The top and bottom rails are attached directly to structural posts utilizing cast aluminum mounting brackets via mechanical fasteners. See Table 2 and Figure 5 through Figure 9.

5.2. Guards may be assembled in various configurations. Refer to Figure 1 through Figure 4 for overall assembly and Table 2 for the fastening schedule.

5.3. Infill components (aluminum balusters) are inserted into routed holes in the aluminum rails and secured via PVC baluster retainers that are installed internally to the rails. See Figure 1 through Figure 4, and Figure 11 through Figure 18.

5.4. Shim plates are utilized under the base of the structural post. The hardware used to anchor the base of the structural post to the supporting structure is installed so that it passes through the concave corners of the shim plates. Shim plates are 0.055 inch thick 304 stainless steel plates. See Figure 10.

## 6.0 Supporting Evidence

6.1. Drawings and installation instructions submitted by Key Link Fencing & Railing, Inc.

6.2. Reports of testing demonstrating compliance with the performance requirements of ICC-ES AC273, Acceptance Criteria for Handrails and Guards, effective March 1, 2008. AC273 addresses requirements of the IBC and IRC.

6.3. A quality control manual that is in accordance with the ICC-ES AC10, *Acceptance Criteria for Quality Documentation*, effective January, 2014.

## 7.0 Conditions of Use

The guard assemblies identified in this report are deemed to comply with the intent of the provisions of the referenced building codes subject to the following conditions.

7.1. Attachment of guardrail systems described herein to conventional wood supports is outside the scope of this report.

7.2. Shim plates must be used for all structural post installations as described in Section 5.4.

7.3. Anchorage of the structural post is not within the scope of this report and is subject to evaluation and approval by the building official. Anchors must satisfy the design load requirements specified in Chapter 16 of the building code and must meet the following minimum requirements:

7.3.1. A minimum of four anchor bolts must be used and located in the four pre-drilled holes in the structural post base plate.

7.3.2. The anchors must have a minimum nominal diameter equal to 3/8 inch.

7.3.3. When the supporting structure is a wood-framed deck, installation must include anchorage to suitable structural framing. Decking is not considered structural framing, and anchorage to decking alone is not an approved installation method.

7.3.4. Where required by the building official, engineering calculations and details shall be provided. The calculations shall verify that the anchorage and supporting structure complies with the building code for the type and condition of the supporting construction.

7.4. The 304 stainless steel shim plates are used to prevent direct contact between the structural post base plate and supporting structure. Compatibility of fasteners and other metallic components with the supporting structure, including chemically treated wood, is outside the scope of this report.

7.5. Key Link Fencing & Railing, Inc. is located in New Holland, Pennsylvania and operates in accordance with an approved quality control system that includes independent third party inspections by Architectural Testing, Inc.

**8.0 Identification**

The guardrail assemblies that are described in this report shall be identified with labeling on the individual components and/or the packaging such that the product is identifiable at the point of use. The label shall include at least the following information:

8.1. Name and/or trademark of Key Link Fencing & Railing, Inc.

8.2. The name and/or identifying mark of the independent inspection agency (Architectural Testing, Inc.).

8.3. The Architectural Testing Code Compliance Research Report mark and number (CCRR-0213).

**9.0 Code Compliance Research Report Use**

9.1. Approval of building products and/or materials can only be granted by a building official having legal authority in the specific jurisdiction where approval is sought.

9.2. Code Compliance Research Reports shall not be used in any manner that implies an endorsement of the product by Architectural Testing.

9.3. Reference to the Architectural Testing internet web site address at [www.archtest.com](http://www.archtest.com) is recommended to ascertain the current version and status of this report.

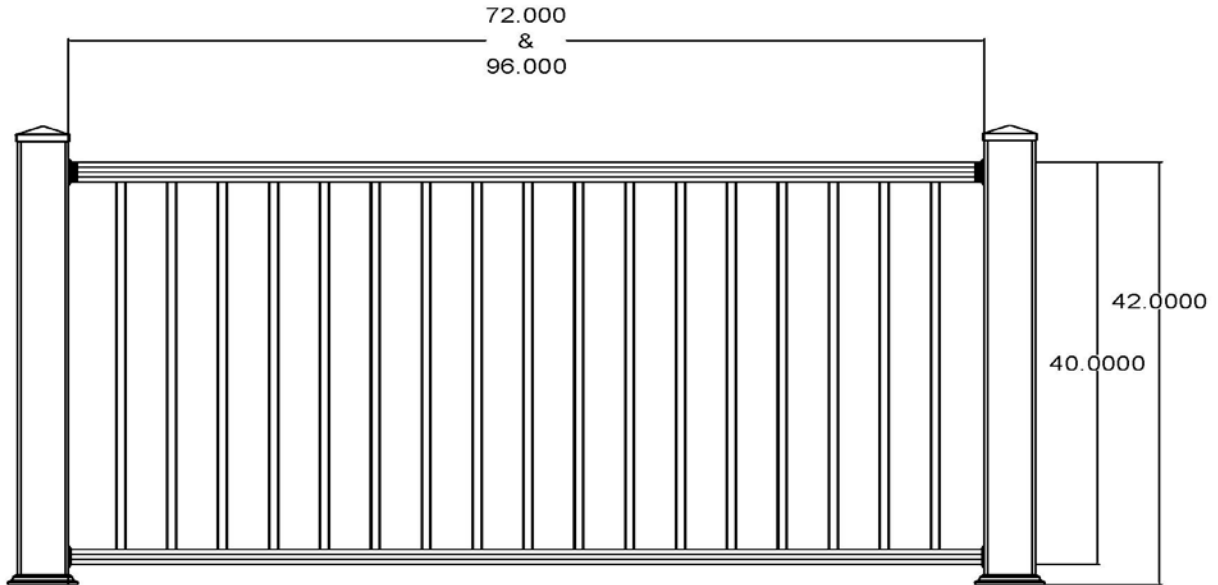
**Table 1**

<u>Keystone, American, and Arabian Aluminum Railing System Dimensions</u> <sup>1</sup>	<u>Guardrail Type</u>	<u>Post Type</u>	<u>Code Occupancy Classification</u>
96 in wide by 42 in high	Level	2-1/2" Post	<u>IRC</u> – One- and Two-Family Dwellings
72 in wide by 42 in high	Level	3-1/4" Post 4" Post	<u>IBC</u> – All Use Groups <u>IRC</u> – One- and Two-Family Dwellings

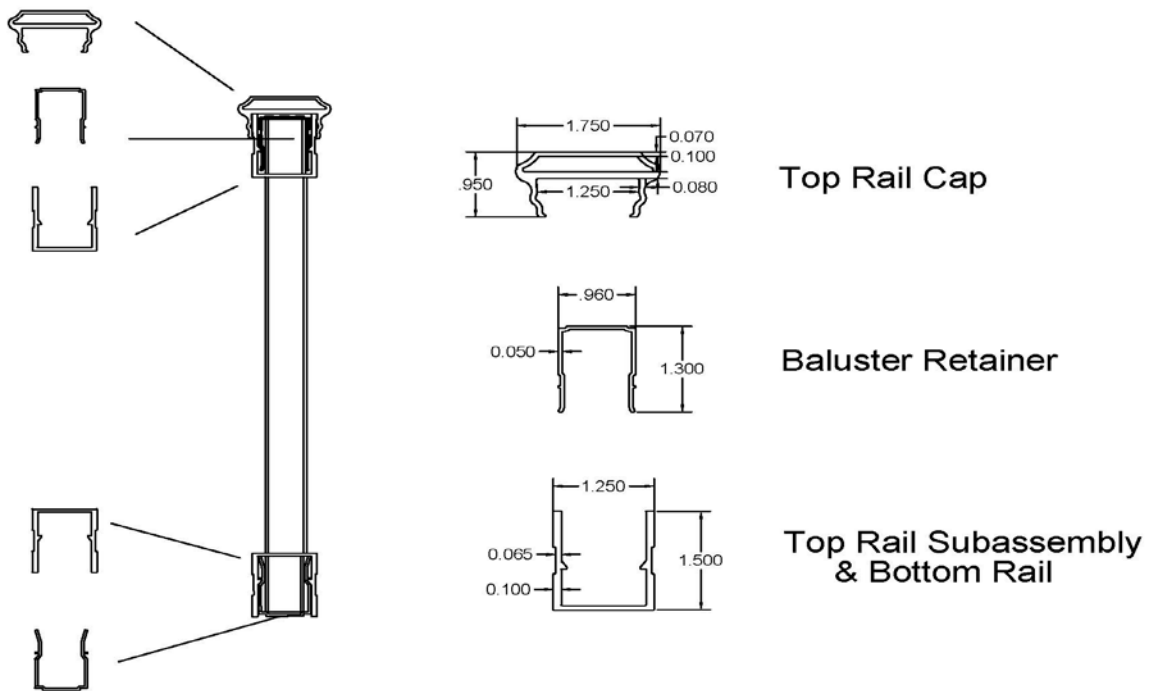
<sup>1</sup> Guardrails are qualified up to and including the listed maximum guardrail system dimensions for use in the referenced Code Occupancy Classification.

**Table 2**

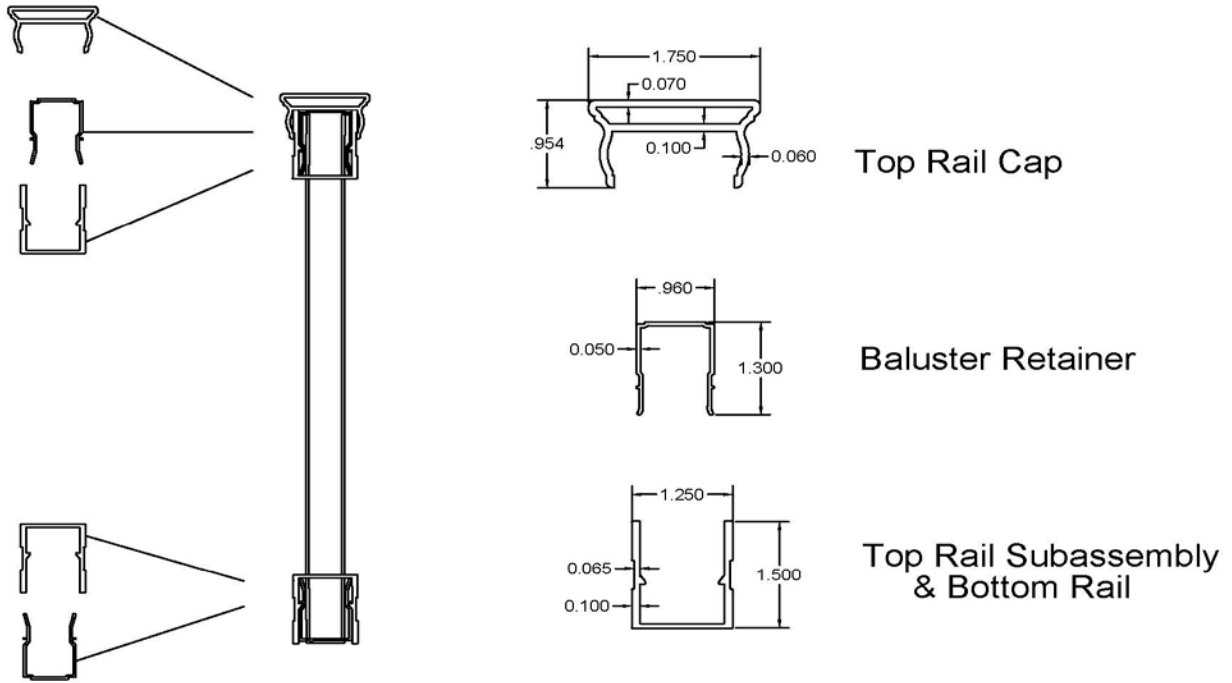
<u>Connection</u>	<u>Fastener</u>
All Rail Brackets to Post	Four #12 x 1" bevel-head, self-drilling, 304 stainless steel screws
Top Rail Bracket to Rail	Two #10 x 3/4" pan-head, self-drilling, 304 stainless steel screws
Bottom Rail Bracket to Rail	No mechanical fastener



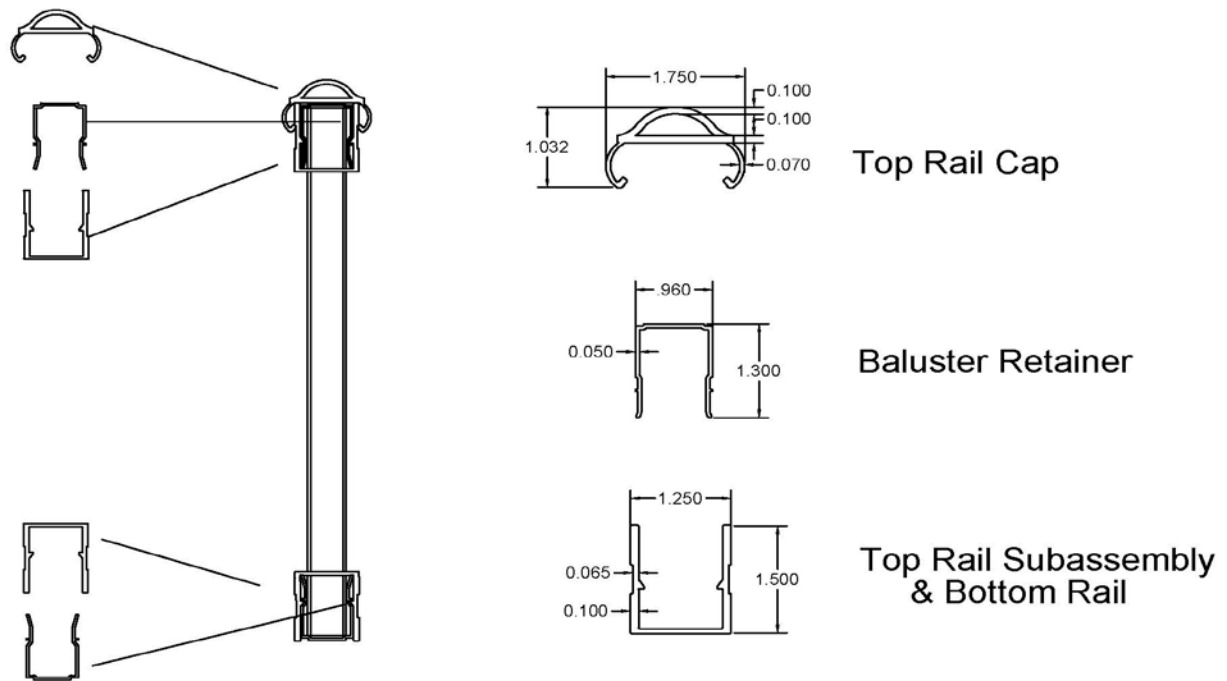
**Figure 1**  
**Keystone, American, and Arabian Aluminum Railing Systems**



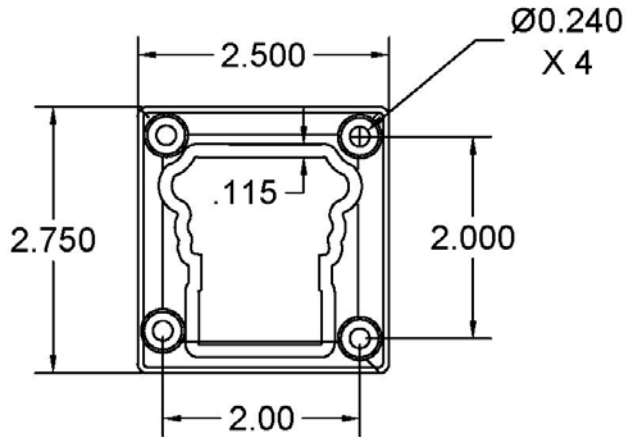
**Figure 2**  
**Keystone Aluminum Railing System**



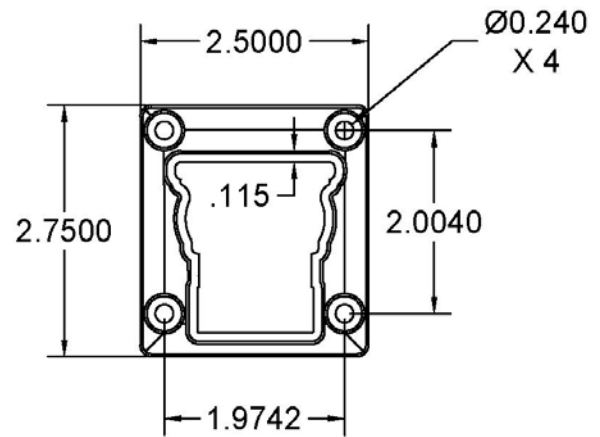
**Figure 3**  
**American Aluminum Railing System**



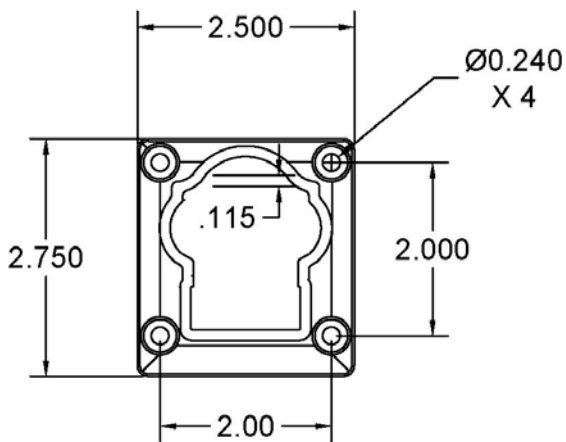
**Figure 4**  
**Arabian Aluminum Railing System**



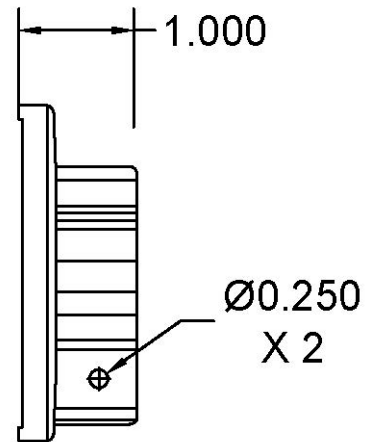
**Figure 5**  
**Keystone Top Rail Bracket**



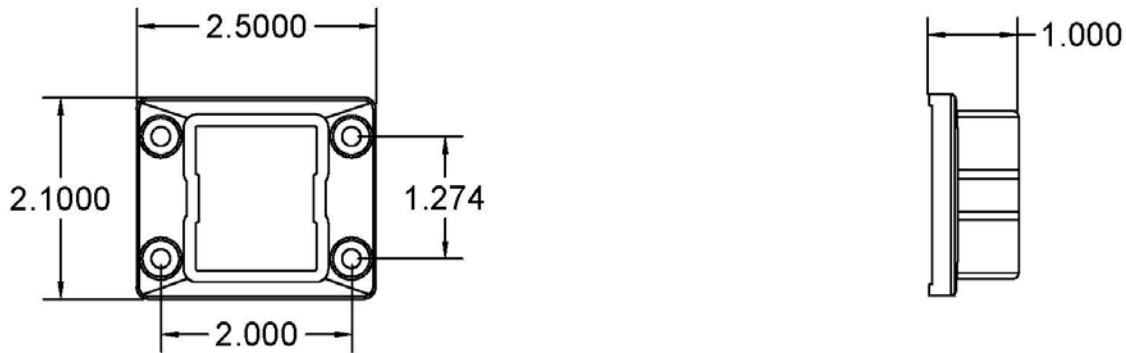
**Figure 6**  
**American Top Rail Bracket**



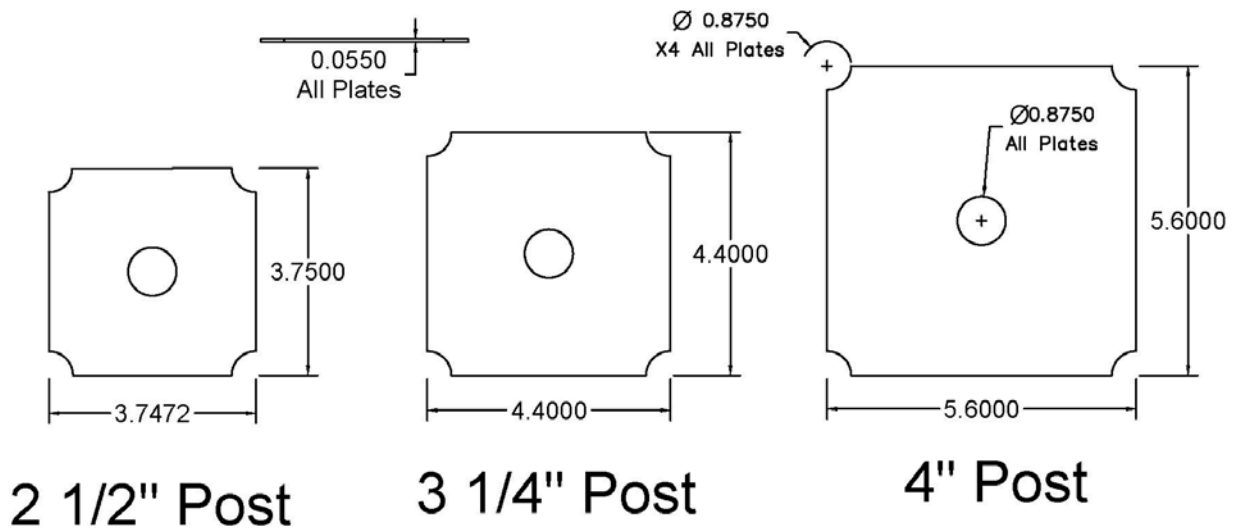
**Figure 7**  
**Arabian Top Rail Bracket**



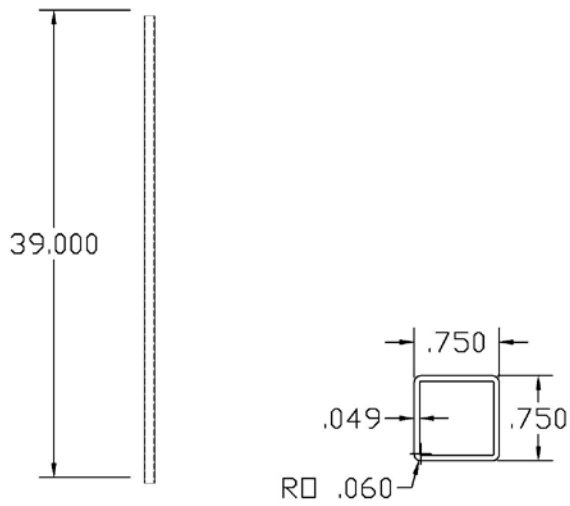
**Figure 8**  
**Keystone, American, and Arabian Top Rail Brackets Side View**



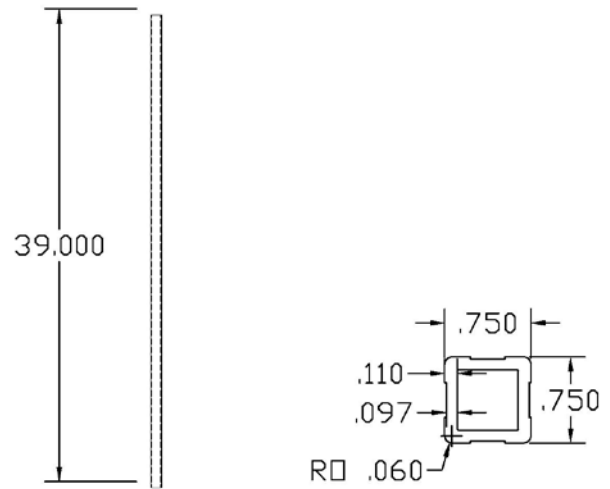
**Figure 9**  
*Keystone, American, and Arabian Bottom Rail Brackets*



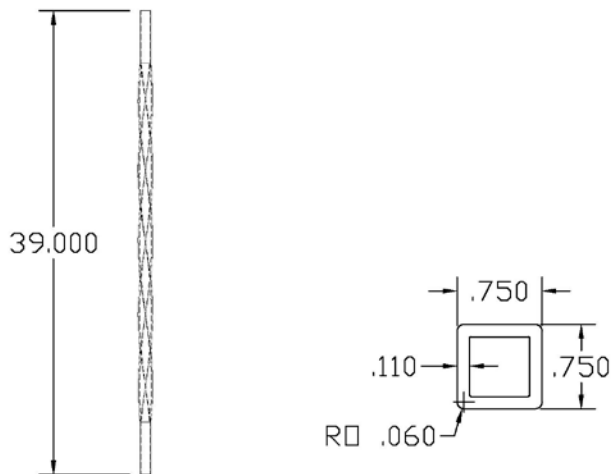
**Figure 10**  
*Stainless Steel Shim Plates*



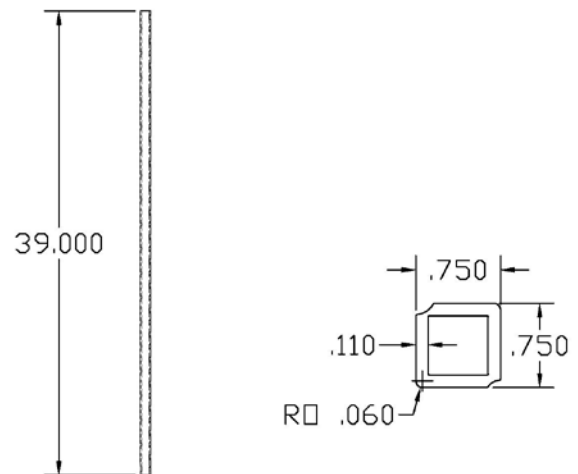
**Figure 11**  
**Square Baluster**



**Figure 12**  
**Indent Baluster**

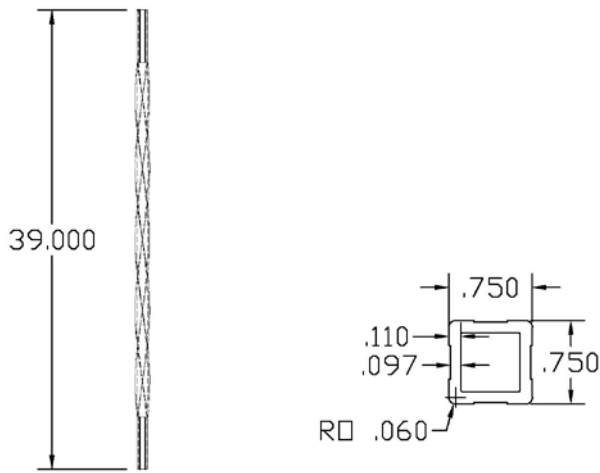


**Figure 13**  
**Twisted Baluster**

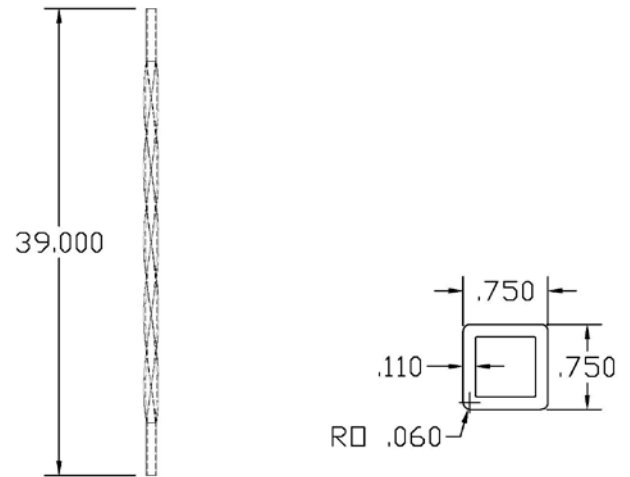


**Figure 14**  
**Hammered Baluster**

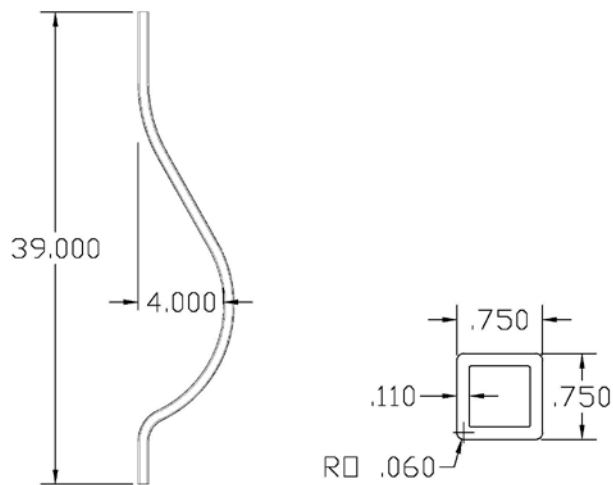




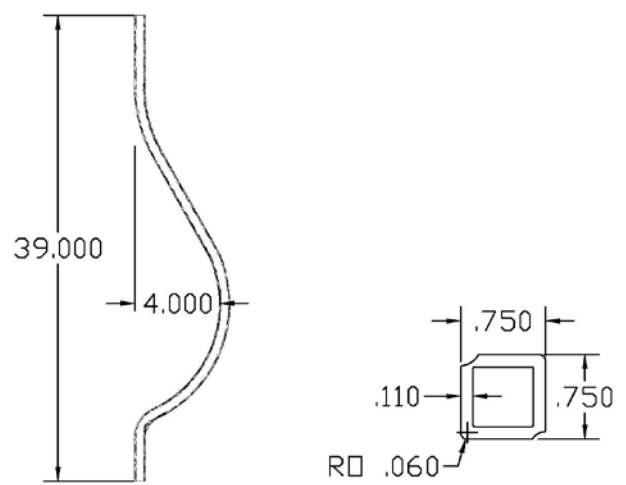
**Figure 15**  
**Twisted and Indented Baluster**



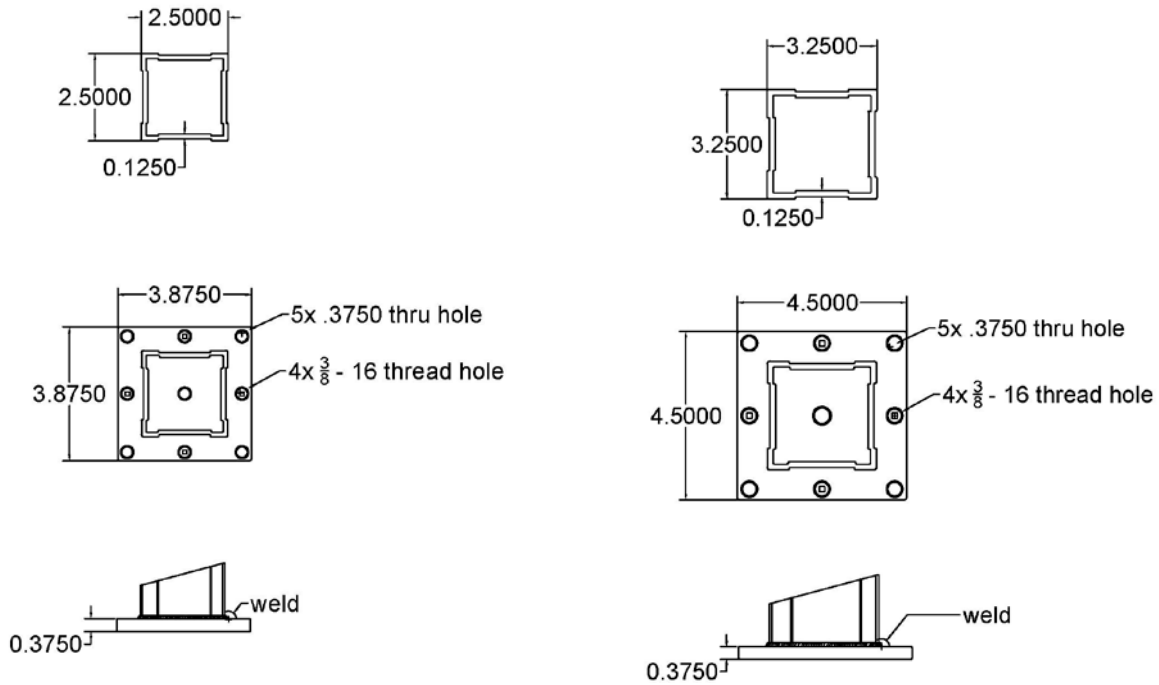
**Figure 16**  
**Hammered and Twisted Baluster**



**Figure 17**  
**4 in. Belly Baluster**

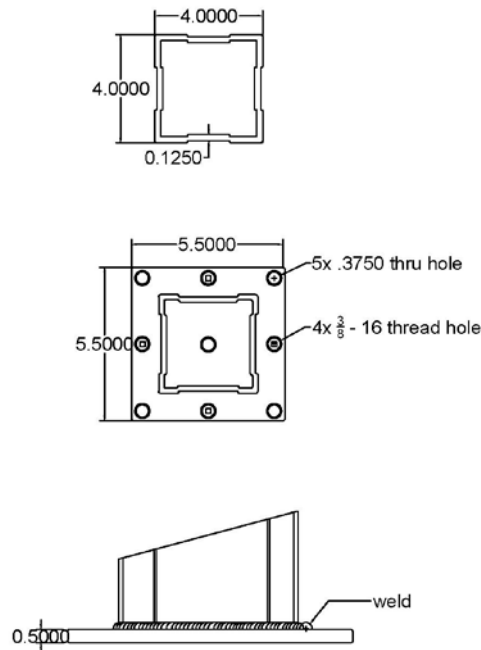


**Figure 18**  
**4 in. Hammered Belly Baluster**



**Figure 19**  
2.5 in. Welded Post

**Figure 20**  
3.25 in. Welded Post



**Figure 21**  
4 in. Welded Post