

8.5' Line Post Specifications

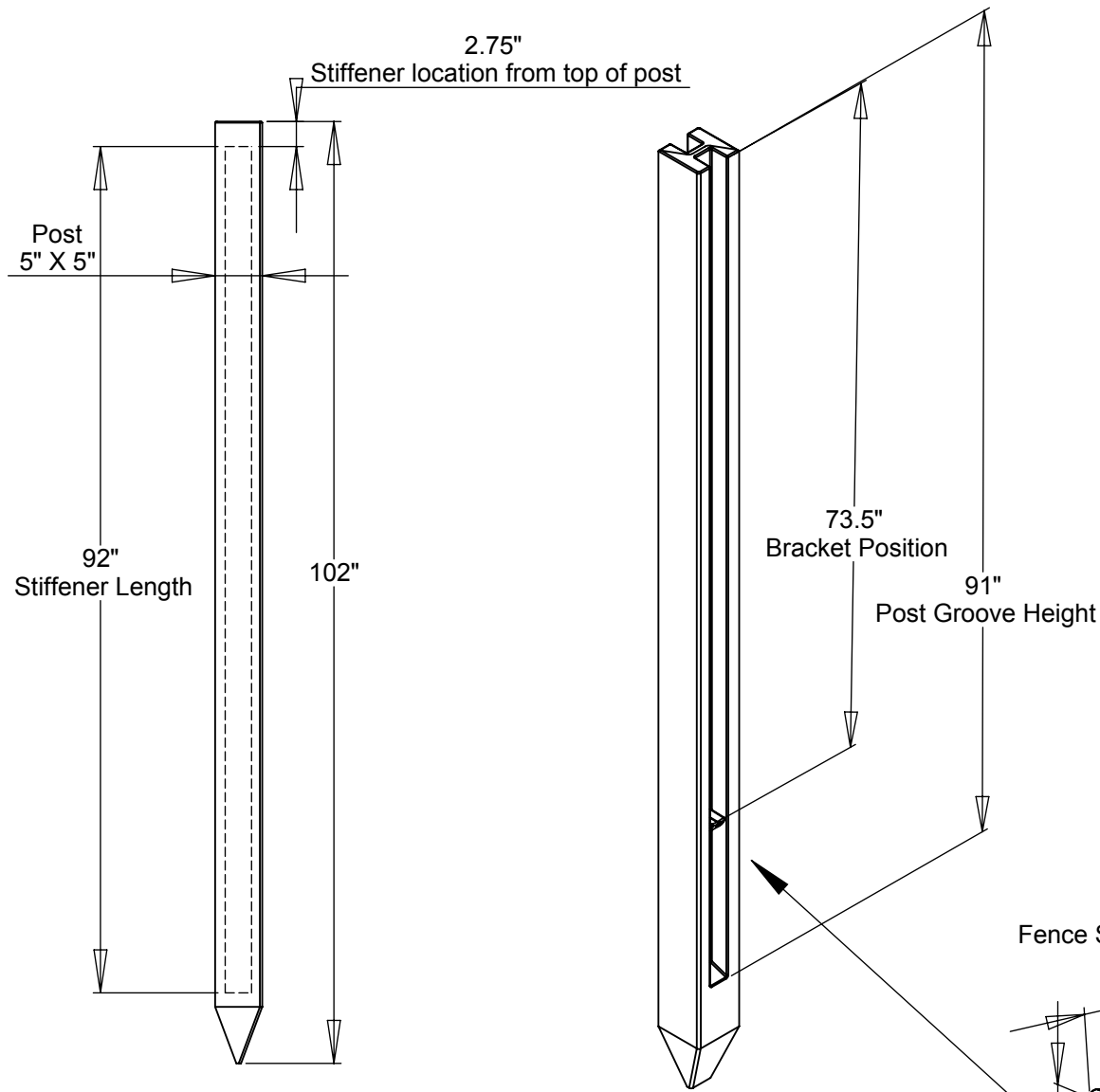

Line post cutaway

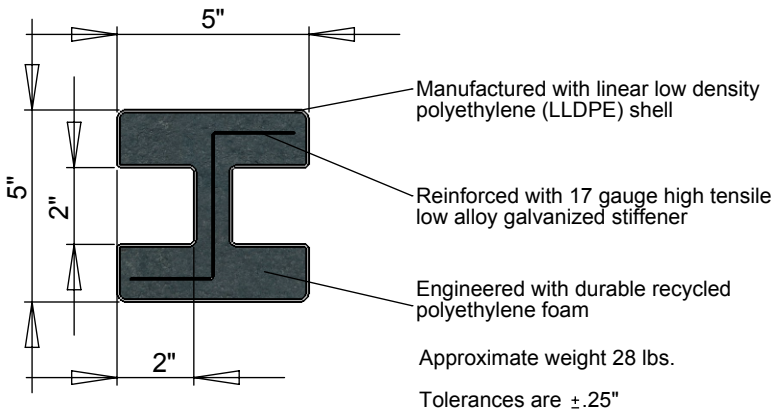

Fence Support Bracket

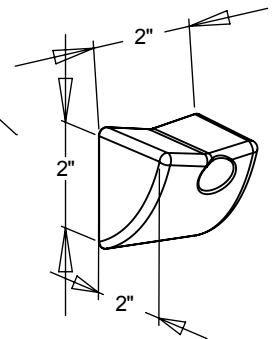

- Made with polypropylene copolymer plastic
- Triangulated shape for improved load distribution
- Zinc plated 1.5" self tapping screw and one bracket included per groove

Model #:LP102 E	This drawing may not be altered or reproduced without the permission of SimTek [™] Fence		 EcoStone www.ecostonefence.com
Date: January 3, 2011	Scale: not to scale	REV: GF	
Sheet 1 of 1	U.S. Patents: 7,478,797 / 7,635,114 Foreign Patents Pending		