

MULTI PADLOCK COMMERCIAL GATE LATCH
INSTALLATION INSTRUCTIONS

www.nationwideindustries.com

NOTE: PADLOCKS NOT INCLUDED.

1. Attach the latch arm to the bracket using the 4.5" long bolt with a nut using the bottom holes of the arm (Figure 1). The arm should be able to rotate upward at this point.
2. Align the latch to the gate frame at desired height, with the latch arm toward the fence post, and hold it in place while marking the location of the hole for the 2.75" long bolt (Figure 2). Remove the latch and drill a clearance hole through the gate frame at the marked location using a 25/64" drill bit.
3. Mount the latch to the gate frame using the u-bolt with two nuts, and the 2.75" long bolt with one nut (Figure 3).
4. With the arm in the down position, place all the lock tabs onto the side of the latch that will be used for locking, either Side A or Side B as shown in Fig. 3, and place a separate padlock (not included) on each tab to lock it (Figure 4). All lock tabs must be on the same side of the latch to lock the latch. To open the latch, unlock any individual tab and remove it from the latch. To relock the latch, place the tab back onto the side of the latch with the other tabs and place the padlock onto the tab.
5. As a lockout option, the latch may be locked with a single padlock by placing the padlock through the top hole of the latch arm (Figure 5). This will prevent the latch from opening even if a lock tab is removed.

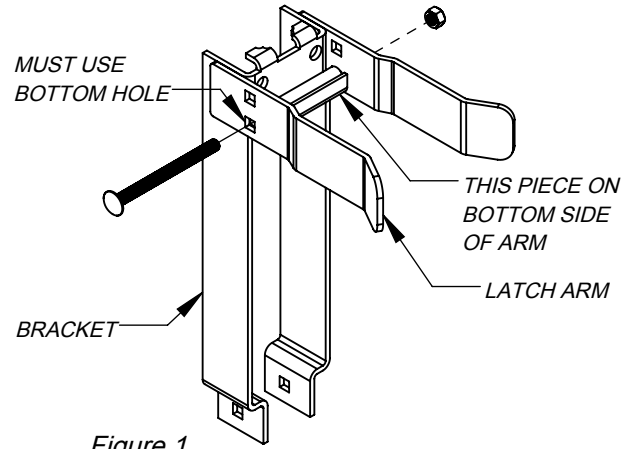

Figure 1

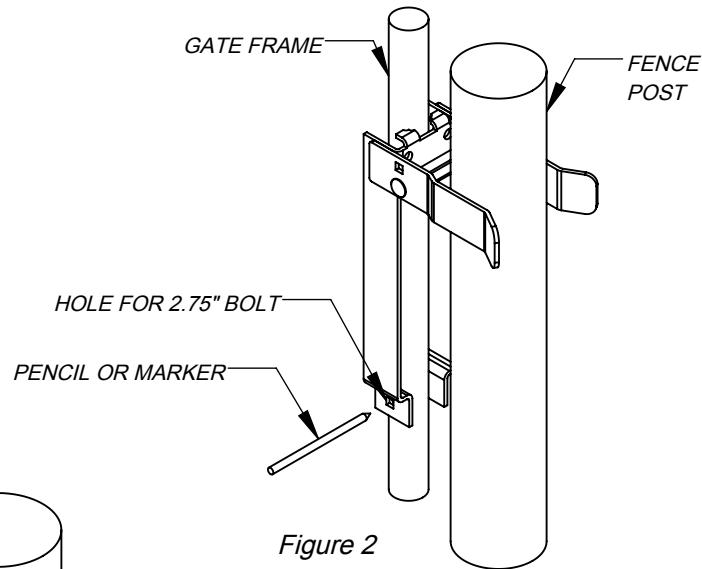

Figure 2

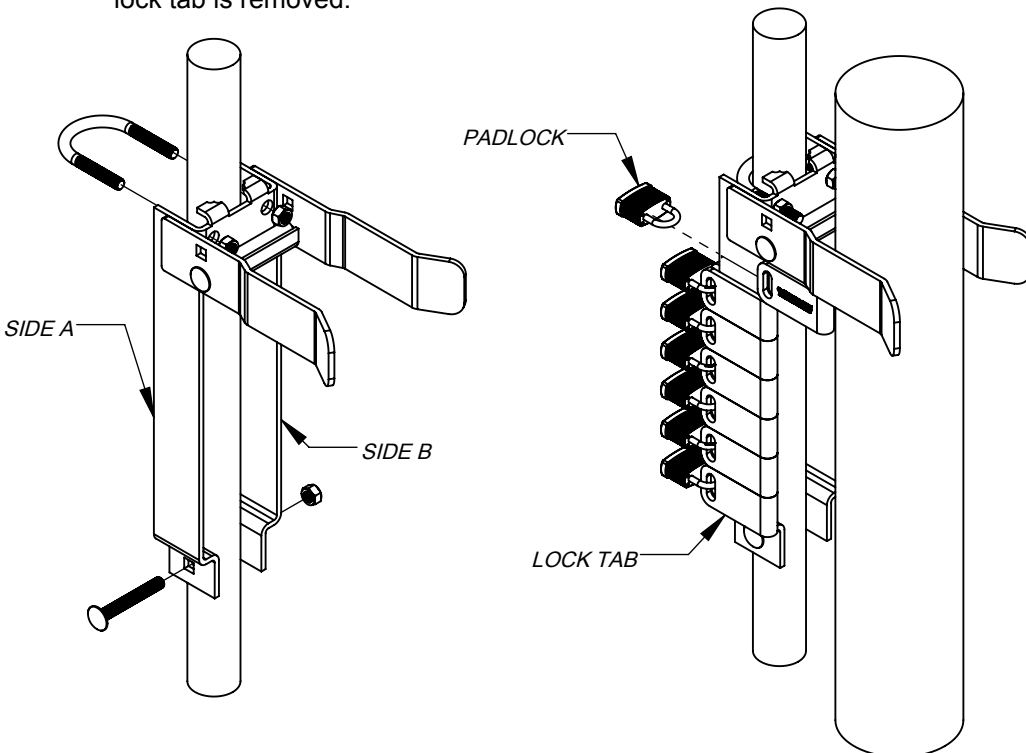

Figure 3

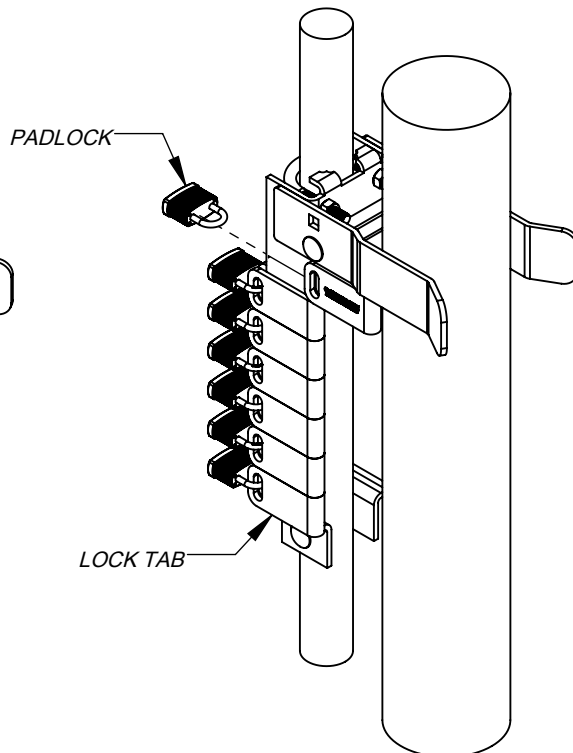

Figure 4

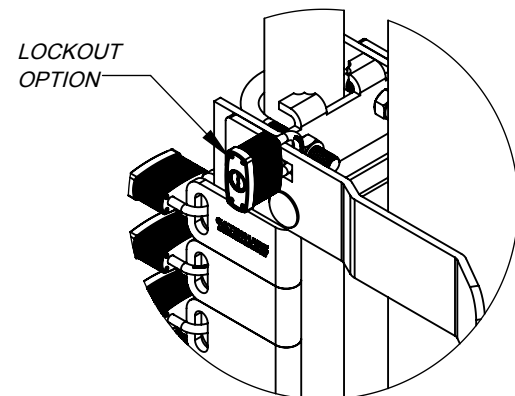
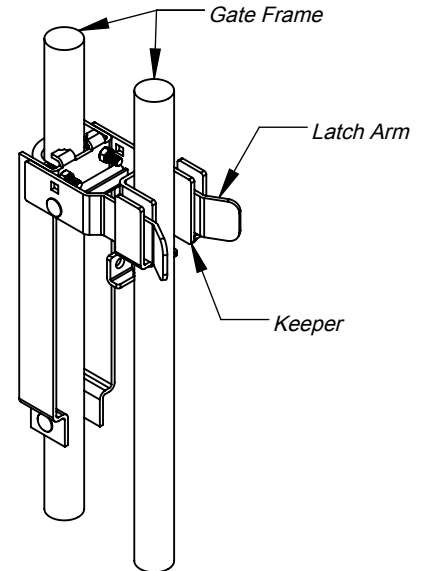
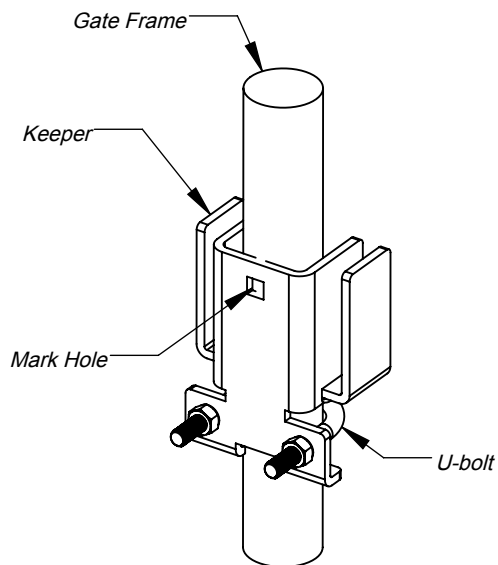
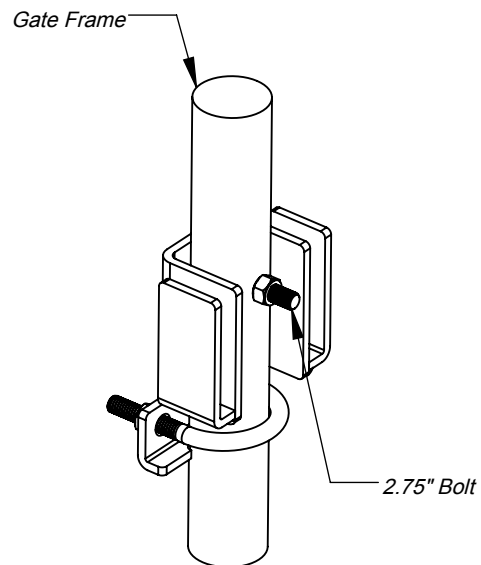

Figure 5

MULTI PADLOCK COMMERCIAL GATE LATCH**INSTALLATION, ADJUSTMENT AND MAINTENANCE INSTRUCTIONS*****INSTRUCTIONS FOR INSTALLING THE DOUBLE-DRIVE KEEPER
FOR DOUBLE DRIVE (DD) LATCH SETS, INSTALL LATCH FIRST - SEE OTHER SIDE***

6. With the latch installed (see other side), the gates in the closed position and the latch in the latched position, hold the keeper in position making sure the latch arms are completely engaged by the keeper (Figure 6). Mark the position of the keeper.
7. Open the gate and temporarily install the keeper using the supplied U-bolt, close gate and check for latch function. Align keeper as needed. Mark the location of the keeper thru bolt on the gate frame. (Figure 7)
8. Remove the keeper and drill a clearance hole through the gate frame at the marked location using a 25/64" drill bit.
9. Mount the keeper to the gate frame using the U-bolt and 2.75" long bolt (Figure 8).

*Figure 6**Figure 7**Figure 8*