

Post w/Welded Plate Installation Instructions



Note: Because codes vary from one region to another, you must consult your local building codes to determine acceptable post placement and railing height.

Components (for wood):

- (1) Post w/welded plate
- (1) Leveling plate
- (4) 3/8" x 1/2" set screws
- (4) 4" wood screws
- (1) T-30 Torx bit

Components (for concrete):

- (1) Post w/welded plate
- (1) Leveling plate
- (4) 3/8" x 1/2" set screws
- (4) 3 1/2" concrete screws
- (1) T-40 Torx bit

Site Preparation

Site preparation for the posts should include insuring that the layout is square. Begin by creating a rectangle with the sides parallel to each other.

Square can be determined by measuring from one corner of the layout to the other. These measurements should be the same.

A = A in diagram. If they are not, adjust the layout until they are.

Place the posts in line with each other.

Posts should rest on concrete that is 4" thick or more. Surface needs to be flat and the layout square. Concrete should be at least 4000 psi.

For posts mounted on wood, adequate support underneath the post is required.

Use a chalk line to position the brackets before marking the location of the posts prior to pre-drilling the holes.

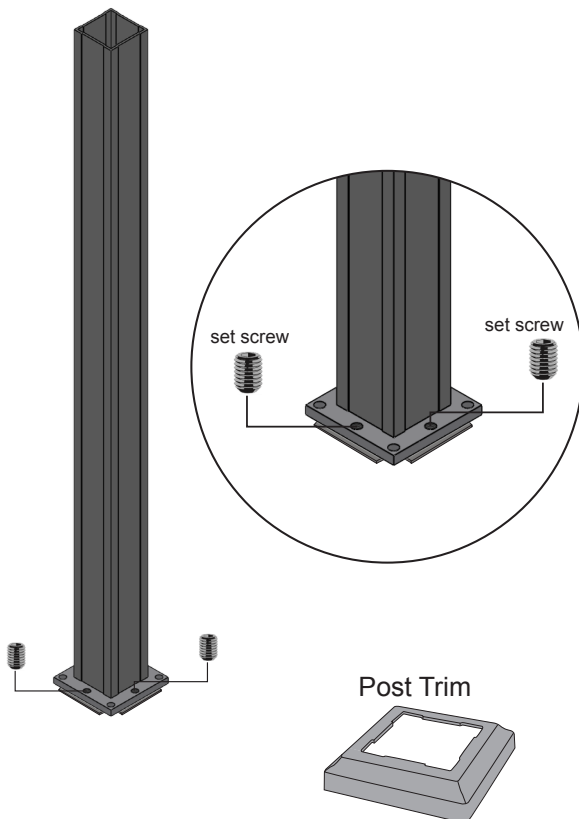
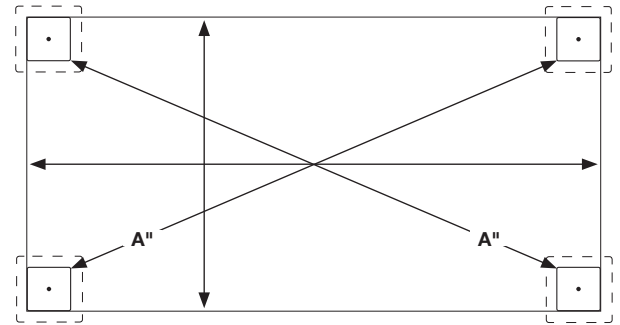

Post w/Welded Plate Installation

With your installation layout determined and post positions marked, place posts and mark screw locations (one in each corner of post).

Remove the post and using a 1/4" masonry bit (for concrete) or a 1/4" wood bit (for wood) drill a hole that is deeper than the length of the bolt.

Position the posts on top of the leveling plates and in line with your predrilled holes then, using the Starhead Torx drive bit (provided), partly tighten the 3 1/2" concrete screws (or 4" wood screws depending on the job) until snug.

Thread the four leveling set screws into the post base and, using a level, adjust the leveling set screws with a 3/16" allen wrench until the post is plumb.

Fully tighten the wood or concrete screws.

NOTE!
Post Trim
recommended at
bottom of post