

GSLG-A

INSTALLATION GUIDE

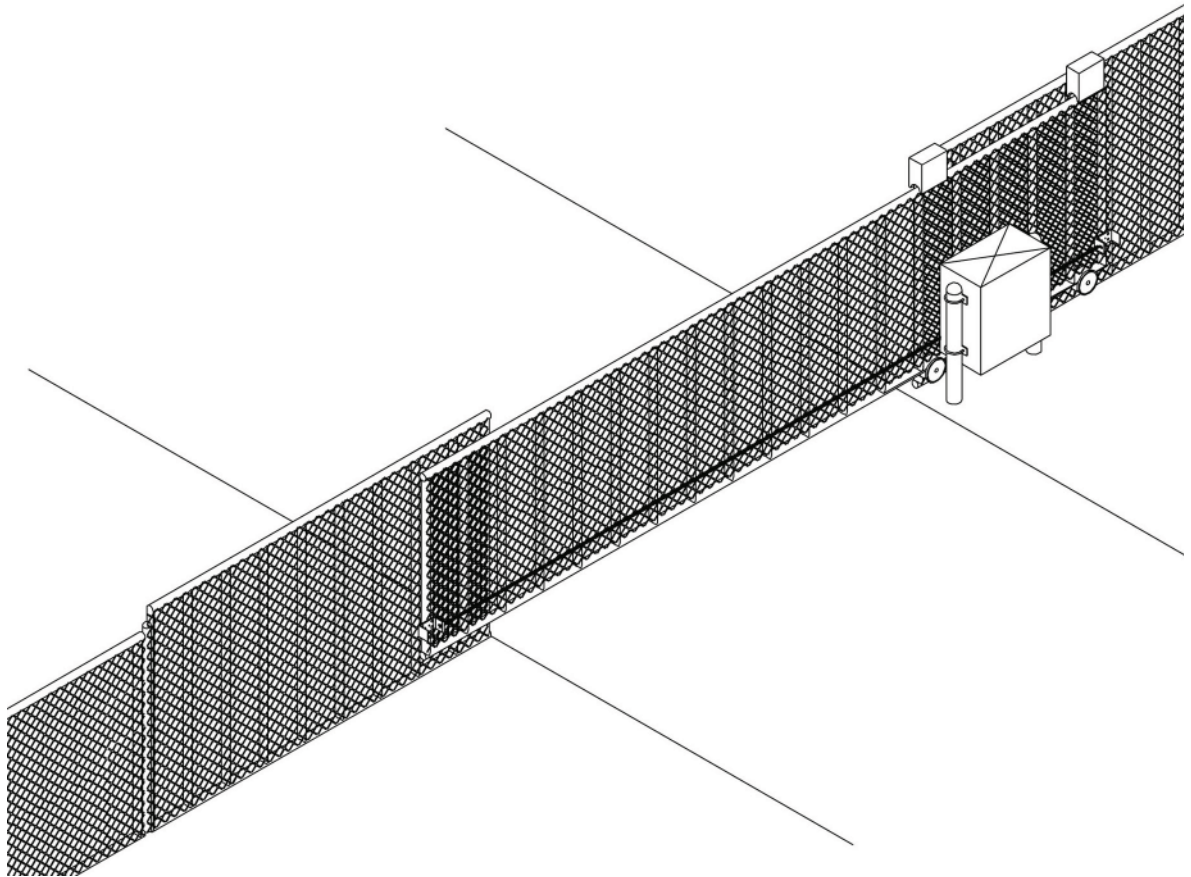

Linear[®]
Building On Innovation.

USA & Canada (800) 421-1587 & (800) 392-0123
(760) 438-7000 - Toll Free FAX (800) 468-1340
www.linearcorp.com



**UL325 COMPLIANCE REQUIRES THE USE OF CONTACT EDGES
OR PHOTOELECTRIC CONTROLS ON ALL AUTOMATIC OR
REMOTELY-CONTROLLED GATE OPERATORS.**

GSLG-A OPERATOR INSTALLATION GUIDE

TABLE OF CONTENTS

PRE-INSTALLATION INFORMATION

| | |
|---------------------------------------|---|
| Gate Operator Classifications | 3 |
| Safety Information and Warnings | 3 |
| Pre-Installation Information | 3 |

INSTALLATION

| | |
|---------------------------------------------------|---|
| Wiring Specifications..... | 4 |
| Post Mounting Instructions..... | 5 |
| Gate Bracket and Chain Assembly Instructions..... | 6 |
| Vent Plug Installation..... | 7 |
| Torque Limiter Adjustments..... | 7 |
| Electrical Connection and Adjustments..... | 8 |
| Limit Nut Adjustments | 8 |

CONTROL BOARD ADJUSTMENTS and ACCESSORY CONNECTIONS

| | |
|--------------------------------------------------------------------|-------|
| Control Board Adjustments | 9 |
| Terminal Connection Descriptions..... | 10 |
| Current Sensing Adjustments | 11 |
| Close Direction Current Sense Adjustment..... | 11 |
| Open Direction Current Sense Adjustment..... | 11 |
| Maximum Run Timer Adjustment..... | 11 |
| Auto Close Timer Adjustment..... | 11 |
| Master/Slave Connection | 11 |
| Onboard L.E.D. Indicator Descriptions..... | 12 |
| Important Notes for Installation of Master/Slave Applications..... | 13 |
| Surge Protector Instructions..... | 13 |
| Control and Accessory Connection Illustrations..... | 14-17 |

ILLUSTRATIONS

| | |
|-----------------------------------|----|
| Loop Layout Illustration | 18 |
| Edge Layout Illustration #1 | 19 |
| Edge Layout Illustration #2..... | 20 |
| Photo Eye Illustration | 21 |
| Picket Gate Illustration | 22 |
| Track Gate Illustration..... | 23 |

TROUBLESHOOTING

PARTS LISTS

| | |
|--------------------------------------------------------------------------|----|
| How to Order Replacement Parts | 24 |
| Model GSLG-A Mechanical Parts Exploded View..... | 25 |
| Model GSLG-A Mechanical Parts List..... | 26 |
| Model GSLG-A Single Phase Control Box Exploded View and Parts List | 27 |
| Model GSLG-A Three Phase Control Box Exploded View and Parts List | 28 |

PREVENTATIVE MAINTENANCE

| | |
|--------------------------------------------|----|
| GATE OPERATOR INSTALLATION CHECKLIST | 32 |
|--------------------------------------------|----|

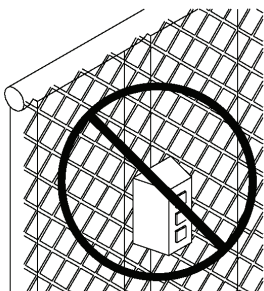

CAUTION!
DO NOT INSTALL
CONTROLS ON A
GATE OR FENCE
LINE

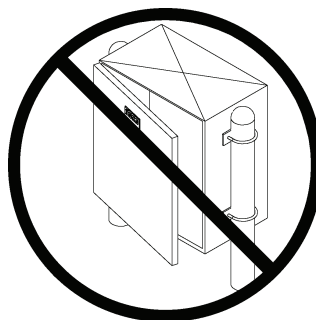

CAUTION!
ONLY QUALIFIED SERVICE
TECHNICIANS SHOULD
WORK ON A LINEAR
SLIDE GATE OPERATOR

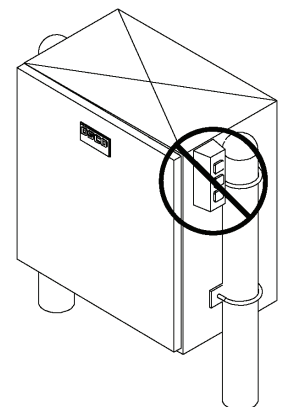

DO NOT INSTALL
CONTROLS
ON THE OPERATOR

GSLG-A OPERATOR INSTALLATION GUIDE

GATE OPERATOR CLASSIFICATIONS

All gate operators can be divided into one of four different classifications, depending on their design and usage.

Class I: Residential

A vehicle gate operator (or system) intended for use in a home of one to four single-family dwellings, or a garage or parking area associated therewith.

Class II: Commercial or General Public Access

A vehicular gate operator (or system) intended for use in a commercial location or building such as a multi-family housing unit (five or more single-family units), hotel, garage, retail store, or other building servicing the general public.

Class III: Industrial or Limited Access

A vehicular gate operator (or system) intended for use in an industrial location or building such as a factory or loading dock area or other locations not intended to service the general public.

Class IV: Restricted Access

A vehicular gate operator (or system) intended for use in a guarded industrial location or building such as an airport security area or other restricted access locations not servicing the general public, in which unauthorized access is prevented via supervision by security personnel.

IMPORTANT!!

Before installing the gate operator, make sure the gate's slide is free and level throughout the entire opening distance. If the gate does not seem to operate properly, it may affect the operator performance or greatly shorten the life of the unit. The gate should be designed so that airflow through the fabric is ample to prevent wind resistance and drag.



SAFETY INFORMATION AND WARNINGS

Read the following before beginning to install LINEAR slide gate operators:

1. Read the yellow "Safety Instructions" brochure enclosed with the packet of information. If you do not have one, please call LINEAR at 1-800-333-1717 to request one. Read and follow all instructions.
2. All electrical connections to the power supply must be made by a licensed electrician and must observe all national and local electrical codes.
3. A separate power-disconnect switch should be located near the operator so that primary power can be turned off when necessary.
4. A minimum of two (2) WARNING SIGNS shall be installed, one on each side of the gate where easily visible.
5. Never reach between, through or around the fence to operate the gate.
6. You must install all required safety equipment.

PRE-INSTALLATION INFORMATION

Before unpacking, inspect the carton for exterior damage. If you find damage, advise the delivery carrier of a potential claim.

Inspect your package carefully. You can check your accessory box parts with the enclosed packing slip for your convenience. Claims for shortages will be honored for only 30 days from the date of shipment.

Before installing the operator, read this manual completely to ensure all requirements for proper installation are present. Verify that the voltage to be used matches the voltage of the operator.

The following contact or non-contact obstruction detection devices have been approved for use with LINEAR slide gate operators as part of a UL325 compliant installation:

Contact Edges:

Miller Models*: MG0-20, MGR-20, MGS-20, and ME-120

Photoeyes:

2520-441 MMTTC Model IR-55 photoeye, 165' with mounting hardware
2520-031 MMTTC Model E3K photoeye, 28' with mounting hardware

**for LINEAR part numbers, contact a sales representative for details*

GSLG-A OPERATOR INSTALLATION GUIDE

WIRING SPECIFICATIONS

- Select from the chart at the bottom of this page corresponding to the model, voltage and horsepower rating of your operator.
- The distance shown on the chart is measured in feet from the operator to the power source. **DO NOT EXCEED THE MAXIMUM DISTANCE.** These calculations have been based on standard 115V and 230V supplies with a 10% drop allowable. If your supply is under the standard rating, the runs listed may be longer than what your application will handle, and you should not run wire too near the upper end of the chart for the gauge of wire you are using.
- When large-gauge wire is used, a separate junction box (not supplied) may be needed for the operator power connection.
- All control devices are now 24VDC, which can be run considerable distances. 24VAC is available for other devices, such as loop detectors and photo eyes.
- Wire run calculations are based on the National Electrical Code, Article 430 and have been carefully determined based on motor inrush, brake solenoids, and operator requirements.
- Connect power in accordance with local codes. **The green ground wire must be properly connected.**
- Wire insulation must be suitable to the application.
- Control wiring must be run in a separate conduit from power wiring. Running them together may cause interference and faulty signals in some accessories.
- Electrical outlets are supplied in all 115VAC models for convenience with occasional use or low power consumption devices only. If you choose to run dedicated equipment from these devices, it will decrease the distance for maximum run and the charts will no longer be accurate.
- A three-wire shielded conductor cable is required to connect master and slave operators. You must use Belden 8760 Twisted Pair Shielded Cable (or equivalent) **only** – LINEAR part number 2500-1982, per foot). See page 9 for details of this connection, as well as dip switch selection. **Note: The SHIELD wire should be connected in both the master and slave operators**

USE COPPER WIRE ONLY!

MODEL GSLG-A – SINGLE PHASE

| Power Wiring | | | | | | | | | | | |
|--------------|--------------|------|------------|------------|--------------|------|------------|------------|--------------|------|------------|
| Volts & HP | Max Distance | | Wire Gauge | Volts & HP | Max Distance | | Wire Gauge | Volts & HP | Max Distance | | Wire Gauge |
| | Single | Dual | | | Single | Dual | | | Single | Dual | |
| 115V | 222 | 111 | 12 | 208V | 760 | 380 | 12 | 230V | 894 | 447 | 12 |
| | 354 | 177 | 10 | | 1200 | 600 | 10 | | 1422 | 711 | 10 |
| | 566 | 283 | 8 | | 1924 | 962 | 8 | | 2264 | 1132 | 8 |
| 1/2 HP | 900 | 450 | 6 | 1/2 HP | 3060 | 1830 | 6 | 1/2 HP | 3600 | 1800 | 6 |
| | 1430 | 715 | 4 | | 4864 | 2432 | 4 | | 5724 | 2862 | 4 |
| 115V | 178 | 89 | 12 | 208 | 604 | 302 | 12 | 230V | 710 | 355 | 12 |
| | 282 | 141 | 10 | | 958 | 478 | 10 | | 1128 | 564 | 10 |
| | 450 | 225 | 8 | | 1526 | 763 | 8 | | 1796 | 898 | 8 |
| 3/4 HP | 716 | 358 | 6 | 3/4 HP | 2424 | 1212 | 6 | 3/4 HP | 2852 | 1426 | 6 |
| | 1140 | 570 | 4 | | 3856 | 1928 | 4 | | 4538 | 2269 | 4 |
| 115V | 160 | 80 | 12 | 208V | 544 | 272 | 12 | 230V | 640 | 320 | 12 |
| | 254 | 127 | 10 | | 864 | 432 | 10 | | 1016 | 508 | 10 |
| | 406 | 203 | 8 | | 1374 | 686 | 8 | | 1616 | 808 | 8 |
| | 646 | 323 | 6 | | 2184 | 1092 | 6 | | 2570 | 1285 | 6 |
| | 1026 | 513 | 4 | | 3476 | 1738 | 4 | | 4090 | 2045 | 4 |
| 1HP | | | | 1HP | | | | 1HP | | | |

ACCESSORY WIRING

| All Models | | |
|-----------------------------|------------------------|------------|
| Volts | Maximum Distance (ft.) | Wire Gauge |
| 24VAC | 250 | 14 |
| | 350* | 12 |
| 24VDC | 0-2000 | 14 |
| *Over 350 ft. use DC power. | | |

MODEL GSLG-A – THREE PHASE

| Power Wiring: 3 Phase | | | | | | | | | | | |
|-----------------------|--------------|------|------------|----------------|--------------|------|------------|----------------|--------------|------|------------|
| Volts & HP | Max Distance | | Wire Gauge | Volts & HP | Max Distance | | Wire Gauge | Volts & HP | Max Distance | | Wire Gauge |
| | Single | Dual | | | Single | Dual | | | Single | Dual | |
| 208V 1/2 HP | 1142 | 571 | 12 | 230V 1/2 HP | 1344 | 672 | 12 | 460V 1/2 HP | 3841 | 1921 | 12 |
| | 1816 | 908 | 10 | | 2137 | 1069 | 10 | | 6106 | 3053 | 10 |
| | 2890 | 1445 | 8 | | 3400 | 1700 | 8 | | 9712 | 4856 | 8 |
| 208V 3/4 HP | 920 | 460 | 12 | 230V 3/4 HP | 1084 | 542 | 12 | 460V 3/4 HP | 3279 | 1640 | 12 |
| | 1464 | 732 | 10 | | 1723 | 862 | 10 | | 5212 | 2606 | 10 |
| | 2330 | 1165 | 8 | | 2741 | 1371 | 8 | | 8291 | 4146 | 8 |
| 208V 1HP | 714 | 357 | 12 | 230V 1HP | 840 | 420 | 12 | 460V 1HP | 2689 | 1345 | 12 |
| | 1136 | 568 | 10 | | 1336 | 668 | 10 | | 4274 | 2437 | 10 |
| | 1804 | 902 | 8 | | 2124 | 1062 | 8 | | 6798 | 3399 | 8 |

GSLG-A OPERATOR INSTALLATION GUIDE

POST MOUNTING INSTRUCTIONS FOR MODEL **GSLG-A**

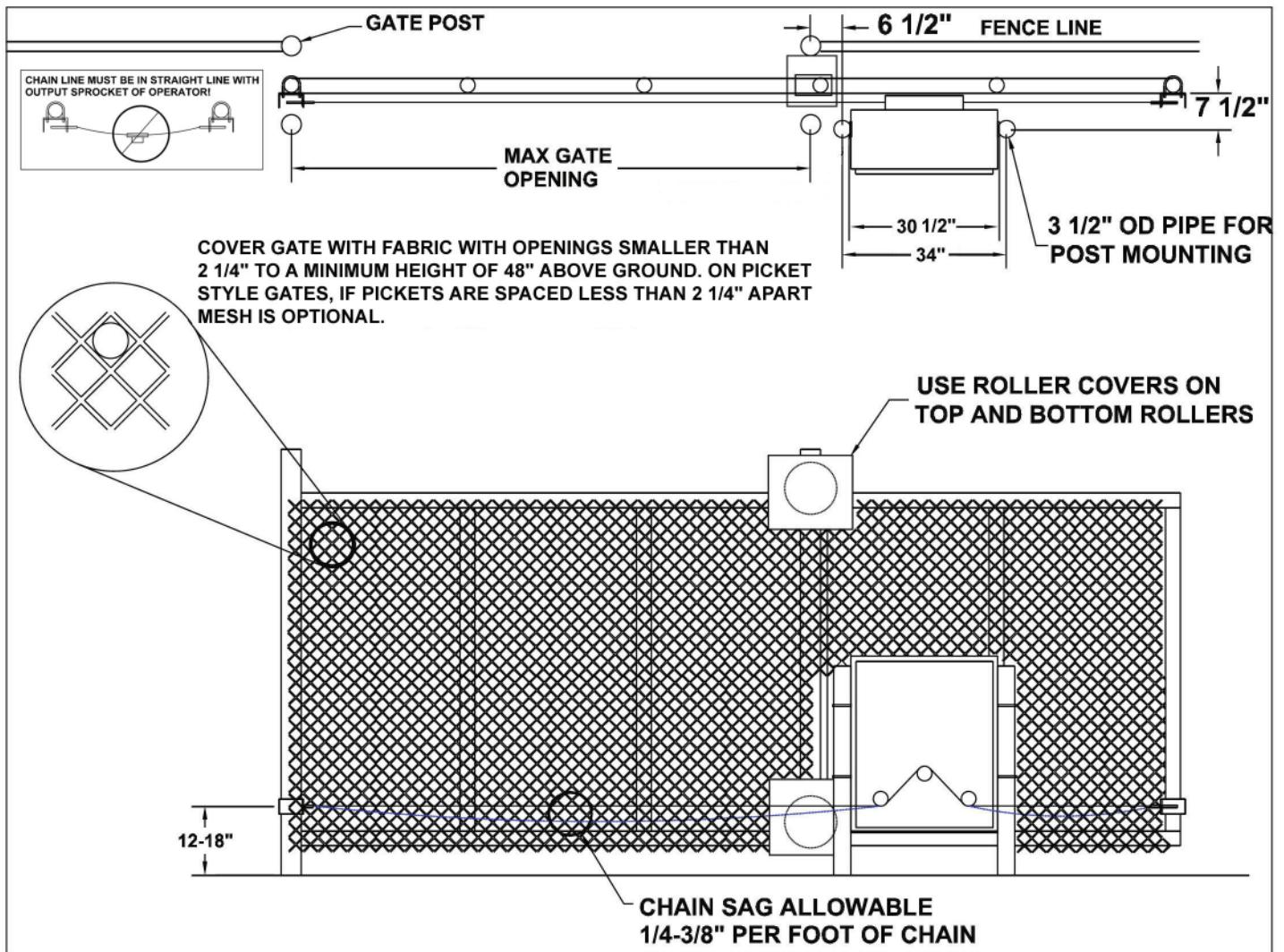

Before installing, make sure the gate rolls or slides freely, and that all exposed rollers are properly covered. The gate must be covered with fabric with openings no larger than 2 1/4" in size, to a minimum height of 48 inches from ground level. On picket-style gates, if pickets are spaced less than 2 1/4" apart, mesh is optional.

Use two 3 - 3 1/2" OD galvanized posts and secure with concrete footings as shown, length to be determined by local codes, frost line depth and soil conditions. Secure the operator to the posts using the 4" U-bolts, side plates, and hardware. There are a total of eight side plates. There are six 3/16" side plates which should be mounted on the outside top and bottom of the cabinet, two 3/16" side plates which go on the top inside and two 1/2" side plates which should be mounted on the inside top of the cabinet as shown in the illustration at the right.

To assemble the drive chain and gate brackets, refer to page 6. Make sure that the chain sag does not exceed recommended sizes and that the chain does not come into contact with the moving parts of the gate or ground.

For optional pad mounting instructions, see LINEAR drawing #2700-360.

The operator is intended for installation only on gates used for vehicles. Pedestrians must be supplied with a separate access opening. The pedestrian access opening shall be designed to promote pedestrian usage. Locate the gate such that persons will not come in contact with the vehicular gate during the entire path of travel of the vehicular gate.

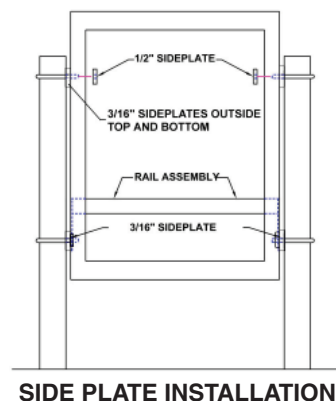

GSLG-A OPERATOR INSTALLATION GUIDE

GATE BRACKET AND CHAIN ASSEMBLY INSTRUCTIONS

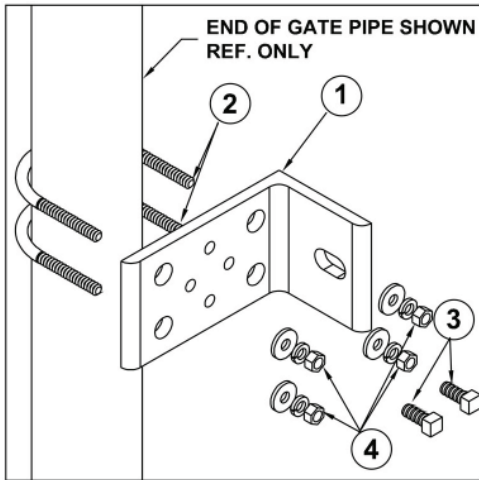

Numbered items in these drawings are for instructional reference only. For actual part numbers, go to the parts lists in the back of this booklet.

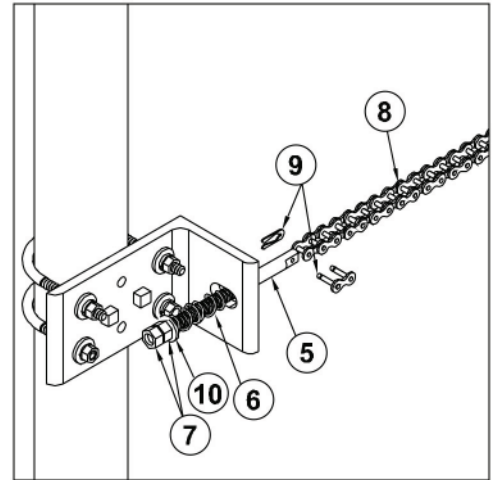

NOTE: IDLER CONFIGURATION MAY APPEAR DIFFERENT DEPENDING ON SLIDE OPERATOR MODEL

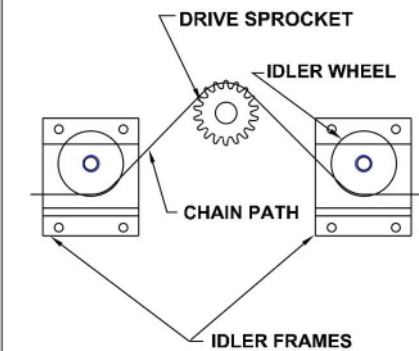

SOME MODELS MAY APPEAR MORE LIKE THIS:

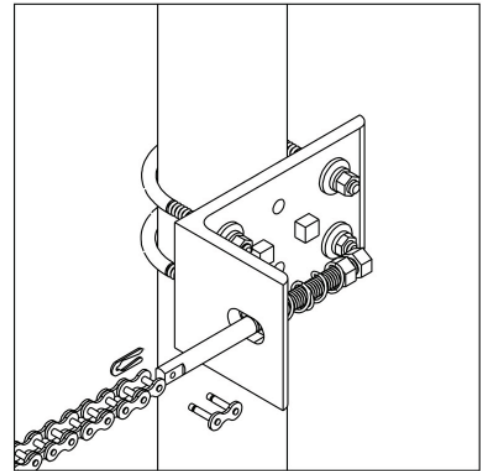
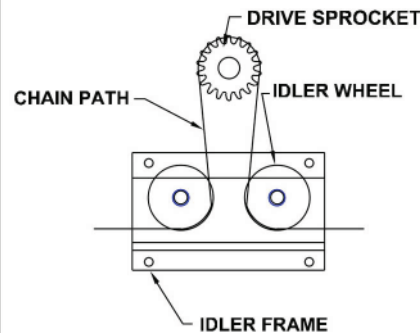

Assemble a gate bracket (1) to the front edge of the gate, using two U-bolts (2), and mounting hardware (3). Before tightening down completely, be sure the bracket is parallel to the gate. Tighten the U-bolt hardware the rest of the way, then screw the square head bolts (4) into the threaded holes in the gate plate until they bottom out against the gate. These will help keep the bracket from twisting on the pipe.

Slide a threaded chain pin (5) through the bracket as shown, with spring (6), flat washer (10), and two hex nuts (7). Attach one end of the drive chain (8) to the chain pin using master link (9) and begin unrolling it toward the operator.

Remove the rain cover from the back of the slide gate operator. Carefully thread the drive chain under the first idler, over the drive sprocket, and then under the last idler. Make sure you feed most of the chain through the sprockets for attaching to the back end of the gate.

Assemble the other gate bracket on the rear edge of the gate, using the same process as you did with the front gate bracket. Once this is done, take the other chain pin, spring and jam nuts and assemble with the end of drive chain and the other master link.

At this point you should be able to adjust the chain tension by tightening the jam nuts on each end. Approximately 1/4" to 3/8" of slack per foot of drive chain is acceptable. Make sure the chain does not drag on the ground, across the gate rollers or the idler frame of the operator.

Additional mounting holes have been provided in the gate bracket for installer convenience.

GSLG-A OPERATOR INSTALLATION GUIDE

VENT PLUG INSTALLATION

Gear reducers used in LINEAR gate operators will have solid plugs installed prior to shipment in order to keep the oil inside from spilling out during shipping. A vent plug has been provided to replace this plug during installation. This plug will look similar to the ones shown below. Some models may have a vent plug with a breather pin. This pin should be removed after installing the operator.

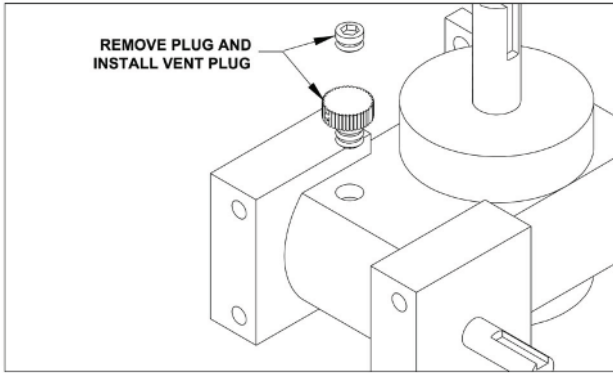

OR

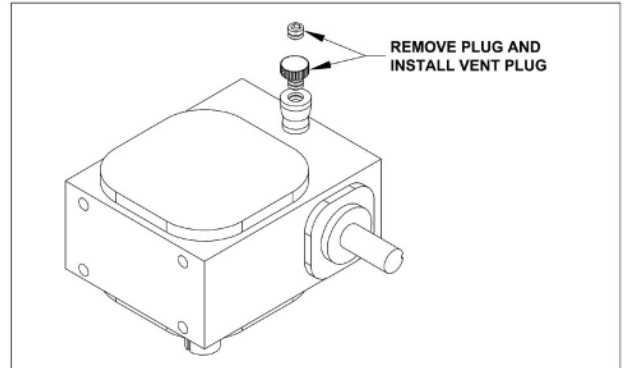

TORQUE LIMITER ADJUSTMENTS

Before adjusting the torque limiter, make sure the gate is in good working condition. One person should be able to move the gate by hand. Be certain the gate moves freely and without binding throughout its travel. Torque limiters are set light at the factory and must be adjusted during installation. Adjust the torque limiter tight enough to keep it from slipping during normal operation.

To adjust the torque limiter in model GSLG-A

1. Loosen the setscrew in the adjustment nut.
2. *To increase the output*, turn the adjustment nut clockwise one flat, or 1/6 turn, at a time until desired output is obtained.
To reduce the output, turn the adjustment nut counterclockwise one flat, or 1/6 turn, at a time until desired output is obtained.
3. Retighten the setscrew in the adjustment nut.

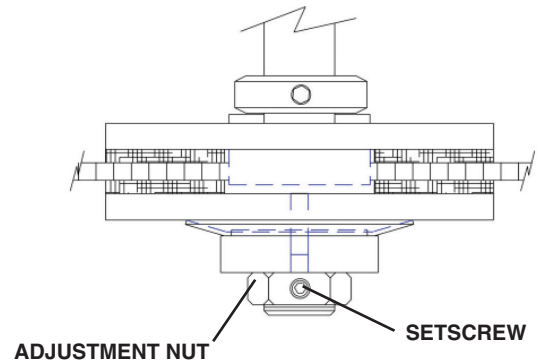

MODEL GSLG-A

GSLG-A OPERATOR INSTALLATION GUIDE

ELECTRICAL CONNECTION AND ADJUSTMENTS



Power supply must be of correct voltage and phase.
Always disconnect power from operator before servicing.
Keep clear of gate during operation.

All LINEAR gate operators are supplied with a power disconnect switch to turn on and off the power supply available to the operator. Incoming power should be brought into the operator and connected to the labeled pigtails in the disconnect box following wiring specifications on page 4. A wiring connections print can be found on the inside cover of the operator.

Proper thermal protection is supplied with the operator. The motor contains a thermal overload protector to protect from overheating the motor due to overload or high-frequency operation. This overload will automatically reset after the motor cools down.

LIMIT NUT ADJUSTMENTS

The limit nuts are not preset at the factory and must be adjusted for the length of the gate the operator is installed on. The limit switches are activated by two threaded nylon rotary limit nuts which are attached to a threaded shaft and driven by chain and sprockets from the main drive shaft. Remove the cardboard filler before attempting to adjust the limit nuts.

With the gate connected to the gate operator in a mid-travel position, and the power disconnect switch turned **OFF**, disconnect the operator by using the manual disconnect lever. Instructions for the manual disconnect can be found in the individual operator owner's guides. Once the operator has been disconnected, manually move the gate by hand to within a foot of its fully open position (the foot of distance is necessary to allow for coasting of the operator after the limit switch is tripped).

Once the gate is in this position, adjust the open limit nut until it activates the limit switch for open, **LSO-1**. Press down on the detent plate and rotate the nut along the threaded shaft. Refer to the illustration below for additional details.

Once the open limit nut is set, repeat the above process for the close direction nut and the **LSC-1** limit switch.

After finishing the initial limit nut adjustments, reposition the gate to approximately its center of travel. Re-engage the operator and turn the power disconnect **ON**. Stand clear of any moving parts and press the **OPEN** button on the three-button station. If the gate begins to close instead of open, press the **STOP** button immediately. Find the dip switch block on the main control board and switch the hand of operation (dip switch #4, see page 9) and try to open the gate again. Observe the gate as it runs through a complete cycle in both directions, and adjust your limits again if necessary. Fine levels of adjustment can also be achieved by adjusting a few teeth on the nut at a time. If the gate stops in mid travel, the open or close current sensor adjustment or the maximum run timer may need adjustment (see page 11).

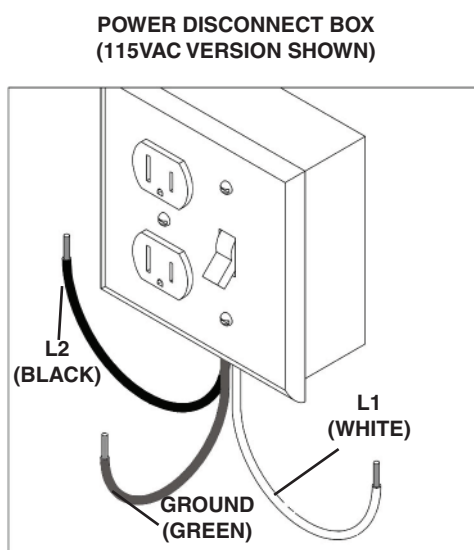

ROTARY LIMIT BOX ASS'Y
(SWITCHES AND BOX MAY
LOOK SLIGHTLY DIFFERENT
DEPENDING ON MODEL)

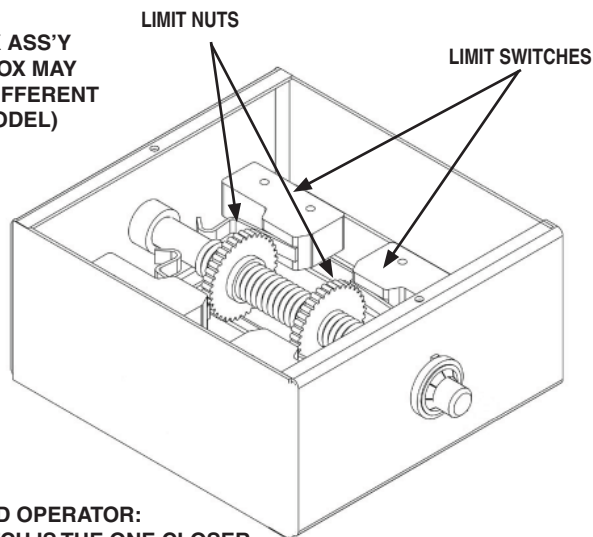

ON A RIGHT-HAND OPERATOR:
OPEN LIMIT SWITCH IS THE ONE CLOSER
TO THE FRONT OF THE OPERATOR. ON A
LEFT-HAND OPERATOR, THE OPEN LIMIT
SWITCH IS THE ONE FURTHEST AWAY
FROM THE FRONT OF THE OPERATOR.

GSLG-A OPERATOR INSTALLATION GUIDE

CONTROL BOARD ADJUSTMENTS

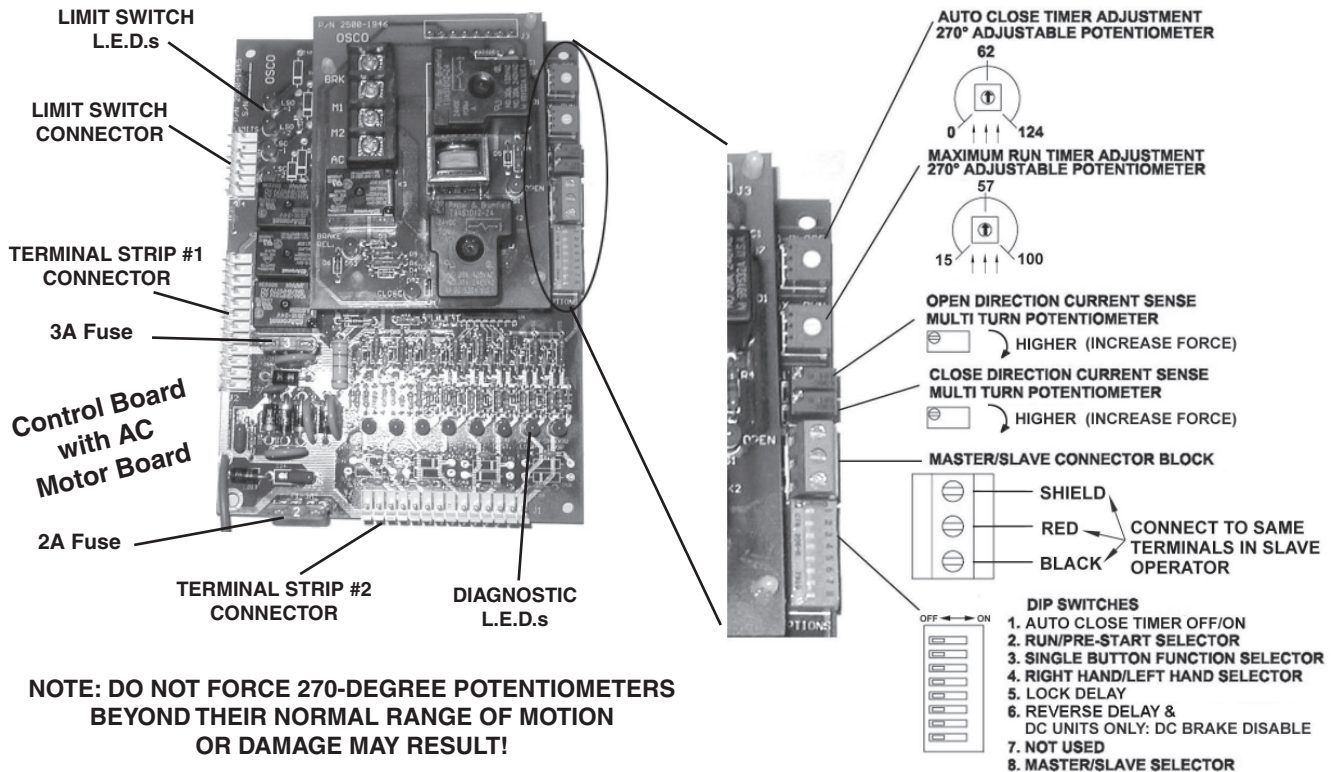

Auto Close Timer Adjustment: This 270-degree adjustable potentiometer will signal the operator to close automatically, provided no open, reversing or obstruction signals are present from the fully-open position. This timer is adjustable from 0 to 124 seconds. This feature is turned on or off using dip switch #1.

Maximum Run Timer Adjustment: This 270-degree adjustable potentiometer will signal the operator to stop running once it counts down, unless a limit switch is reached or an input is received first. Each time the motor starts, this timer will begin counting. This timer is adjustable from 15 to 100 seconds. If the timer expires, the unit locks out and the emergency alarm sounds.

Open Direction Current Sense Adjustment: This multi turn potentiometer is used to calibrate the built-in current sensing feature for detection of obstructions while running in the open direction.

Close Direction Current Sense Adjustment: This multi turn potentiometer is used to calibrate the built in current sensing feature for detection of obstructions while running in the closed direction.

Master/Slave Connection Block: This terminal block is used in conjunction with two operators to configure two gates to open and close together.

Dip Switches:

- #1 This switch turns the auto close timer off/on.
- #2 This switch is used in conjunction with alarms and flashing lights that may be added to the operator. When the switch is in the **ON** position, these devices will start approximately two seconds prior to the operator starting. In the **OFF** position, the devices will only work while the operator is running.
- #3 This switch is used in conjunction with single-button controls and radio receivers. In the **ON** position, successive inputs will cause signals in the order of **OPEN-STOP-CLOSE-STOP**. In the **OFF** position, inputs will cause an **OPEN** signal unless the gate is fully open, in which case it will signal **CLOSE**.
- #4 This switch determines right-hand vs. left-hand behavior. When looking from inside the protected area toward the gate, the side of the drive the operator is on determines its hand of operation. In the **OFF** position, the operator is set for right-hand.
- #5 When turned **ON**, this switch will allow a one-second delay for solenoid locks to unlock before the motor starts.
- #6 In the **ON** position the reverse delay is three (3) seconds. In the **OFF** position the reverse delay is one and a half (1 1/2) seconds.
- #7 Not used at this time.
- #8 This switch is used to set Master/Slave configuration. Operators which are stand-alone or master units should be set to **OFF**, while only slave units should have this switch set to **ON**.

GSLG-A OPERATOR INSTALLATION GUIDE

TERMINAL CONNECTION DESCRIPTIONS

| TERMINALS | FUNCTION | DESCRIPTION OF FUNCTION |
|------------------------|-------------------|------------------------------------------------------------------------------------------------------------------------------------------------------------------------------------------------------------------------------------------------------------------------------------------------------------------------------------------------------------------------------------------------------------------------------------------------------|
| 24VAC 24VAC N | 24VAC | Provides 24Volt AC power for accessories. Note: DC models will NOT have 24Volt AC power available. |
| 24VDC+ 24VDC- COMM. | 24VDC | Provides 24Volt DC power for accessories. |
| 1 & 4 | OPEN | Opens the operator. Several accessories such as button stations, keypads, transmitters and card readers can be wired to open. |
| 3 & 4 | CLOSE | Closes the operator. Use caution when wiring accessories to these terminals. The gate must be clearly visible from the location of any accessories wired to close. |
| 4 & 5 | SINGLE-BUTTON | Performs the single-button function which will alternate between open and close or open, stop and close - depending on dip switch #3. (See page 9 for details.) |
| 2 & 4 | STOP | Stops the operator. If no stop button is used, a jumper is required across 2&4 . |
| 4 & 6 | REVERSE | This function will cause a reversal when the gate is traveling closed and will travel back to the fully open position. Loop detectors are often wired for reverse. |
| 4 & 50 | OPEN OBSTRUCTION | This function works only while the operator is opening. Any signal to this function will cause the gate to stop, reverse a short distance, and then stop again. At this time the auto close timer is disabled, and a renewed input will be required to start the gate again. Should the gate be restarted and the signal occur again prior to reaching a limit, the gate will stop again, and this time will sound the emergency alarm and lock out. |
| 4 & 51 | CLOSE OBSTRUCTION | This function works exactly like the OPEN OBSTRUCTION, except that it will only work in the closing direction. |
| 4 & 11 | SHADOW/HOLD | This function will keep the gate in its fully open position while the signal is present. This is typically used with a loop and loop detector to keep a large swing gate open while vehicular traffic is passing through. |
| 24VDC+ & 60 | RUN/PRE-START | A 24Volt DC device such as a strobe light or alarm can be wired to these terminals. Depending on dip switch #2, these devices will either begin three seconds before the operator starts, or only while the motor is running. (See page 9 for details.) |

 **You must follow all required safety precautions and instructions at all times. Review the safety brochure included with the operator. If any pages are missing or unreadable, contact LINEAR at 1-800-333-1717 to request additional copies.**

 **Controls intended for user activation must be located at least six feet (6') away from any moving part of the gate and where the user is prevented from reaching over, under, around or through the gate to operate the controls. Outdoor or easily accessible controls shall have a security feature to prevent unauthorized use.**

 **Do not adjust the circuit board current sensing feature too high. It should be adjusted high enough to keep the gate from falsely triggering the sensing, but no higher than necessary for the gate to operate. Do not defeat the purpose of this function!**

GSLG-A OPERATOR INSTALLATION GUIDE

CURRENT SENSING ADJUSTMENTS

Because gates vary in construction and may have different force requirements in the open and close directions to move, the LINEAR control board has separate Multi-turn potentiometers for adjusting in both directions independently. The adjustment should be set light enough to maintain minimal force (50-75 lbs.) should an obstruction occur, but high enough to keep the gate moving under normal conditions without interruption.

Prior to adjusting the operator current sensing functions, make sure the gate moves freely in both directions. A badly aligned or poorly maintained gate may cause false triggering of the current sensor. Refer to page 9 when following the instructions below. A factory adjustment tool has been supplied to make these adjustments easier. This tool has been taped to the control box for your convenience.

CLOSE DIRECTION CURRENT SENSE ADJUSTMENT

When the gate operator leaves the factory, it has been preset for a relatively light gate function and will require additional adjustment. Begin by starting the gate going closed. If the operator stops and reverses, turn the close direction potentiometer (see page 9) one turn higher, press the **STOP** button, and try again. Repeat this process until the gate no longer causes false tripping of the current sensor. Note that each time the gate operator reverses, the **STOP** button must be pressed. Next, turn the close direction potentiometer lower slowly while the operator is running the gate closed until the gate operator stops and reverses again. From this point, turn the close direction potentiometer higher by 1 1/2 turns for all 115 Volt AC and 24 Volt DC operators, and by 3/4 of a turn higher for all 230 Volt AC operators. Additional fine adjustment by 1/4 turns may be necessary to eliminate false triggering.

OPEN DIRECTION CURRENT SENSE ADJUSTMENT

Repeat the same process with the open direction potentiometer while running the gate in the open direction. Once this is done, run the gate through several complete cycles and make sure the gate does not false trip in either direction.

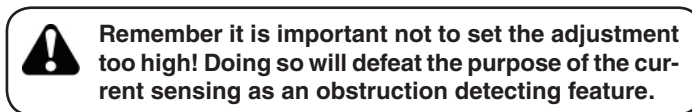
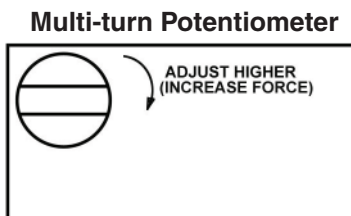

MAXIMUM RUN TIMER ADJUSTMENT

This adjustable potentiometer sets the maximum length of time the motor will run before shutting down. It should be configured for the time it takes to run the gate fully open or closed, plus an additional 15 seconds. See page 9 for details.

AUTO CLOSE TIMER ADJUSTMENT

This adjustable potentiometer sets the length of time which elapses before the gate operator automatically closes the gate, from the fully open position, provided no open, reversing, or obstruction signals are present. This feature can be turned on or off via dip switch selection. See page 9 for details. **Do not use the auto close timer without an appropriate reversing device installed!**

MASTER/SLAVE CONNECTION

A three-wire shielded conductor cable is required to connect master and slave operators. You must use Belden 8760 Twisted Pair Shielded Cable (or equivalent) **only** – LINEAR part number 2500-1982, per foot). See page 9 for details of this connection, as well as dip switch selection. Note: The SHIELD wire should be connected in both the master and slave operators. **In addition, you must run power to both the master and slave operators.**

GSLG-A OPERATOR INSTALLATION GUIDE

ONBOARD L.E.D. INDICATOR DESCRIPTIONS

Control Board L.E.D. Indicators:

| | |
|---------------------------------|---------------------------------------------------------------------------------------------------------------------------------------------------------------------------------------------------------------------------------------------------------------------------------------|
| OPEN | This indicator is lit when an open signal is present. This signal can come from such devices as button stations, radio receivers, keypads and telephone entry systems. |
| CLOSE | This indicator is lit when a closed signal is present. This signal typically comes from three-button stations. |
| STOP | This indicator is lit when there is a break in the stop circuit. Make sure there is a stop button wired in and working properly. |
| SINGLE | This indicator is lit when a signal from a single-button station or radio receiver is present. |
| CLOSE OBST | This indicator is lit when a close obstruction signal is present. This signal can come from edges and photo eyes which have been wired to the close obstruction inputs. |
| OPEN OBST | This indicator is lit when an open obstruction signal is present. This signal can come from edges and photo eyes which have been wired to the open obstruction inputs. |
| SAFETY LOOP | This indicator is lit when a reversing signal is present. This signal is generated by a loop detector wired to the safety loop terminals. |
| SHADOW LOOP | This indicator is lit when a shadow/hold open signal is present. This signal is generated by a loop detector wired to the shadow loop terminals. |
| <u>LH</u> <u>RH</u> | |
| LSC-1 LSO-1 | This indicator is lit when the open #1 limit switch is activated on a right-hand operator, or the close #1 switch on a left-hand. If this indicator is lit and the gate is not in its full open/closed position, the limit may need adjusting or the limit switch may need replacing. |
| LSC-2 LSO-2 | This indicator is lit when the open #2 limit switch is activated on a right-hand operator, or the close #2 switch on a left-hand. |
| LSO-1 LSC-1 | This indicator is lit when the close #1 limit switch is activated on a right-hand operator, or the open #1 on a left-hand. If this indicator is lit and the gate is not in its full open/closed position, the limit may need adjusting or the limit switch may need replacing. |
| LSO-2 LSC-2 | This indicator is lit when the close #2 limit switch is activated on a right-hand operator, or the open #2 switch on a left-hand. |

Motor Board L.E.D. Indicators:

| | |
|--------------------|--------------------------------------------------------------------------------------------------------------------------------------------------|
| NON LABELED | One of these two indicators will be lit when the motor is running the gate open, and the other is lit when the motor is running the gate closed. |
| BRAKE REL. | This indicator is lit when the brake is NOT applied. |

GSLG-A OPERATOR INSTALLATION GUIDE

IMPORTANT NOTES FOR INSTALLATION OF MASTER/SLAVE APPLICATIONS

When setting up Master/Slave gate operators, it is best to make adjustments and run each operator individually. To do this, simply:

- a. Set Dip Switch #4 to proper hand of operation (right-hand or left-hand)
- b. Set Dip Switch #8 as Master (off)

Run each operator making current sensing adjustments as necessary, as indicated on the Control Board Adjustments page of this installation guide. When both operators have been adjusted, turn power off, then turn on Dip Switch #8 in the operator chosen as the Slave.

The timer to close and radio/single button behavior are set in the Master operator.

The following selections are set individually:

- Current Sensing
- Maximum Run Timer
- One-Second Lock Release
- Three-Second Pre-Start Warning
- Right/Left-Hand Selections

SURGE PROTECTOR INSTRUCTIONS

The optional surge protector should be connected to any inputs that have an accessory connected to it. This includes the 3-button station, so it must be connected to 1, 2A and 3 in all cases. The green wire connected to ground, which is electrically the same as terminal 4. The red wires connect to terminals 2A and 24VDC+. This will cause the 2 amp fuse to blow if this section of the module becomes shorted. With any of the other inputs connected to the surge protector, if their protection line becomes shorted due to a surge over the rating of the module, the corresponding LED on the main board will remain lit, causing a constant signal to the controller. If this is found, please replace the entire surge protector with a new unit.

Do not simply unhook the shorted wire, as this removes the protection from the circuit that was saved by the protector in the first place!

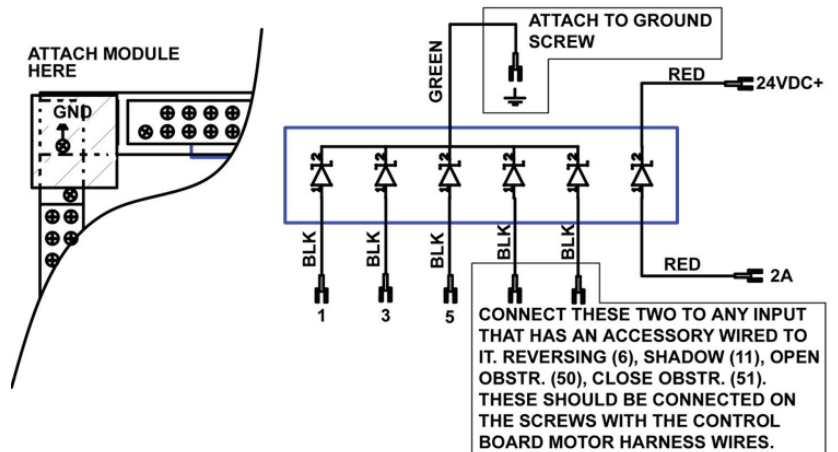

GSLG-A OPERATOR INSTALLATION GUIDE

CONTROL and ACCESSORY CONNECTION ILLUSTRATIONS

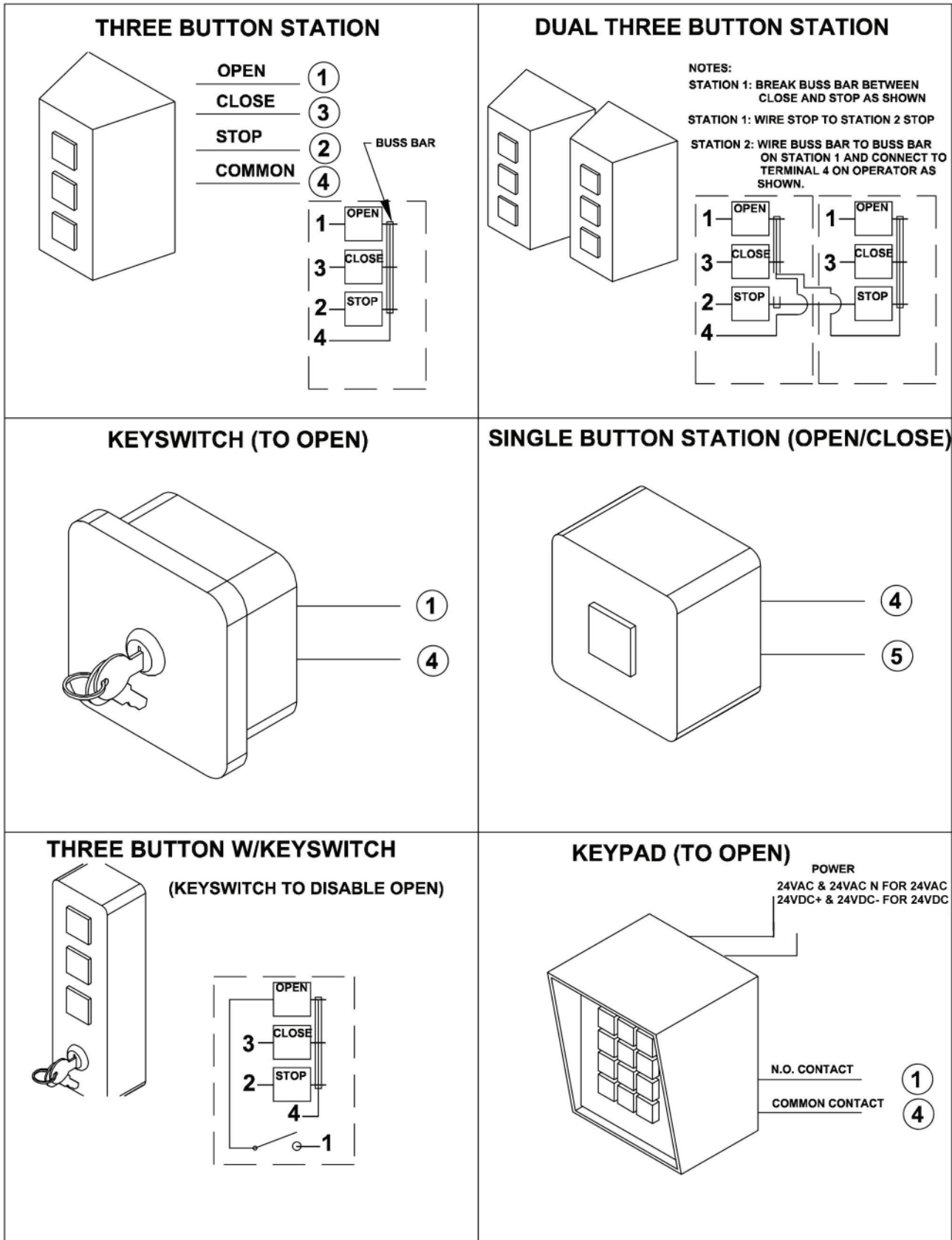

GSLG-A OPERATOR INSTALLATION GUIDE

CONTROL and ACCESSORY CONNECTION ILLUSTRATIONS

TELEPHONE ENTRY SYSTEM (TO OPEN)

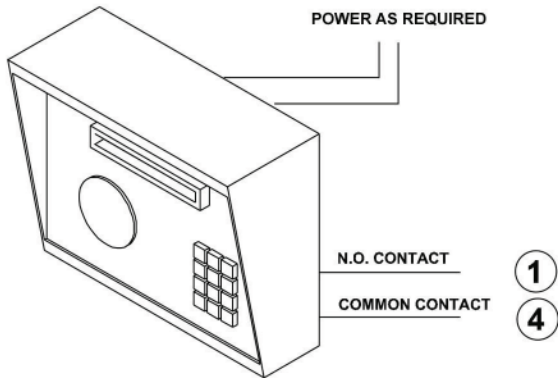

CARD READER (TO OPEN)

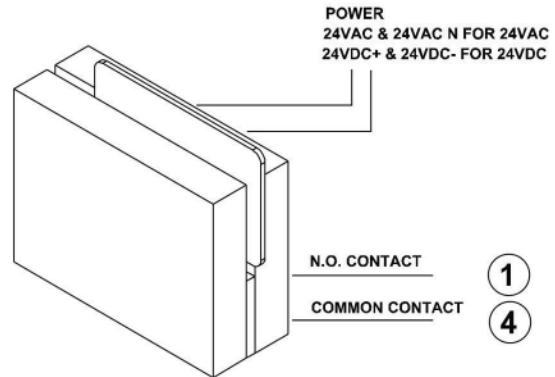

STROBE (WIRED FOR RUN)

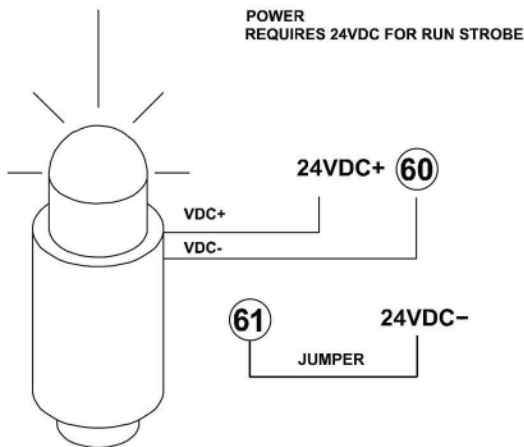

FOUR WIRE RECEIVER (OPEN/CLOSE)

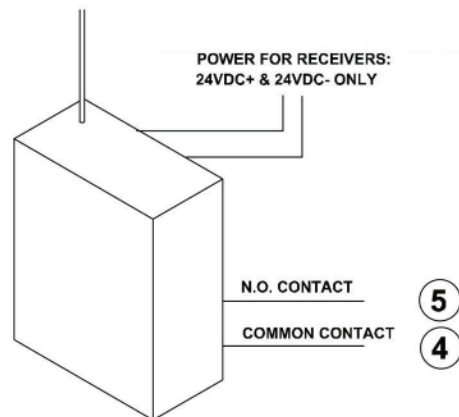

AUXILIARY SIGNALING DEVICE 24VDC

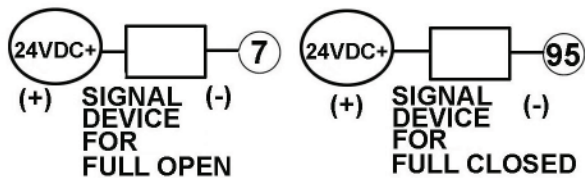

SHOWN FOR RIGHT HAND INSTALLATION;
LEFT HAND OPPOSITE

FOR OTHER VOLTAGES, AN OPTIONAL 24VDC
RELAY IS REQUIRED. CONSULT THE
FACTORY.

TWO CHANNEL RECEIVER (OPEN/CLOSE)

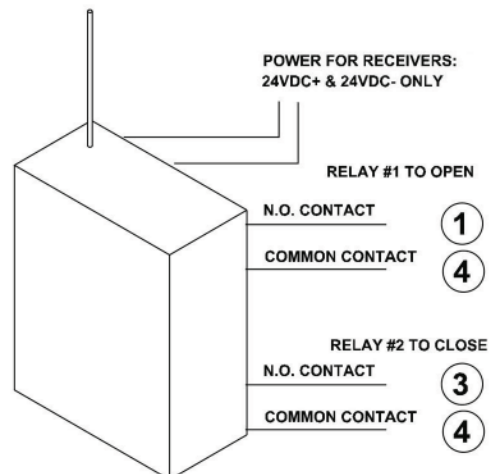

GSLG-A OPERATOR INSTALLATION GUIDE

CONTROL and ACCESSORY CONNECTION ILLUSTRATIONS

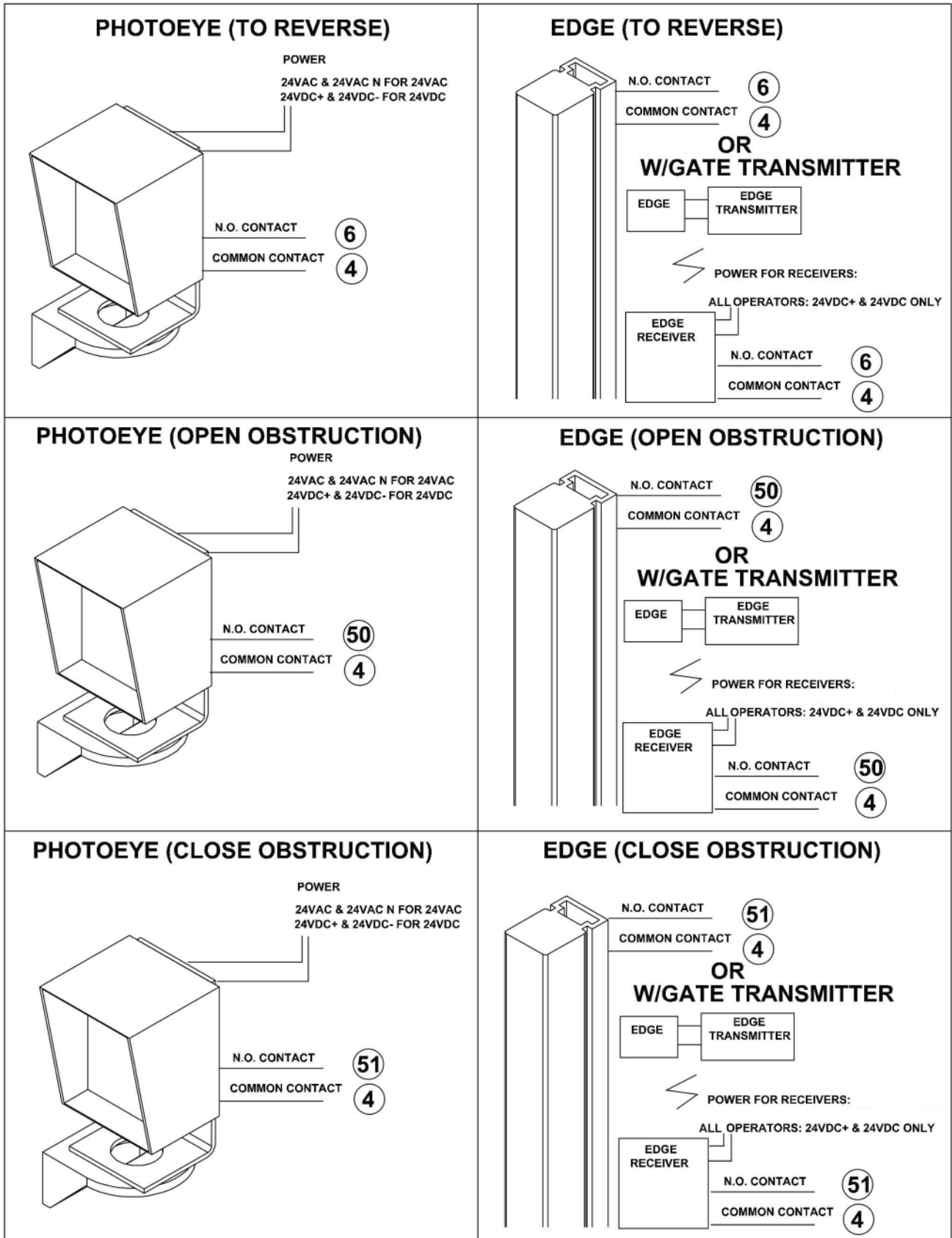

GSLG-A OPERATOR INSTALLATION GUIDE

CONTROL and ACCESSORY CONNECTION ILLUSTRATIONS

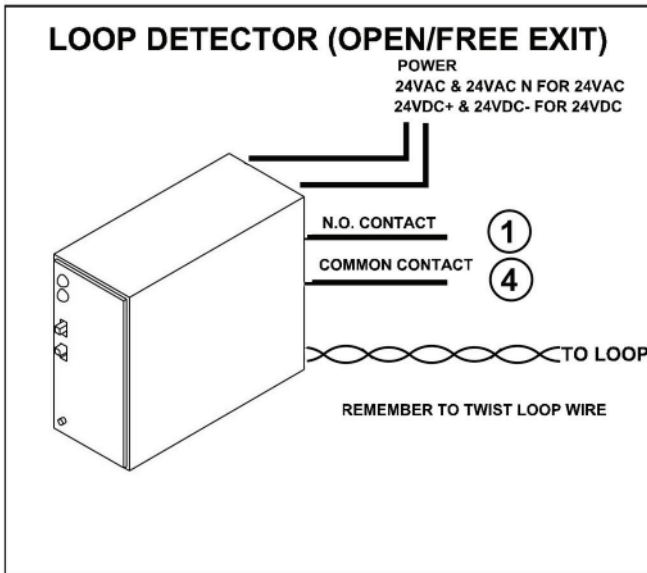

WIRES 17, 18, AND 19 ARE LOCATED IN THE MIDDLE OF THE J2 CONNECTOR

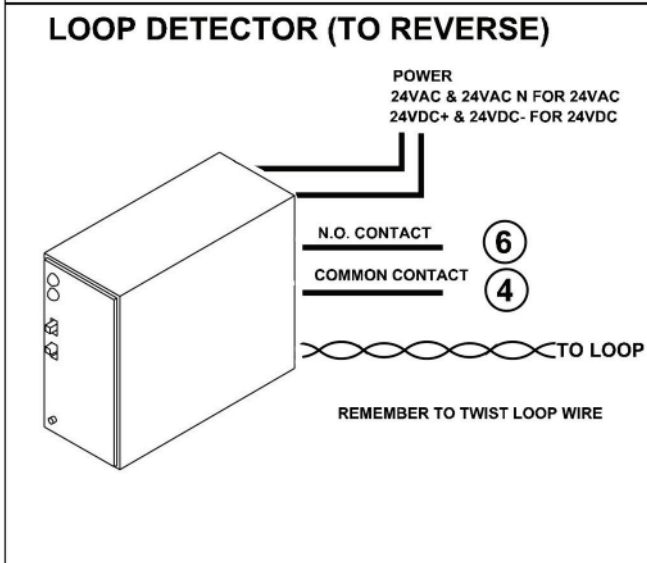
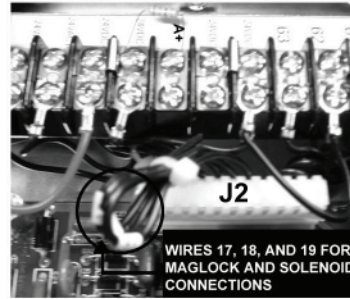

SOLENOID LOCK

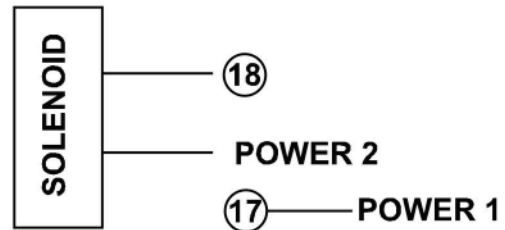

MAKE SURE TO MATCH POWER VOLTAGE TO LOCK RATING (17 & 18 ARE NORMALLY OPEN CONTACTS, 10 AMP RATING)

24VDC MAGLOCK

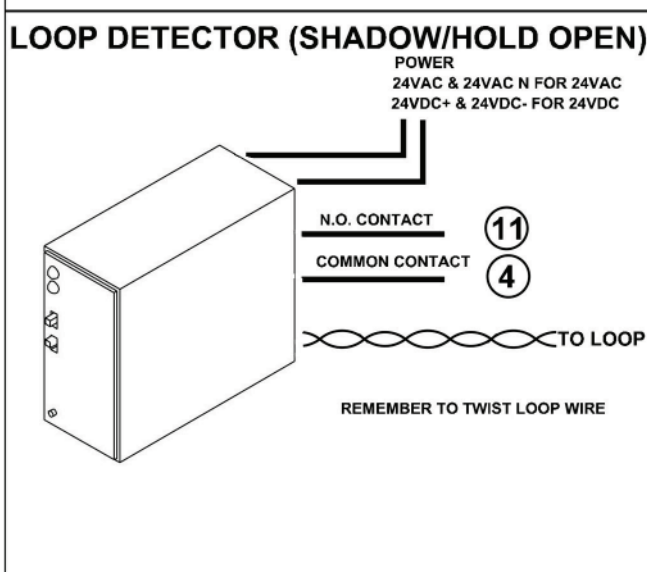
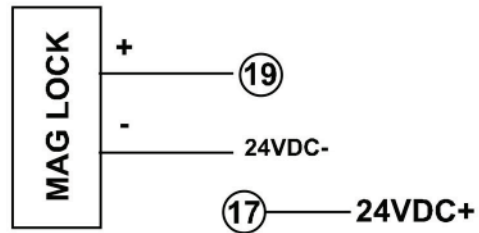

HEATER ASSEMBLIES (AC MODELS ONLY)

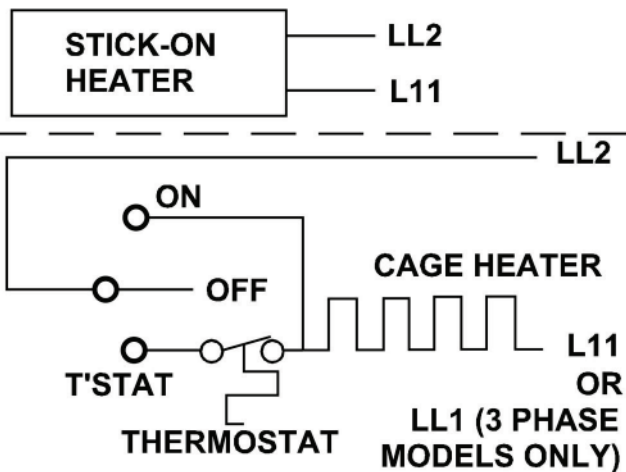

GSLG-A OPERATOR INSTALLATION GUIDE

LOOP LAYOUT ILLUSTRATION

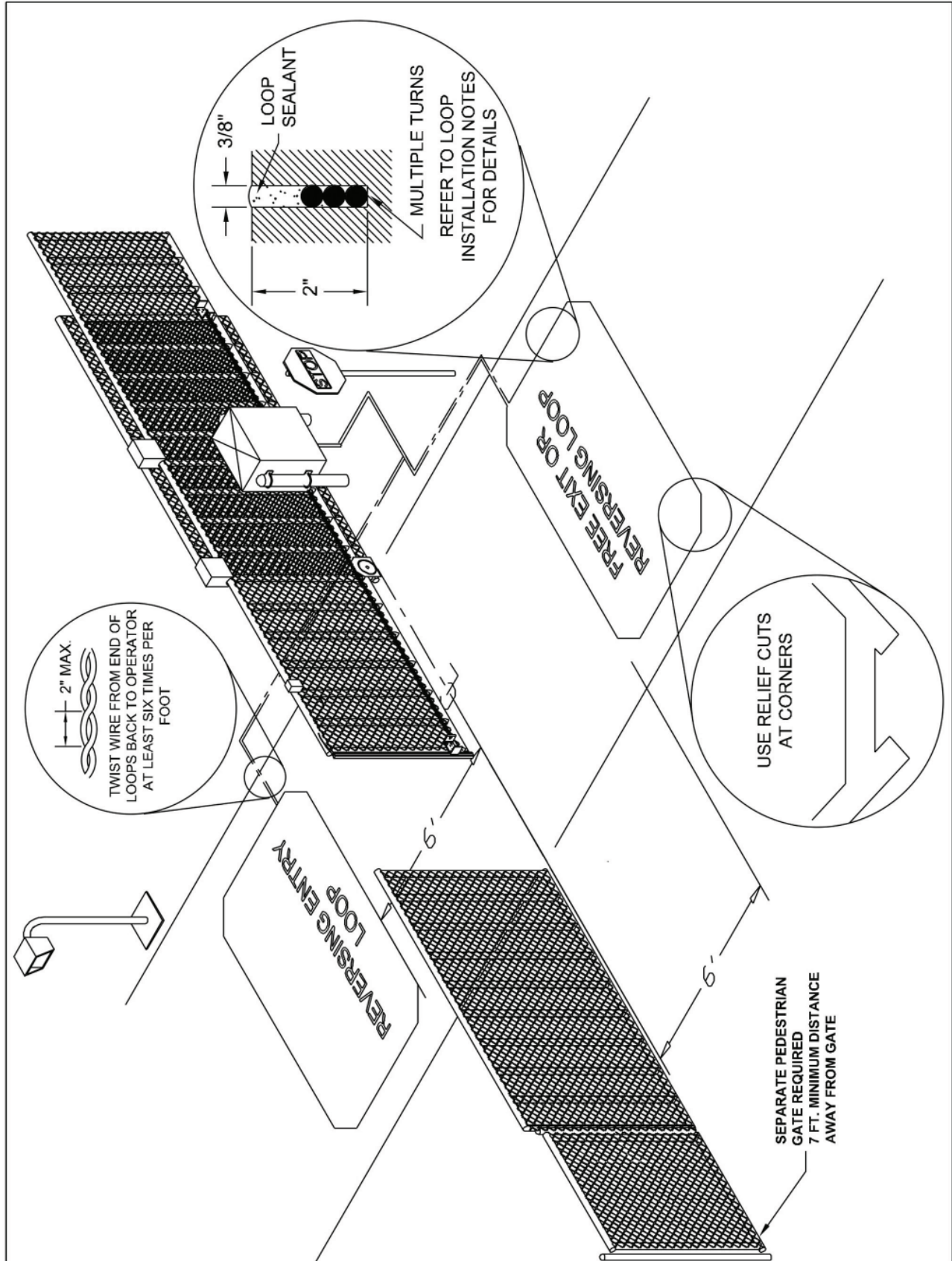

Refer to Connection Descriptions on page 10 and Loop Accessory Connections on page 17 for details.

GSLG-A OPERATOR INSTALLATION GUIDE

EDGE LAYOUT ILLUSTRATION #1

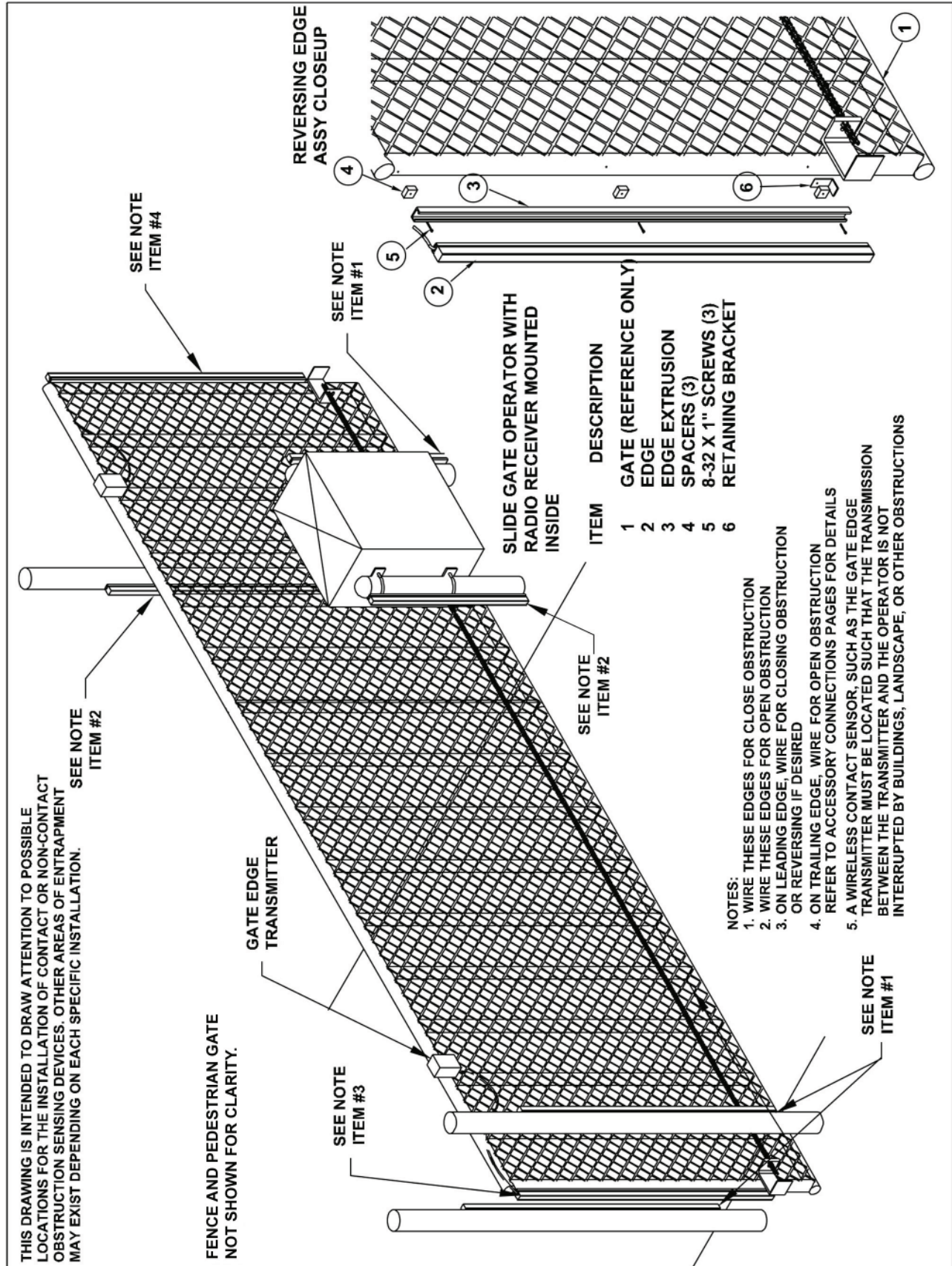

Refer to Connection Descriptions on page 10 and Contact Edge Connections on page 16 for details.

GSLG-A OPERATOR INSTALLATION GUIDE

EDGE LAYOUT ILLUSTRATION #2

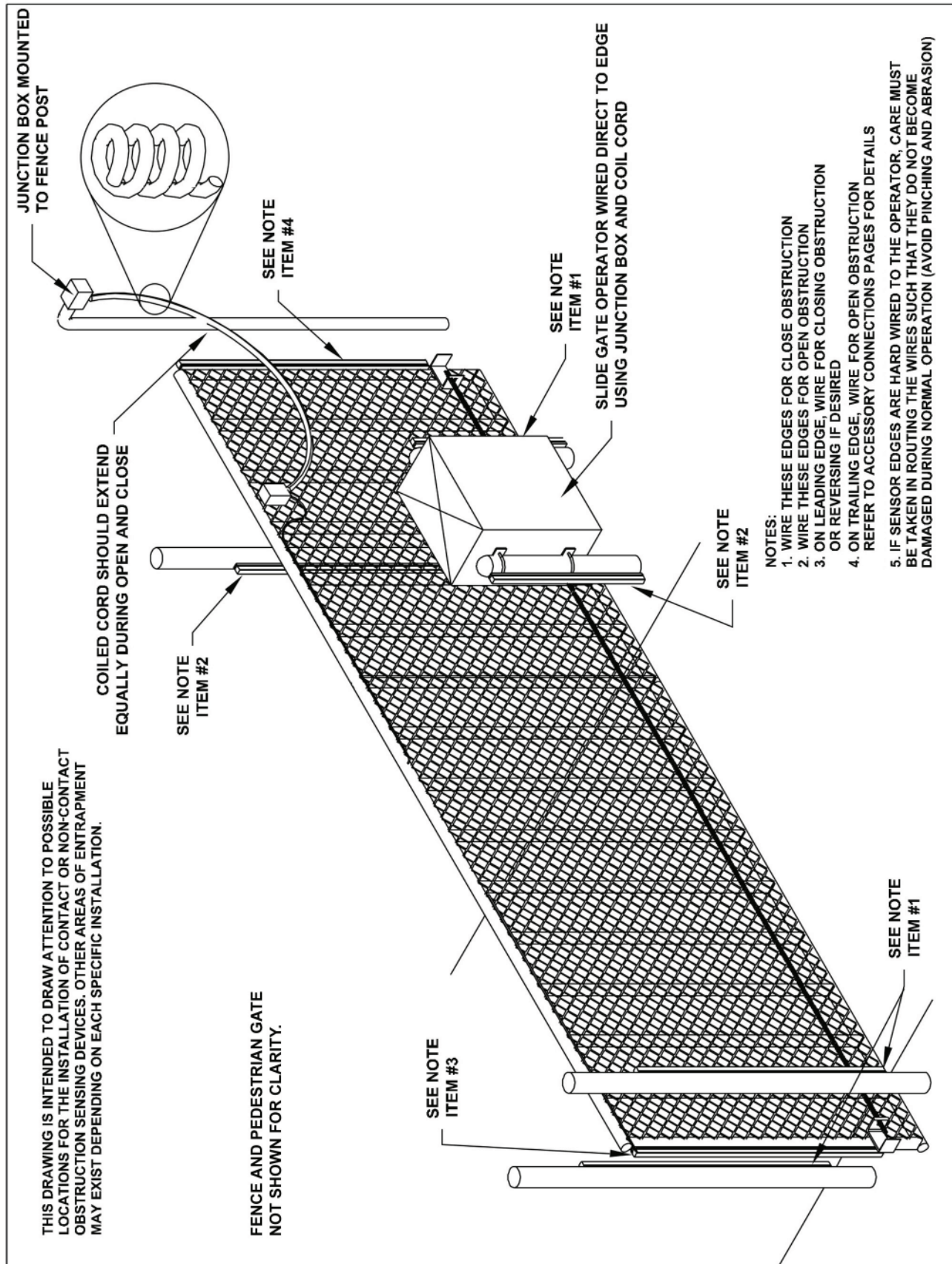

Refer to Connection Descriptions on page 10 and Contact Edge Connections on page 16 for details.

GSLG-A OPERATOR INSTALLATION GUIDE

PHOTO EYE ILLUSTRATION

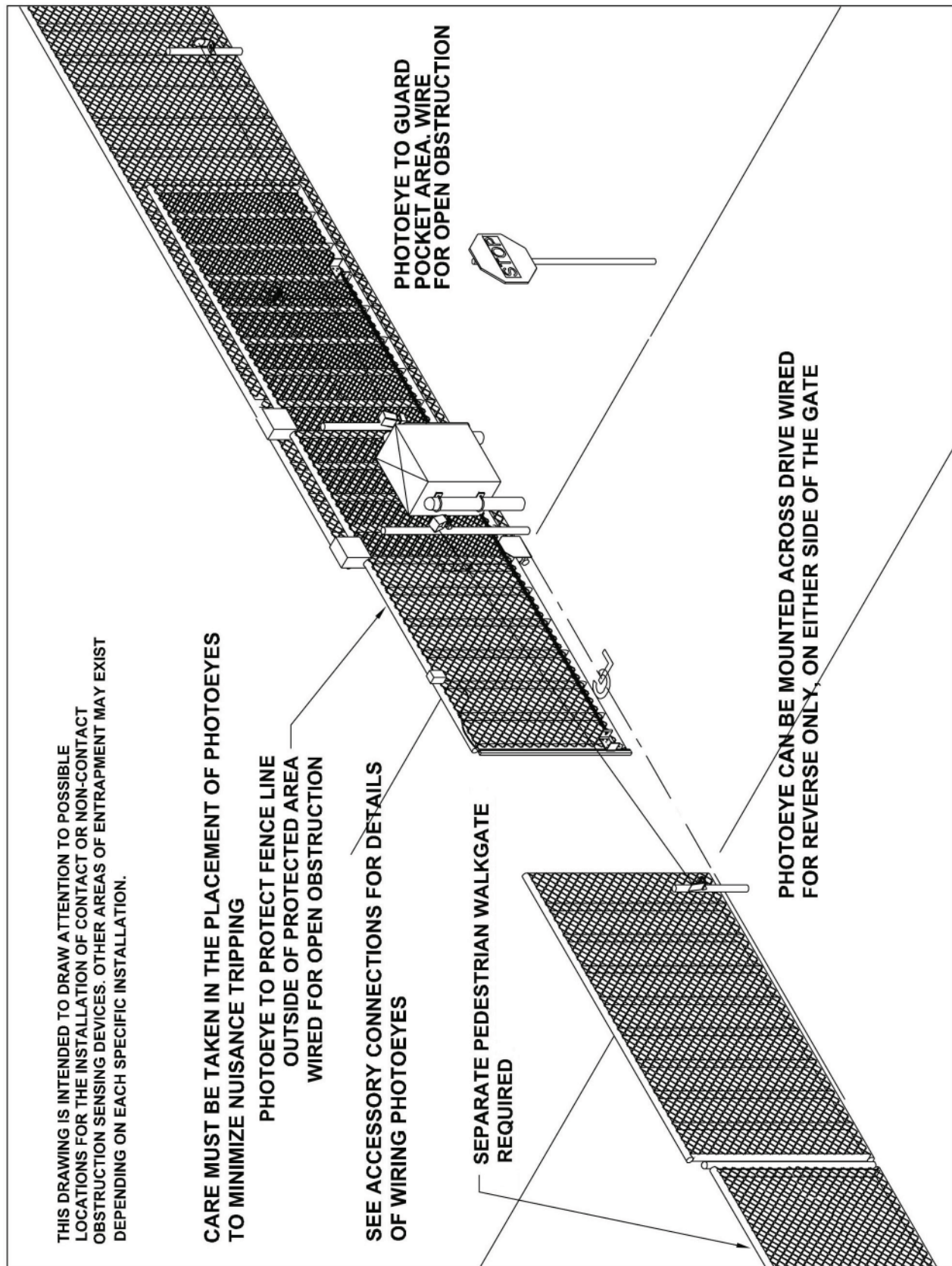

Refer to Connection Descriptions on page 10 and Photo Eye Connections on page 16 for details.

GSLG-A OPERATOR INSTALLATION GUIDE

PICKET GATE ILLUSTRATION

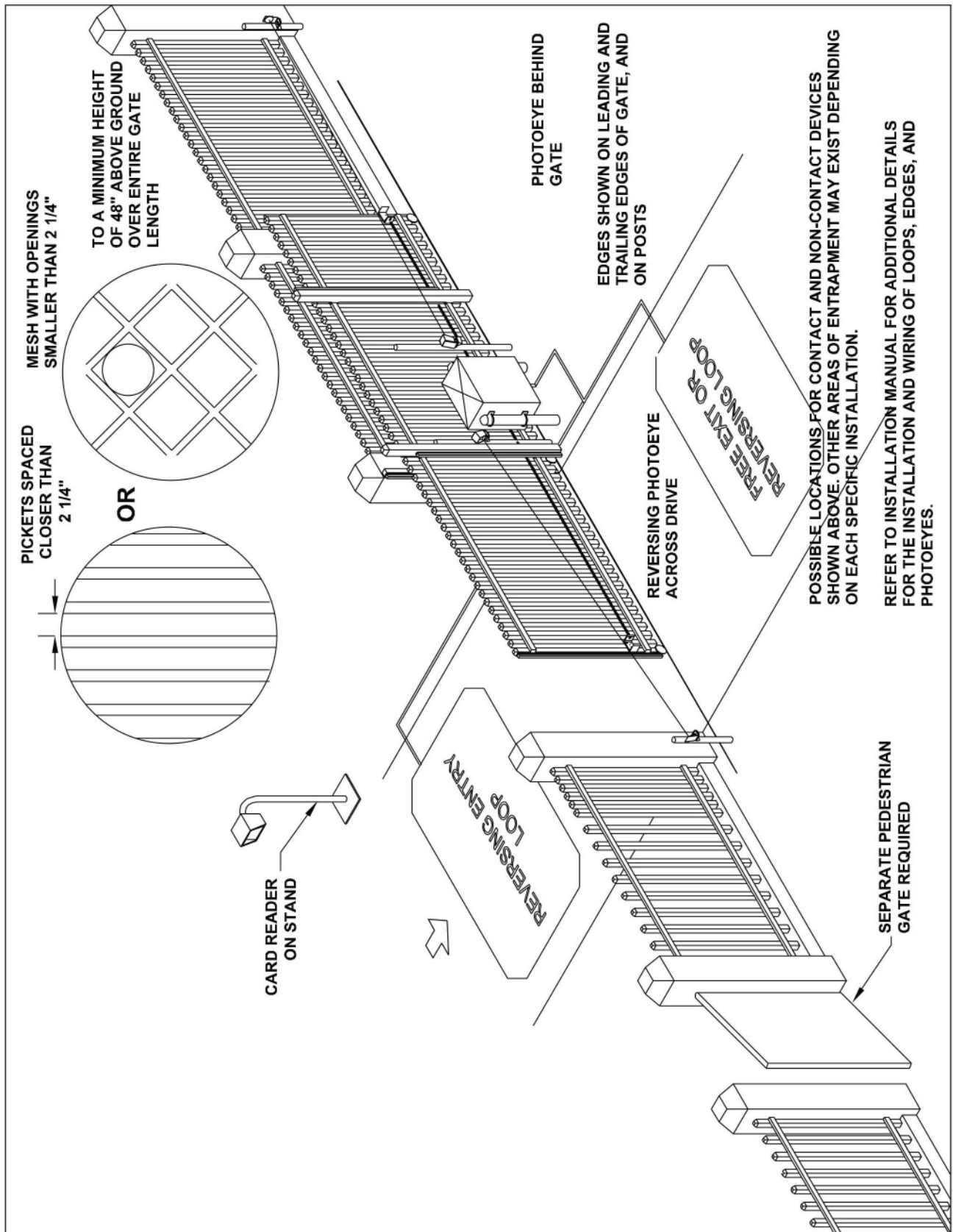

Refer to Connection Descriptions on page 10 and Accessory Connections on pages 14-17 for additional details.

GSLG-A OPERATOR INSTALLATION GUIDE

TRACK GATE ILLUSTRATION

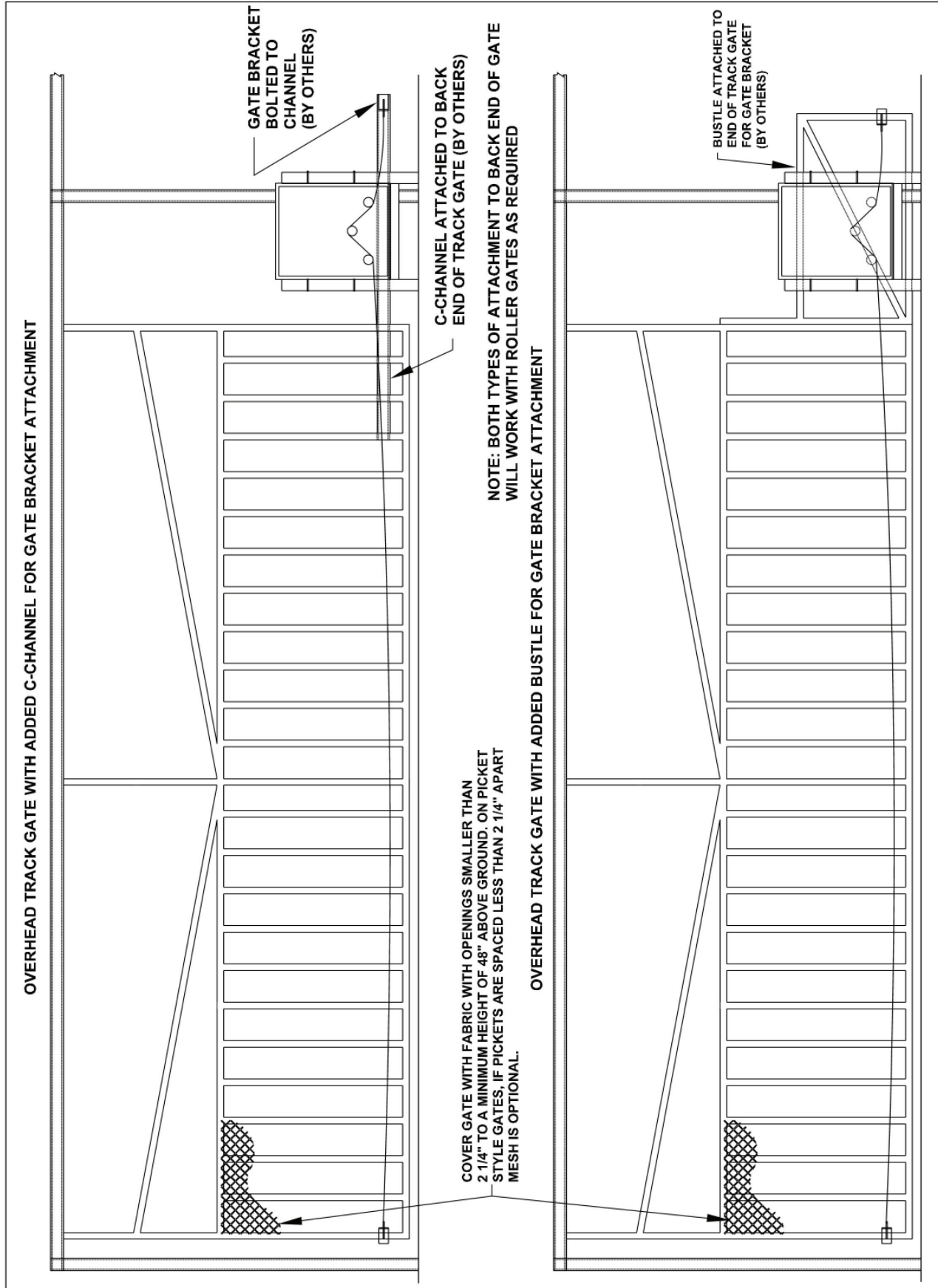

GSLG-A OPERATOR INSTALLATION GUIDE

TROUBLESHOOTING

Operator fails to start:

- A. If the operator has been running a large number of cycles, the motor may have gotten hot and tripped the overload. Allow the motor to cool down and the overload will reset automatically.
- B. Make sure you have power at the master distribution panel and that the power has not been turned off.
- C. The secondary fuse on the control board may have blown. Replace the fuse (refer to control box parts list on page 26 for part number information).

Motor operates, but gate does not move:

- A. In operators with torque limiters and friction pad clutches, check for signs of slipping. You can mark the sprocket and clutch with a yellow or white grease pen and watch for the lines to move apart if slipping is taking place. Adjust the torque limiter tighter if this is the problem.
- B. Check for broken chain or worn belts.
- C. Check all setscrews on pulleys and sprockets and tighten them if necessary, and check for keys which may have fallen loose from keyways.

Motor sounds like it is working harder than normal:

- A. Make sure the gate is moving freely and without binding throughout its entire travel.
- B. Check the drive chain for obstructions (if the operator has one).
- C. If the operator has an internal brake mechanism, make sure it is releasing.

Limit switch getting out of time:

- A. Check for proper tension on all limit chains to be sure there is no jumping taking place. Mark one tooth and its corresponding link and run the gate. If the marks have moved, the chain is skipping.
- B. Check the setscrews in limit cams and limit sprockets for tightness. In rotary limit boxes, check the rotary limit nut for sloppiness or stripped threads. Replace if necessary.
- C. Check the chain tension along the output sprocket and idlers. Mark the chain and one tooth of the sprocket as described above and run the gate. Check for jumping.

Gate stopping part way open or closed (but no visible obstruction):

- A. The control board may have received a false obstruction input triggered by current sensing set too low. Make sure the gate moves freely through its entire travel before adjusting the current sensing.
- B. The maximum run timer may have counted down and expired. This can be caused by having the timer set too low, if a chain or belt is broken, or if a sprocket or pulley is slipping. When the timer expires, the gate stops and an alarm will sound.
- C. An obstruction signal from an accessory wired to the obstruction input may have triggered falsely. Check the control board for lit L.E.D. indicators for any of the following inputs: safety, shadow, open obstruction, close obstruction, stop, etc. If any are lit when the operator should be running, remove all devices hooked to that function and hook them up one at a time and try to run the operator until the problem device is found. Refer to page 12 for details on the control board indicators.

Gate staying open with automatic system:

- A. If there are vehicle detectors in your machine which are set up for reverse, one of your loops or loop detectors may be sending a false signal. Disconnect the wire harness and try running the operator.
- B. An opening or reversing device may be stuck or malfunctioning. Try disconnecting these devices and hook them back up one at a time and try running the operator until the malfunctioning device is found.
- C. Make sure the close limit switch isn't activated. If it is, the operator will think the gate is already closed.
- D. Make sure operator is on full open limit switch, unless close from any position is enabled. See wiring diagram.
- E. If the stop or reset button is pressed, the timer is disabled until another run command is received.

HOW TO ORDER REPLACEMENT PARTS

Use the part numbers listed on the following pages. Contact your **local LINEAR dealer** or **distributor** to order parts.

1. Supply the model number and serial number of your operator.
2. Specify the quantity of pieces needed and order by part number and name of part.
3. State whether to ship by freight, truck, parcel post, UPS or air express.
4. State whether transportation charges are to be prepaid or collect.
5. Specify name and address of person or company to whom parts are to be shipped.
6. Specify name and address of person or company to whom invoice is to be sent.

GSLG-A OPERATOR INSTALLATION GUIDE

MODEL **GSLG-A** MECHANICAL PARTS EXPLODED VIEW

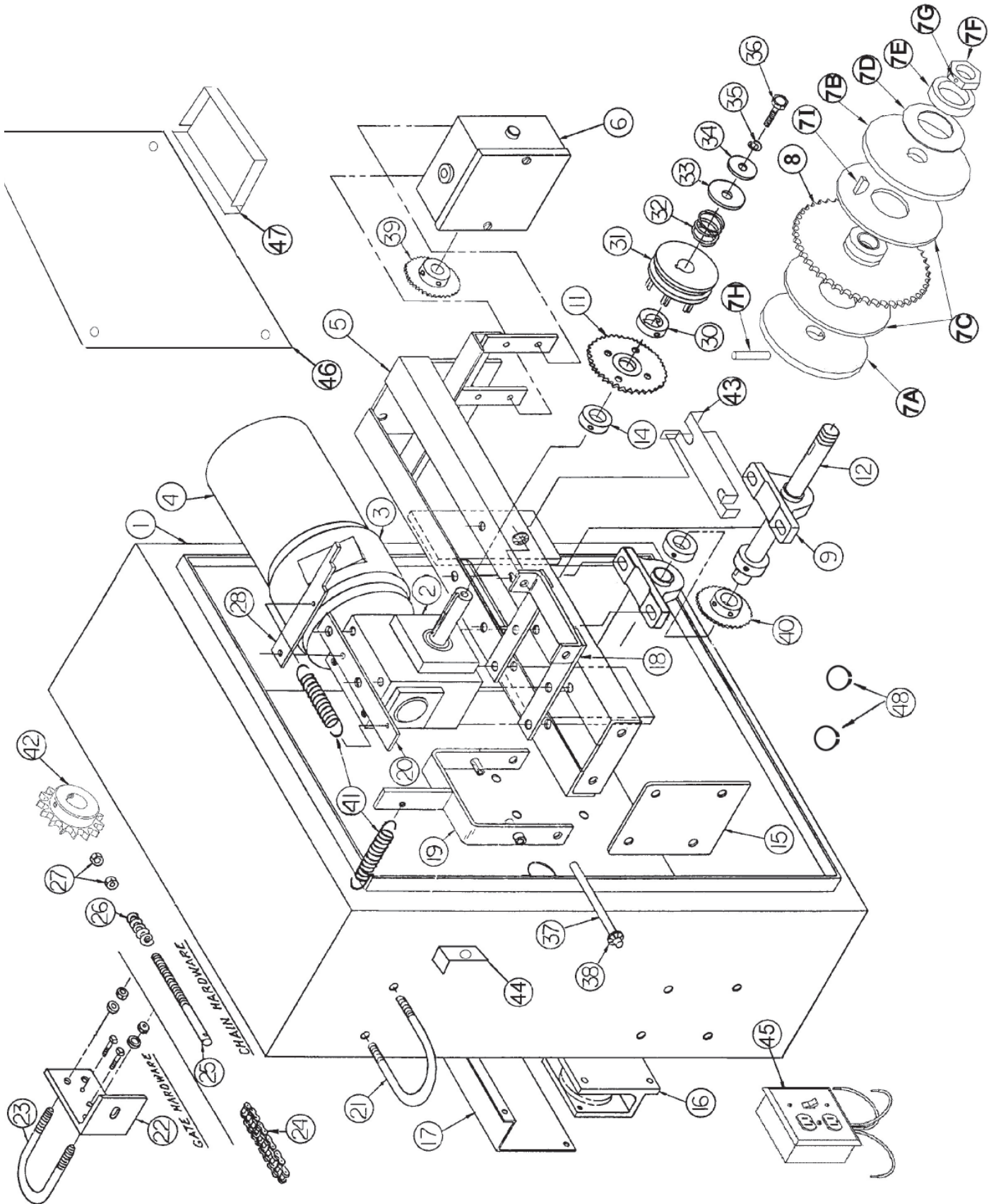

GSLG-A OPERATOR INSTALLATION GUIDE

MODEL **GSLG-A** MECHANICAL PARTS LIST

| REF NO. | PART NO. | DESCRIPTION | REF NO. | PART NO. | DESCRIPTION |
|---------|-------------|----------------------------------------------------------------------|---------|-------------|----------------------------------------------|
| 1 | 2120-359-BT | Complete Enclosure with Door Assembly | 46 | 2100-1756 | Mounting Plate |
| | 2120-144-BT | Enclosure without Door | 47 | 2100-1781 | Accessory Shelf for single phase models only |
| | 2120-360-BT | Complete Door and Lock Assembly | 33 | 2400-308 | Fender Washer, 3/8" |
| | 2300-716 | Stop/Reset Button Cover | 34 | 2400-017 | Flat Washer, 3/8" |
| | 2500-2192 | C-Face Brake, 115V | 35 | 2400-016 | Lock Washer, 3/8" |
| | 2500-2397 | C-Face Brake, 208/230/460V | 36 | 2400-014 | HHCS, 3/8"-16 x 1" |
| 5 | 2110-265 | Rail Assembly | 16 | 2110-700 | Idler Assembly |
| 15 | 2100-573 | Spacer Plate | | 2300-697 | UHMW Idler Wheel |
| | 2100-661 | Back Brace | | 2100-1731 | Idler Shaft |
| 12 | 2100-1738 | Drive Shaft, 1" | 6 | 2520-173L | Rotary Limit Box Assembly |
| 48 | 2400-501 | Retaining Ring | | 2500-764 | Limit Switch |
| | | | | 2100-057 | Standard Limit Shaft |
| 9 | 2200-274 | Bearing, 1" | | 2200-030 | Limit Nut |
| 43 | 2100-1737 | Pillow Block Retaining Plate | | 2100-261 | Detent Plate |
| 40 | 2200-042 | Sprocket, 48 B 15, 1" bore | | 2110-162 | Limit Box Enclosure with Cover |
| | 2200-015 | Shaft Collar, 1" | | 2100-756 | Limit Box Cover only |
| 7 | 2120-388 | Torque Limiter Assembly, 5 1/2" | | 2200-029 | Flange Bearing, 1/2" ID |
| 7A | 2100-1650 | Plate with Solid Pin Groove | | 2200-193 | E-Ring, 1/2" |
| 7B | 2100-1661 | Keyed Plate | | 2400-203 | Spring Washer, 1/2" |
| 7C | 2300-390 | Friction Disc (pair) | | 2200-042 | Limit Drive Sprocket, 48-B-15, 1" bore |
| 7D | 2200-817 | Belleville Washer | | | <i>For drives up to 34 feet wide:</i> |
| 7E | 2100-1621 | Belleville Washer Retaining Disc | 39 | 2200-008 | Limit Box Sprocket, 48-B-10, 1/2" bore |
| 7F | 2100-1622 | Adjustment Nut | | 2200-922 | #48 Chain, 25 Links |
| 7G | 2400-407 | Brass Tipped Set Screw | | | <i>For drives from 35 to 49 feet wide:</i> |
| 7H | 2400-416 | Dowel Pin | | 2200-041 | Limit Box Sprocket, 48-B-15, 1/2" bore |
| 7I | 2100-529 | Woodruff Key | | 2200-200 | #48 Chain, per foot, 27 Links |
| 8 | 2210-004 | Sprocket, 40-A-48, with Bearing | | 2200-276 | <i>For drives 50 to 65 feet wide:</i> |
| 42 | 2200-886 | Drive Sprocket, 50-B-20, 1" Bore | | 2200-654 | Limit Box Sprocket, 48-B-20, 1/2" bore |
| | | | | | #48 Chain, per foot, 29 Links required |
| | 2110-788 | Gear Reducer/Disconnect Assembly | | 2200-432 | <i>For drives over 65 feet wide:</i> |
| 2 | 2200-920 | Gear Reducer, 15:1 | | 2200-654 | Limit Box Sprocket, 48-B-30, 1/2" bore |
| 19 | 2120-132 | Shifter Lever Assembly | | | #48 Chain, per foot, 32 links required |
| 18 | 2110-362 | Shifter Lever Fulcrum Assembly | | 2200-010 | #48 Master Link |
| 37 | 2100-551 | Shifter Lever Rod | | | |
| 38 | 2400-169 | Pal Nut | | 2200-605 | #40 Chain, 37 Links |
| 20 | 2100-1133 | Locking Lever Plate | | 2200-006 | #40 Master Link |
| 28 | 2100-910 | Locking Lever | 17 | 2100-657-BT | Rain Cover |
| 41 | 2200-291 | Shifter and Locking Lever Spring | 24 | 2200-221 | #50 Roller Chain, per foot |
| 14 | 2200-014 | Shaft Collar, 1" | | 2200-111 | #50 Master Link |
| 11 | 2110-364 | Sprocket, 40 A 24, with Bearing | 25 | 2100-258 | Chain Pin |
| 30 | 2200-549 | Disconnect Collar, 1" (keyed) | 26 | 2200-306 | Tension Spring |
| 31 | 2110-131 | Shifter Block | 22 | 2100-2007 | Gate Bracket |
| | 2400-133 | Key, 1/4" x 1/4" x 2 1/4" | 27 | 2400-090 | Hex Nut, 1/2" |
| 32 | 2200-115 | Disconnect Spring | 23 | 2400-170 | Gate U-Bolt |
| 44 | 2510-248 | Stop/Reset Button & Bracket Assembly | 21 | 2400-038 | Mounting U-Bolt |
| | 2100-1760 | Stop/Reset Button Mounting Bracket | | 2500-867 | Alarm, 24VAC |
| | 2500-1495 | Stop/Reset Button | | 2510-064 | 3-Button Station with Lead Wires |
| 45 | 2510-251-D | Power On/Off Disconnect Assembly with Receptacles (115V Models only) | 4 | 2500-2307 | C-Face Motors |
| | 2500-1956 | 115VAC Duplex Receptacles only | | 2500-2308 | 1/2 HP, 115V, 1 Phase |
| | 2500-1957 | 115VAC Switch only | | 2500-2309 | 1/2 HP, 208/230V, 1 Phase |
| | 2510-252-D | Power On/Off Disconnect Assembly for 230V Models | | 2500-2310 | 3/4 HP, 115V, 1 Phase |
| | 2500-2205 | 230VAC Switch only | | 2500-2311 | 3/4 HP, 208/230V, 1 Phase |
| | 2510-294 | Power On/Off Disconnect Assembly for 3-Phase Operators | | 2500-2312 | 1 HP, 115V, 1 Phase |
| | 2500-034 | Power Switch only | | 2500-2313 | 1 HP, 208/230V, 1 Phase |
| | | | | 2500-2314 | 1/2 HP, 208/230/460V, 3 Phase |
| | | | | 2500-2315 | 3/4 HP, 208/230/460V, 3 Phase |
| | | | | 2500-2315 | 1 HP, 208/230/460V, 3 Phase |
| | | | | | Capacitors |
| | | | | 2500-2336 | Capacitor for 2500-2307 Motor |
| | | | | 2500-2337 | Capacitor for 2500-2308 Motor |
| | | | | 2500-1926 | Capacitor #1 for 2500-2309 Motor |
| | | | | 2500-1930 | Capacitor #2 for 2500-2309 Motor |
| | | | | 2500-1931 | Capacitor for 2500-2310 Motor |
| | | | | 2500-2338 | Capacitor for 2500-2311 Motor |
| | | | | 2500-1932 | Capacitor for 2500-2312 Motor |

GSLG-A OPERATOR INSTALLATION GUIDE

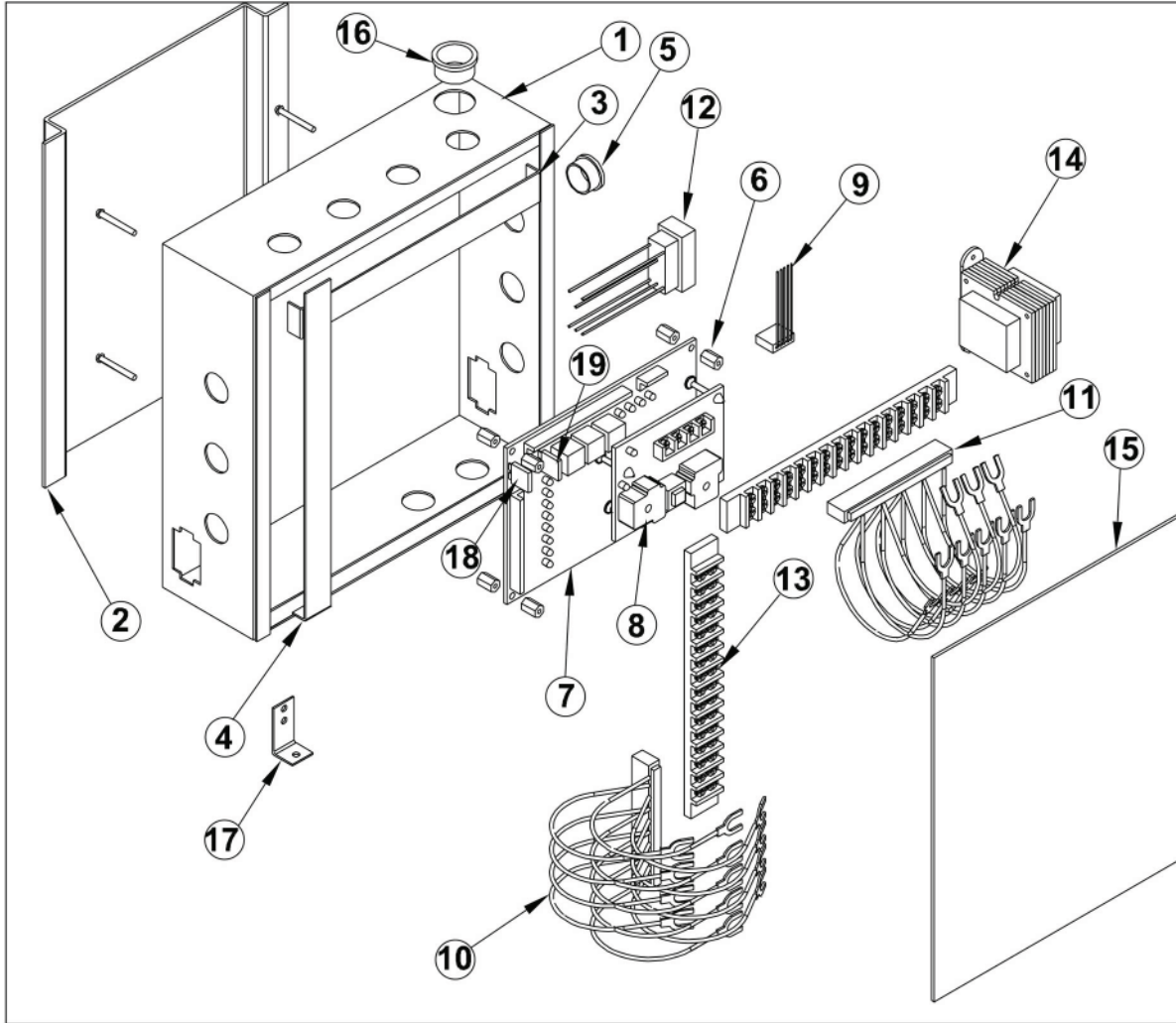

MODEL **GSLG-A** SINGLE PHASE CONTROL BOX PARTS LIST

| REF NO. | PART NO. | DESCRIPTION | REF NO. | PART NO. | DESCRIPTION |
|---------|-----------|-------------------------------------|---------|------------|--------------------------------------------------------------------------------------------|
| 1 | 2100-1778 | Control Box Wrapper | 15 | 2300-696 | Clear Control Box Cover |
| 2 | 2100-1757 | Control Box Mounting Plate | 16 | 2300-735 | Heyco Bushing, 1.09 diameter |
| 3 | 2100-1762 | Terminal Strip Bracket, input side | 17 | 2200-876 | Plunger, spring loaded |
| 4 | 2100-1761 | Terminal Strip Bracket, output side | | 2500-867 | Alarm, 24VAC (not shown) |
| 5 | 2200-122 | Heyco Bushing, .87 diameter | 18 | 2500-1966 | 2 Amp Fuse for Control Board |
| 6 | 2500-1948 | Control Board Standoff | 19 | 2500-1975 | 3 Amp Fuse for Control Board |
| 7 | 2510-268 | Control Board | | 2520-391-D | Complete Controller Assembly 115VAC (order limit harness and mounting brackets separately) |
| 8 | 2500-1946 | AC Motor Drive Board | | 2520-392-D | Complete Controller Assembly 230VAC (order limit harness and mounting brackets separately) |
| 9 | 2510-253 | Control Board with AC Motor Board | | | |
| 10 | 2510-249 | Limit Switch Harness Assembly | | | |
| 11 | 2510-250 | Input Wire Harness Assembly | | | |
| 12 | 2510-261 | Output Wire Harness Assembly | | | |
| 13 | 2500-071 | Control Box Motor Harness Assembly | | | |
| 14 | 2500-212 | Terminal Strip, 16-141 | | | |
| | 2500-791 | Transformer, 115/24VAC, 40VA | | | |
| | | Transformer, 230/24VAC, 40VA | | | |

GSLG-A OPERATOR INSTALLATION GUIDE

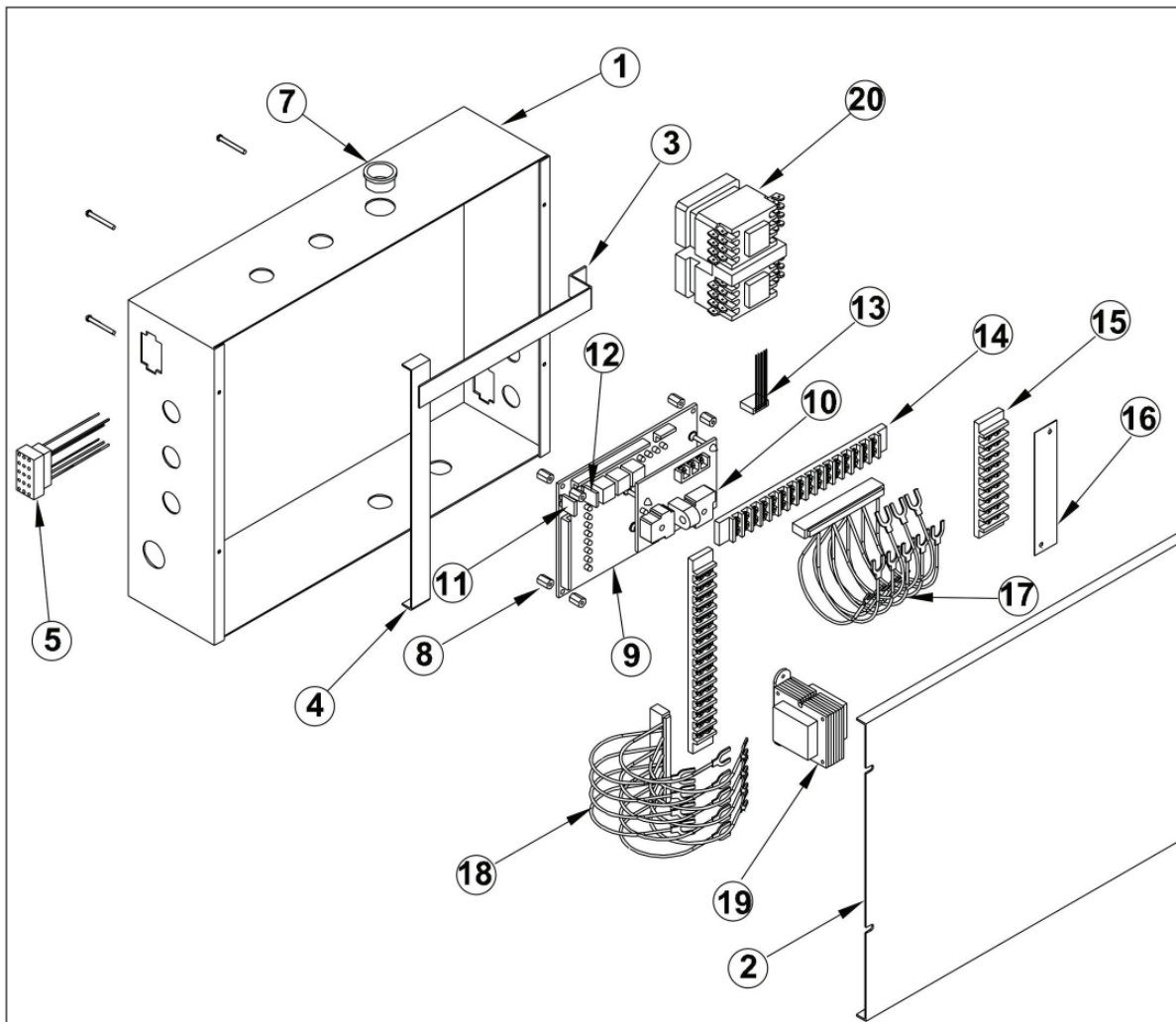

MODEL **GSLG-A** THREE PHASE CONTROL BOX PARTS LIST

| REF NO. | PART NO. | DESCRIPTION | REF NO. | PART NO. | DESCRIPTION |
|---------|-----------|------------------------------------------------------|---------|-----------|--------------------------------------------------------|
| 1 | 2100-1865 | Control Box Wrapper | 14 | 2500-071 | Terminal Strip, 16-141 |
| 2 | 2100-1866 | Control Box Cover | 15 | 2500-270 | Terminal Strip, 9-142 OR |
| 3 | 2100-1864 | Terminal Strip Bracket | | 2500-185 | Terminal Strip, 13-142 |
| 4 | 2100-1762 | Terminal Strip Bracket | 16 | 2300-488 | Terminal Strip Barrier, 9-142 OR |
| 5 | 2510-293 | Control Box Motor Harness Assembly (Leeson motors) | | 2300-885 | Terminal Strip Barrier, 13-142 |
| | 2510-355 | Control Box Motor Harness Assembly (AO Smith motors) | 17 | 2510-250 | Output Wire Harness Assembly |
| 7 | 2300-735 | Heyco Bushing, 1.09 diameter | 18 | 2510-249 | Input Wire Harness Assembly |
| 8 | 2500-1948 | Control Board Standoff | 19 | 2500-767 | 230/24VAC, 75VA, Transformer |
| 9 | 2510-295 | Control Board with 3-Phase Motor Board | | 2500-768 | 460/24VAC, 75VA, Transformer |
| | 2510-268 | Control Board only | 20 | 2500-2084 | Contactor, 24VAC |
| 10 | 2500-1980 | 3-Phase Motor Board | | 2520-400 | Controller, 208/230, 3-Phase |
| 11 | 2500-1966 | 2-Amp Fuse for Control Board | | 2520-401 | Controller, 460, 3-Phase |
| 12 | 2500-1975 | 3-Amp Fuse for Control Board | | | (order limit harness and mounting hardware separately) |
| 13 | 2510-253 | Limit Switch Harness | | | |

Date Prepared: February 02, 1996
Supersedes: January 07, 1995
MSDS Number: 225570

Cette fiche signalétique est aussi disponible en français

1. PRODUCT INFORMATION

Product Identifier: ESSO GEAR OIL GX 80W-90
Application and Use: Premium quality multigrade extreme pressure gear oil for use in automotive applications including some manual transmissions.
Product Description: A lubricating oil consisting of a saturated and unsaturated hydrocarbons derived from paraffinic distillate, and additives.

REGULATORY CLASSIFICATION

WHMIS: Not a controlled product
CEPA: CANADIAN ENVIRONMENTAL PROTECTION ACT
All components of this product are either on the Domestic Substances List (DSL) or are exempt.

TRANSPORTATION OF DANGEROUS GOODS INFORMATION

Shipping Name: Petroleum Lubricating Oil
Class: Not regulated Packing Group: Not regulated
PIN Number: Not regulated Guide Number: 129
Please be aware that other regulations may apply.

TELEPHONE NUMBERS

Emergency 24 hr. 519-339-2145
Technical Info. 800-268-3183

MANUFACTURER/SUPPLIER

IMPERIAL OIL
Products Division
111 St. Clair Ave. West
Toronto, Ontario M5W 1K3
416-968-4111

2. REGULATED COMPONENTS

The following components are defined in accordance with subparagraph 13(a) (I) to (IV) or paragraph 14(a) of the Hazardous Products Act:

| NAME | % | CAS # |
|----------------|---|-------|
| Not applicable | | |

3. TYPICAL PHYSICAL & CHEMICAL PROPERTIES

Physical State: Liquid
Specific gravity: not available
Viscosity: 15.50 cSt at 100 deg. C
Vapour Density: not available
Boiling point: 229 to 600 deg. C
Evaporation rate: <0.1 (1=n-butylacetate)
Solubility in water: negligible
Freezing/Pour Point: -27 deg. C D97
Odour Threshold: not available
Vapour Pressure: <0.1 kPa at 20 deg. C
Density: 0.89 g/cc at 15 deg. C
Appearance/odour: Dark brown liquid, petroleum hydrocarbon odour.

4. HEALTH HAZARD INFORMATION

NATURE OF HAZARD:
INHALATION: Negligible hazard at normal temperatures (up to 38 deg. C). Elevated temperatures or mechanical action may form vapours, mists or fumes which may be irritating to the eyes, nose, throat and lungs. Avoid breathing vapours or mists.
EYE CONTACT: Slightly irritating, but will not injure eye tissue.
SKIN CONTACT: Low toxicity. Frequent or prolonged contact may irritate the skin.
INGESTION: Low toxicity.
ACUTE TOXICITY DATA: Based on animal testing data from similar materials and products, the acute toxicity of this product is expected to be:
Oral: LD50 > 5000 mg/kg (rat)
Dermal: LD50 > 3160 mg/kg (rabbit)
Inhalation: LC50 > 5000 mg/m3 (rat)
OCCUPATIONAL EXPOSURE LIMIT:
ACGIH recommends: For oil mists, 5 mg/m3. Local regulated limits may vary.

5. FIRST AID MEASURES

INHALATION: Vapour pressure of this material is low and as such inhalation under normal conditions is usually not a problem. If overexposed to oil mist, remove from further exposure. Administer artificial respiration if breathing has stopped. Keep at rest. Call for prompt medical attention.
EYE CONTACT: Flush eyes with large amounts of water until irritation subsides. If irritation persists, get medical attention.
SKIN CONTACT: Flush with large amounts of water. Use soap if available. Remove severely contaminated clothing (including shoes) and launder before reuse. If irritation persists, seek medical attention.
INGESTION: If swallowed, DO NOT induce vomiting. Keep at rest. Get prompt medical attention.

6. PREVENTIVE AND CORRECTIVE MEASURES

PERSONAL PROTECTION: The selection of personal protective equipment varies, depending upon conditions of use. In open systems where contact is likely, wear safety goggles, chemical-resistant overalls, and chemically impervious gloves. Where only incidental contact is likely, wear safety glasses with side shields. No other special precautions are necessary provided skin/eye contact is avoided. Where concentrations in air may exceed the occupational exposure limits given in Section 4 and where engineering, work practices or other means of exposure reduction are not adequate, approved respirators may be necessary to prevent overexposure by inhalation.
ENGINEERING CONTROLS: The use of local exhaust ventilation is recommended to control emissions near the source. Laboratory samples should be handled in a fume hood. Provide mechanical ventilation of confined spaces.

HANDLING, STORAGE AND SHIPPING: Keep containers closed. Handle and open containers with care. Store in a cool, well ventilated place away from incompatible materials. Do not handle or store near an open flame, sources of heat, or sources of ignition. Odorous and toxic fumes may form from the decomposition of this product if stored at temperatures in excess of 45 deg. C for extended periods of time or if heat sources in excess of 121 deg. C are used. Empty containers may contain product residue. Do not pressurize cut, heat, or weld empty containers. Do not reuse empty containers without commercial cleaning or reconditioning.

LAND SPILL: Eliminate source of ignition. Keep public away. Prevent additional discharge of material. If possible to do so without hazard. Prevent spills from entering sewers, watercourses or low areas. Contain spilled liquid with sand or earth. Recover by pumping or by using a suitable absorbent. Consult an expert of disposal or recovered material. Ensure disposal in compliance with government requirements and ensure conformity to local disposal regulations. Notify the appropriate authorities immediately. Take all additional action necessary to prevent and remedy the adverse effects of the spill.

WATER SPILL: Remove from surface by skimming or with suitable absorbents. If allowed by local authorities and environmental agencies, sinking and/or suitable dispersants may be used in unconfined waters. Consult an expert on disposal of recovered material. Ensure disposal in compliance with government requirements and ensure conformity to local disposal regulations. Notify the appropriate authorities immediately. Take all additional action necessary to prevent and remedy the adverse effects of the spill.

7. FIRE AND EXPLOSION HAZARD

Flash point and method: 178 deg. C COC D92
Auto ignition: NA Flammable Limits: LEL: NA UEL: NA

GENERAL HAZARDS:

Low hazard; liquids may burn upon heating to temperatures at or above the flash point. Decomposes; flammable/toxic gases will form at elevated temperatures (thermal decomposition). Toxic gases will form upon combustion.

FIRE FIGHTING: Use water spray to cool fire exposed surfaces and to protect personnel. Shut off fuel to fire.

Use foam, dry chemical or water spray to extinguish fire. Respiratory and eye protection required for fire fighting personnel. Avoid spraying water directly into storage containers due to danger of boil over. A self-contained breathing apparatus (SCBA) should be used for all indoor fires and any significant outdoor fires. For small outdoor fires, which may easily be extinguished with a portable fire extinguisher, use of an SCBA may not be required.

HAZARDOUS COMBUSTION PRODUCTS: Smoke, carbon monoxide, carbon dioxide and traces of oxides of sulphur. Alkyl mercaptans and sulfides may also be released.

8. REACTIVITY DATA

STABILITY: This product is stable. Hazardous polymerization will not occur.
INCOMPATIBLE MATERIALS AND CONDITIONS TO AVOID: Strong oxidizing agents.
HAZARDOUS DECOMPOSITION: Smoke, carbon monoxide, carbon dioxide, oxides of sulphur and phosphorus. Alkyl mercaptans and sulfides may also be released.

9. NOTES

This MSDS has been revised in Section 3.

10. PREPARATION

Date Prepared: February 02, 1996
Prepared by: Lubricants & Specialties
IMPERIAL OIL
Products Division
111 St. Clair Ave., West
Toronto, Ontario M5W 1K3
800-268-3183

CAUTION: "The information contained herein relates only to this product or material and may not be valid when used in combination with any other product or material or in any process. If the product is not to be used for a purpose or under conditions which are normal or reasonably foreseeable, this information cannot be relied upon as complete or applicable. For greater certainty, uses other than those described in Section 1 must be reviewed with the supplier. The information contained herein is based on the information available at the indicated date of preparation. This MSDS is for the use of Imperial Oil. Customers and their employees and agents only. Any further distribution of this MSDS by Imperial Oil customer is prohibited without the written consent of Imperial Oil."

IMPERIAL OIL
Products Division

ESSO GEAR OIL GX 80W-90

GSLG-A OPERATOR INSTALLATION GUIDE

PREVENTATIVE MAINTENANCE

IMPORTANT!

- Always disconnect power from operator before servicing.
- Keep clear of gate during operation.

GENERAL:

LINEAR gate operators are designed for many years of trouble-free operation and, under recommended operating conditions, will require only minimal maintenance. To ensure that your unit is ready for operation at all times--and to preclude serious damage or failure--inspect the unit systematically. Proper adjustments and lubrication should be made as recommended.

LUBRICATION:

Bearings. For models which have pillow block style bearings with greaseable fittings, lubricate at least twice a year with a lithium complex based, petroleum oil NLGI 2 rated grease. Oilite and precision sealed bearings do not require additional lubrication.

Motor. Motors have sealed ball bearings and do not require further lubrication. If bearing noise develops after several years of operation, bearings should be replaced by a motor repair company, or the motor should be replaced if necessary.

Drive Chain and Sprocket (slide gate models only). The main drive chain and sprockets should be inspected for wear, cleaned, and wiped down with a lightly oiled rag every six months.

Swing Gate Arm (swing gate models only). Check all bolts for proper tension and tighten if necessary. Make sure the arm folds overextends itself slightly against the overt ravel stop to reduce the chance that the gate can be back driven open. Adjust the close limit slightly if additional travel is required. Lightly lubricate all pivot points with a light machine oil.

Barrier Gate Arm (barrier gate models only). Check all bolts for proper tension and tighten if necessary. If the arm has been warped or damaged, replace as necessary.

ADDITIONAL SIX MONTH PREVENTATIVE MAINTENANCE:

1. For operators which utilize torque limiting clutches, check for proper tightness. If there appears to be dust from wear on the pads, inspect the pads and replace if necessary. If the clutch cannot be adjusted tightly enough to move the gate without slipping, the pads must be replaced.
2. For operators with V-belts, inspect for wear and replace as necessary. Check for proper tension and adjust if required. Check all pulley setscrews for tightness and tighten if necessary.
3. For operators with internal chain drives, inspect chain and sprockets for wear and replace if necessary. Check for proper tension and alignment, and adjust if required. Check all hub sprocket setscrews and tighten if required.
4. Check limit switches and limit actuators (cams, limit nuts, etc.) for wear and replace as required. In rotary limit switch assemblies, wipe the limit shaft clean and apply a light coating of dry lubricant.
5. For operators with magnetic brakes, check for proper adjustment. Brake disc must run free when the brake is engaged. For brake assemblies other than C-face style, the brake should be adjusted so that the solenoid plunger throw is between 3/8" to 1/2". Too much throw will damage the solenoid. **If the solenoid emits a loud buzzing sound when the motor is run, the brake must be adjusted.**
6. In operators which have a disconnect handle, inspect disconnect handle for proper function and lubricate if necessary. Use a lithium based grease on all moving parts.
7. Inspect all nuts and bolts for proper tightness and tighten as necessary.
8. Check all reversing devices for proper function. Inspect all contact edges for wear and replace if required. Check photo-eyes for proper alignment and function.
9. Check current sensing for proper adjustment when finished with inspection and maintenance.
10. Inspect the installation area. Are all the warning signs intact and visible? If they are missing or need replaced, contact LINEAR. Be sure there are no control stations mounted within reach of the gate. Review safety literature with the customer and advise them to remove any such stations found.

For slide and swing gate operators, you must inspect the gate for proper operation. The gate should move easily without binding through its entire travel. If the gate does bind, adjust or fix as required. Failure to keep the gate in good working condition will have adverse effects on the operator.

GSLG-A OPERATOR INSTALLATION GUIDE

This page intentionally left blank.

GSLG-A OPERATOR INSTALLATION GUIDE

GATE OPERATOR INSTALLATION CHECKLIST

| INSTALLER | CUSTOMER | |
|-----------|----------|------------------------------------------------------------------------------------------------------------------------------------------------------------------------------------------------------------------------------------------------------------------------------------------------------------------------------------------------------------------------------------------------------------------------------------------------|
| _____ | _____ | 1. The gate has been checked to make sure it is level and moves freely in both directions. |
| _____ | _____ | 2. Potential pinch areas have been guarded so as to be inaccessible OR have contact and/or non-contact obstruction sensing devices installed. |
| _____ | _____ | 3. The installer has installed one or more contact or non-contact obstruction sensing devices, in compliance with UL325 requirements for this installation. |
| _____ | _____ | 4. The slide gate has been screened or secured from the bottom of the gate to a minimum of 48 inches above ground to prevent a 2 1/4-inch sphere from passing through the openings anywhere in the gate and in that portion of the adjacent fence that the gate covers when the gate is in the open and closed positions. Picket gates which have spacings less than 2 1/4 inches apart to the minimum height requirement are also acceptable. |
| _____ | _____ | 5. Roller covers have been installed on cantilever gates. |
| _____ | _____ | 6. Pedestrians have been supplied with a separate access opening. The customer has been informed that <u>all pedestrian traffic must use the pedestrian gate.</u> |
| _____ | _____ | 7. Two (2) warning signs have been installed, one on each side of the gate in easily visible locations. The customer has been informed that these signs must remain at all times. |
| _____ | _____ | 8. Controls intended for user activation are located at least six feet (6') away from any moving part of the gate and where the user is prevented from reaching over, under, around or through the gate to operate the controls. Outdoor or easily accessible controls have a security feature to prevent unauthorized use. |
| _____ | _____ | 9. The installer has properly adjusted the obstruction sensing feature and has tested the gate to make sure that the gate stops and reverses a short distance with minimal resistance applied (40 lbs. on a swing gate at the end of the gate, 75 lbs. on a slide gate) |
| _____ | _____ | 10. The installer has instructed the customer in the proper use of the gate operator and reviewed all of the operational functions, obstruction sensing devices, warning beeper and reset, etc. |
| _____ | _____ | 11. The installer has instructed the customer in the proper use of the operator's manual disconnect feature. The manual disconnect must never be used while the gate is in motion. The power switch must be turned off before using the manual disconnect and disengaging the operator. |
| _____ | _____ | 12. The installer has reviewed all safety instructions with the customer, and has left the safety instructions and owner's information sheets for their reference. |
| _____ | _____ | 13. The installer has answered any questions the customer has regarding the operation of the gate operator and gate operator safety precautions. |
| _____ | _____ | 14. The installer has explained to the customer that a regular maintenance schedule for both the gate and the gate operator is recommended. |

By signing this installation checklist, I/we hereby certify that each item listed and checked above has been covered by the installer and is clearly understood by the customer.

Customer Signature

Date

Installer Signature

Date