

SWR • SWC • SWD

INSTALLATION GUIDE

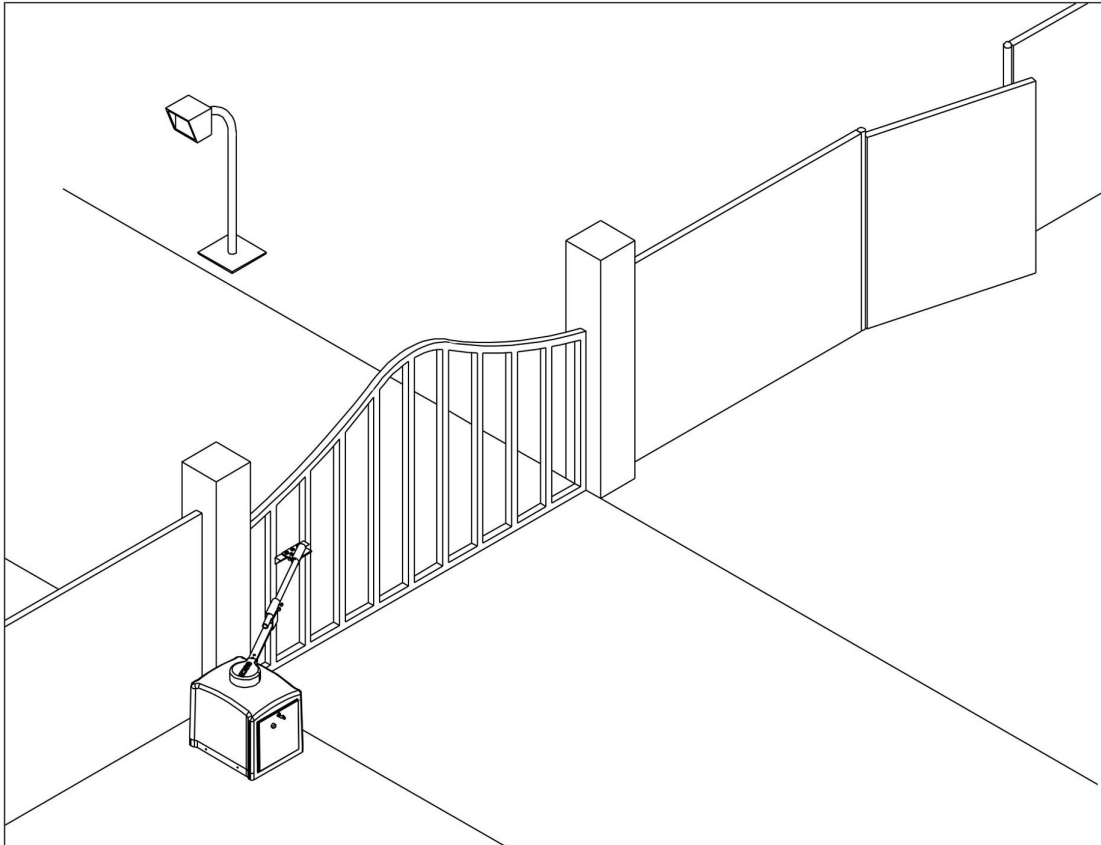

OSCO[®]

OPERATOR SPECIALTY COMPANY, INC.

CASNOVIA, MI 49318 • U.S.A.



**UL325 COMPLIANCE REQUIRES THE USE OF CONTACT EDGES
OR PHOTOELECTRIC CONTROLS ON ALL AUTOMATIC OR
REMOTELY-CONTROLLED GATE OPERATORS.**

SWR • SWC • SWD OPERATOR INSTALLATION GUIDE

TABLE OF CONTENTS

PRE-INSTALLATION INFORMATION	
Gate Operator Classifications	3
Safety Information and Warnings	3
Pre-Installation Information	3
Warranty	3
INSTALLATION	
Wiring Specifications	4
Pad Mounting Instructions	5
String Method for Nonstandard Installation of Swing Gate Operators	6
Articulating-Style Arm Assembly Instructions	7
Vent Plug Installation	8
Torque Limiter Adjustment	8
Electrical Connection and Adjustments	9
Limit Cam Adjustments	9
Control Box Access and Removal	9
CONTROL BOARD ADJUSTMENTS and ACCESSORY CONNECTIONS	
Control Board Adjustments	10
Terminal Connection Descriptions	11
Current Sensing Adjustments	12
Close Direction Current Sense Adjustment	12
Open Direction Current Sense Adjustment	12
Maximum Run Timer Adjustment	12
Auto Close Timer Adjustment	12
Master/Slave Connection	12
Battery Back-Up Charger Board Configuration	12
Onboard L.E.D. Indicator Descriptions	13
Charger Board Sleep Mode	14
Important Notes for Installation of Master/Slave Applications	15
Surge Protector Instructions	15
Control and Accessory Connection Illustrations	16-19
ILLUSTRATIONS	
Loop Layout Illustration	20
Edge Layout Illustration	21
Photo Eye Illustration	22
TROUBLESHOOTING	23
PARTS LISTS	
How to Order Replacement Parts	23
Model SWR Mechanical Parts Exploded View	24
Model SWR Mechanical Parts List	25
Model SWC Mechanical Parts Exploded View	26
Model SWC Mechanical Parts List	27
Model SWR • SWC Control Box Exploded View and Parts List	28
Model SWD Mechanical Parts Exploded View	29
Model SWD Mechanical Parts List	30
Model SWD Control Box Exploded View and Parts List	31
Model SWR • SWC • SWD Gate Arm Assembly Parts List	32
Model SWD Battery Maintenance and Brush Replacement	33
PREVENTATIVE MAINTENANCE	37
GATE OPERATOR INSTALLATION CHECKLIST	38

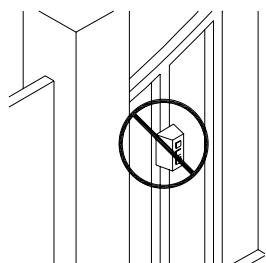

CAUTION!
DO NOT INSTALL
CONTROLS ON OR
NEAR THE GATE

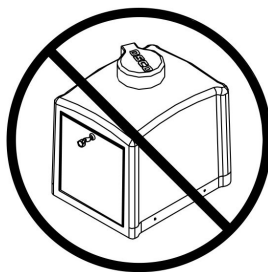

CAUTION!
ONLY QUALIFIED SERVICE
TECHNICIANS SHOULD
WORK ON AN OSCO
SWING GATE OPERATOR

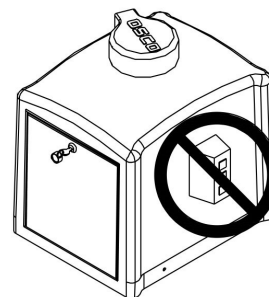

CAUTION!
DO NOT INSTALL
CONTROLS ON
THE OPERATOR

SWR • SWC • SWD OPERATOR INSTALLATION GUIDE

GATE OPERATOR CLASSIFICATIONS

All gate operators can be divided into one of four different classifications, depending on their design and usage.

Class I Residential Vehicular Gate Operator

A vehicular gate operator intended for use in a home of one to four single family dwellings, or garage or parking area associated with these dwellings.

Class II Commercial / General Access Vehicular Gate Operator

A vehicular gate operator intended for use in a commercial location or building such as a multifamily housing unit of five or more single family units, hotel, retail store or other building servicing the general public.

Class III Industrial / Limited Access Vehicular Gate Operator

A vehicular gate operator intended for use in an industrial location or building such as a factory or loading dock area or other location not intended to service the general public.

Class IV Restricted Access Vehicular Gate Operator

A vehicular gate operator intended for use in a guarded industrial location or building such as an airport security area or other restricted access locations not servicing the general public, in which unauthorized access is prevented via supervision by security personnel.

IMPORTANT!!

Before installing the gate operator, make sure the gate's swing is free and level throughout the entire swing path. If the gate does not seem to operate properly, it may affect the operator performance or greatly shorten the life of the unit. The gate should be designed so that airflow is ample to prevent wind resistance and drag.



SAFETY INFORMATION AND WARNINGS

Read the following before beginning to install OSCO swing gate operators:

1. Read the orange "Safety Instructions" brochure enclosed with the packet of information. If you do not have one, please call OSCO at 1-800-333-1717 to request one. Read and follow all instructions.
2. All electrical connections to the power supply must be made by a licensed electrician and must observe all national and local electrical codes.
3. A separate power-disconnect switch should be located near the operator so that primary power can be turned off when necessary.
4. Install the enclosed warning signs on both sides of the gate. Each sign must be plainly visible from the side of the gate on which they are mounted.
5. Never reach between, through or around the fence to operate the gate.
6. You must install all required safety equipment.

PRE-INSTALLATION INFORMATION

Before unpacking, inspect the carton for exterior damage. If you find damage, advise the delivery carrier of a potential claim. Inspect your package carefully. You can check your accessory box parts with the enclosed packing slip for your convenience. Claims for shortages will be honored for only 30 days from the date of shipment.

Before installing the operator, read this manual completely to ensure all requirements for proper installation are present. Verify that the voltage to be used matches the voltage of the operator.

The following contact or non-contact obstruction detection devices have been approved for use with OSCO slide gate operators as part of a UL325 compliant installation:

Contact Edges:

Miller Models*: MG0-20, MGR-20, MGS-20, and ME-120

Photoeyes:

2520-441	MMTC Model IR-55 photoeye, 165' with mounting hardware
2520-031	MMTC Model E3K photoeye, 28' with mounting hardware

**for OSCO part numbers, contact a sales representative for details*

SWR • SWC • SWD OPERATOR INSTALLATION GUIDE

WIRING SPECIFICATIONS

- Select from the chart at the bottom of this page corresponding to the model, voltage and horsepower rating of your operator.
- The distance shown on the chart is measured in feet from the operator to the power source. **DO NOT EXCEED THE MAXIMUM DISTANCE.** These calculations have been based on standard 115V and 230V supplies with a 10% drop allowable. If your supply is under the standard rating, the runs listed may be longer than what your application will handle, and you should not run wire too near the upper end of the chart for the gauge of wire you are using.
- When large-gauge wire is used, a separate junction box (not supplied) may be needed for the operator power connection.
- All control devices are now 24VDC, which can be run considerable distances.
- Wire run calculations are based on the National Electrical Code, Article 430 and have been carefully determined based on motor inrush, brake solenoids, and operator requirements.
- Connect power in accordance with local codes. **The green ground wire must be properly connected.**
- Wire insulation must be suitable to the application.
- Control wiring must be run in a separate conduit from power wiring. Running them together may cause interference and faulty signals in some accessories.
- Electrical outlets are supplied in all 115VAC models for convenience with occasional use or low power consumption devices only. If you choose to run dedicated equipment from these devices, it will decrease the distance for maximum run and the charts will no longer be accurate.
- A three-wire shielded conductor cable is required to connect master and slave operators. You must use Belden 8760 Twisted Pair Shielded Cable (or equivalent) **only** – OSCO part number 2500-1982, per foot). See page 10 for details of this connection, as well as dip switch selection. **Note: The SHIELD wire should be connected in both the master and slave operators.**

USE COPPER WIRE ONLY!

MODEL SWR

Power Wiring			
Volts & HP	Max Distance		Wire Gauge
	Single	Dual	
115V	316	158	12
	502	251	10
	800	400	8
1/2 HP	1272	636	6
	2022	1011	4
230V	764	382	12
	1218	609	10
1/2 HP	1936	968	8
	3076	1538	6
	4896	2448	4

MODEL SWC

Power Wiring											
Volts & HP	Max Distance		Wire Gauge	Volts & HP	Max Distance		Wire Gauge	Volts & HP	Max Distance		Wire Gauge
	Single	Dual			Single	Dual			Single	Dual	
115V	222	111	12	208V	760	380	12	230V	894	447	12
	354	177	10		1200	600	10		1422	711	10
	566	283	8		1924	962	8		2264	1132	8
1/2 HP	900	450	6	1/2 HP	3060	1830	6	1/2 HP	3600	1800	6
	1430	715	4		4864	2432	4		5724	2862	4
115V	178	89	12	208V	604	302	12	230V	710	355	12
	282	141	10		958	478	10		1128	564	10
	450	225	8		1526	763	8		1796	898	8
3/4 HP	716	358	6	3/4 HP	2424	1212	6	3/4 HP	2852	1426	6
	1140	570	4		3856	1928	4		4538	2269	4
115V	160	80	12	208V	544	272	12	230V	640	320	12
	254	127	10		864	432	10		1016	508	10
	406	203	8		1374	686	8		1616	808	8
	646	323	6		2184	1092	6		2570	1285	6
	1026	513	4		3476	1738	4		4090	2045	4

MODEL SWR SWC ACCESSORY WIRING

All Models		
Volts	Maximum Distance (ft.)	Wire Gauge
24VAC	250	14
	350*	12
24VDC	0-2000	14

*Over 350 ft. use DC power.

MODEL SWD

Power Wiring			
Volts & HP	Max Distance		Wire Gauge
	Single	Dual	
115V	970	485	12
	1542	771	10
	2452	1226	8
1/2 HP	3898	1949	6
	6200	3100	4

MODEL SWD ACCESSORY WIRING

All DC Models		
Volts	Maximum Distance (ft.)	Wire Gauge
24VDC	0-2000	14

*Over 350 ft. use DC power.

SWR • SWC • SWD OPERATOR INSTALLATION GUIDE

PAD MOUNTING INSTRUCTIONS

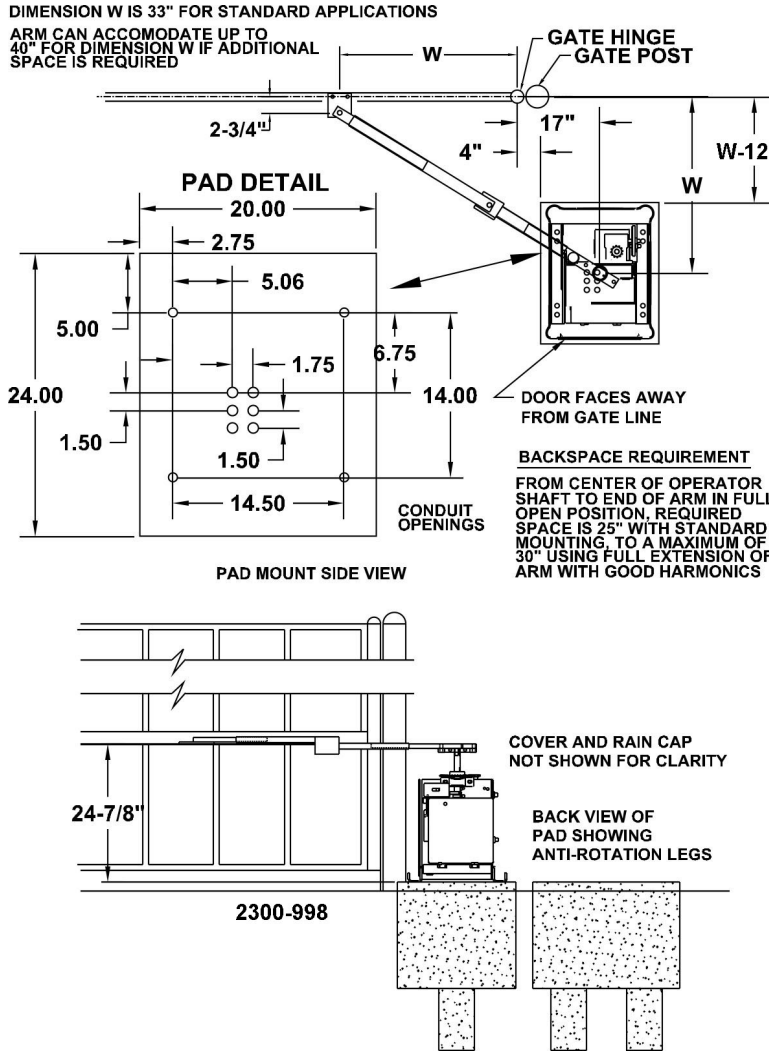

NOTE: Maximum gate opening angle is approximately 95 degrees, depending on gate width. If larger opening angle is required, non-standard positioning of the operator and modified articulating arms will be required. Contact the factory for pricing and availability.

PAD MOUNTING INSTRUCTIONS

Recommended pad size is 24"x20"x18" deep minimum. Pad depth should be set according to local codes and at least as deep as frost line. If soil conditions may cause operator and pad to shift during operation, anti-rotation legs may be required. Use two 6" diameter, 10" deep legs to counteract this problem as shown. 5/8" J-bolts may be set into the concrete before it sets following the dimensions shown, or drilled after the concrete sets.

A large, 2 inch diameter hole has been supplied for conduit placement. Use of flexible conduit will make it easier to line up with this opening.

Assemble the arm components as shown on page 7.

A SEPARATE PEDESTRIAN GATE IS REQUIRED FOR ALL PEDESTRIAN TRAFFIC. THIS GATE MUST BE A MINIMUM DISTANCE OF 7 FEET FROM THE VEHICULAR GATE AND GATE OPERATOR

SWR • SWC • SWD OPERATOR INSTALLATION GUIDE

STRING METHOD FOR NONSTANDARD INSTALLATION OF SWING GATE OPERATORS

Step A: Position the Operator

1. Connect the gate plate assembly onto the gate at the recommended location for a standard installation (Dimension "W").
2. Open the gate to its fully-open position.
3. Position the operator parallel to the gate. The distance from the operator output shaft to the gate plate pivot point is shown at right. The operator should be positioned the same distance from the gate hinge as the gate plate has been; ie: the "W" dimension.

Step B: Measure the Crank Extension and Link Center to Center Distances

1. Close the gate.
2. Using a piece of tape, attach a string to the top of the operator output shaft, at its center. Holding the string taut and using another piece of tape, hold the other end of the string across the hole in the gate plate. This distance is Dimension 1. Carefully measure this dimension and write it down.
3. Open the gate.
4. Pick up the string, while it is still attached at both ends, and pull it taut again while positioning it directly over the center of the operator shaft, at Point "B," and work your way back along the string until you reach Point "C."
5. While holding the string taut, measure the distance from Point "B" to Point "C." This is the required center to center distance for the crank extension.
6. Measure the distance from Point "A" to Point "C." This is the required center to center distance for the link section.
7. When added together, the distances from Point "A" to Point "B" and Point "B" to Point "C" should equal the Dimension 1 measurement.

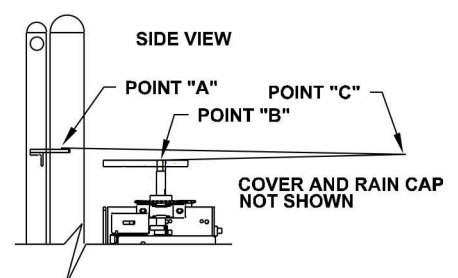
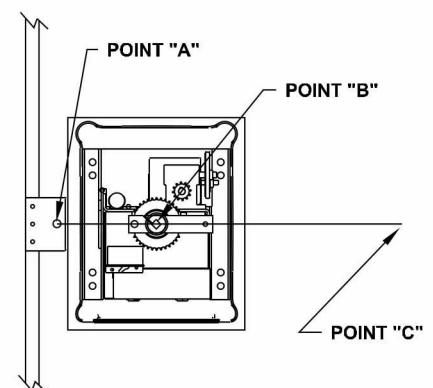
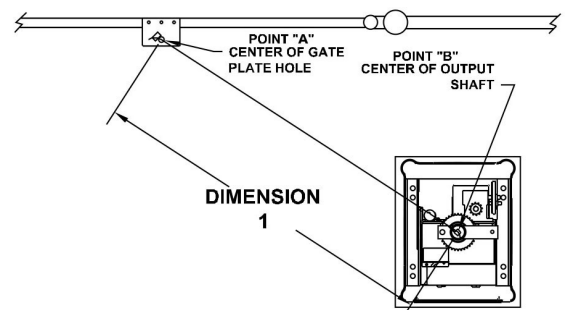
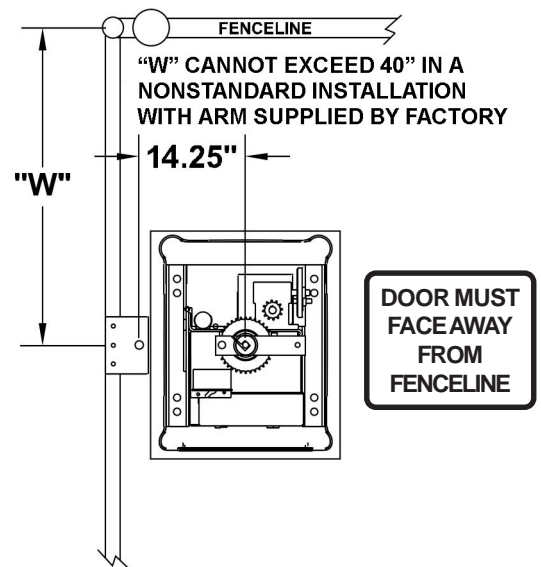

These measurements will be needed when placing an order for special length crank extensions and links. Also note that the measurements you have just calculated are center to center only, and are not overall dimensions, which would also include other attachment hardware, such as gate arm clamps.

It is also possible that both open and closed limit switches may be activated at either end of gate travel due to the total gate travel required, and the shape of the limit switches and cams. This problem can be corrected by carefully bending the limit switch arm slightly and readjusting its cam.

PLEASE NOTE: Your operator may look different when installed. The drawings on this page are for general reference only.

SWR • SWC • SWD OPERATOR INSTALLATION GUIDE

WELDED STYLE GATE ARM INSTALLATION INSTRUCTIONS

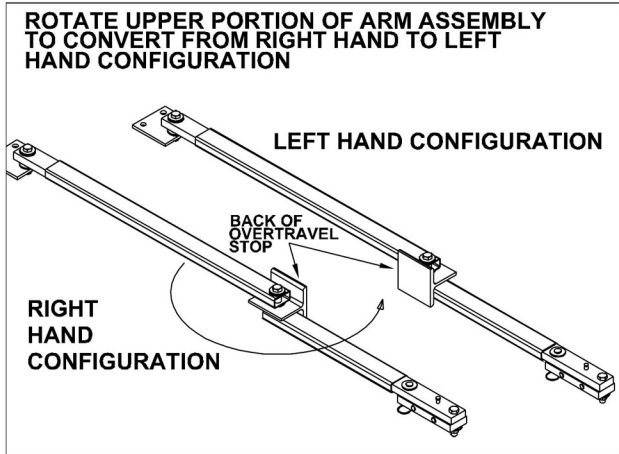

The welded style gate arm has been pre-assembled at the factory in right-hand configuration (the back of the overtravel stop faces toward the drive when the gate is fully closed and the arm is installed). For a left-hand operator, rotate the upper portion of the arm as shown above to convert the arm into a left-hand orientation.

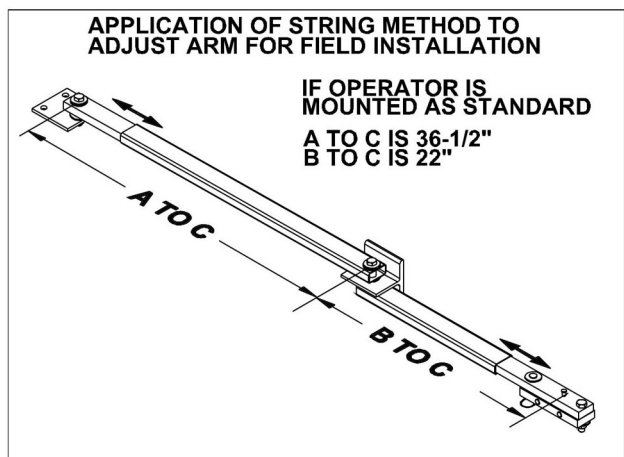

If the operator is mounted using the standard dimensions specified in the installation manual, the dimensions above can be used to adjust and set the arm. If non-standard mounting is required, utilize the string method from the operator manual to determine the A to C and B to C lengths required.

Once these lengths have been determined, use clamps to temporarily attach the solid bars to their sections of rectangular tubing. If clamps are unavailable, you may also tack weld the parts in place. It is recommended that you check the arm for proper action and full gate travel before fully welding the parts together. Apply Krylon metallic gold spray paint or equivalent to touch up weldments when finished.

Good harmonics are necessary to minimize wear and tear on the operator. The illustration at right shows an example of an improperly adjusted arm and one that has been properly installed.

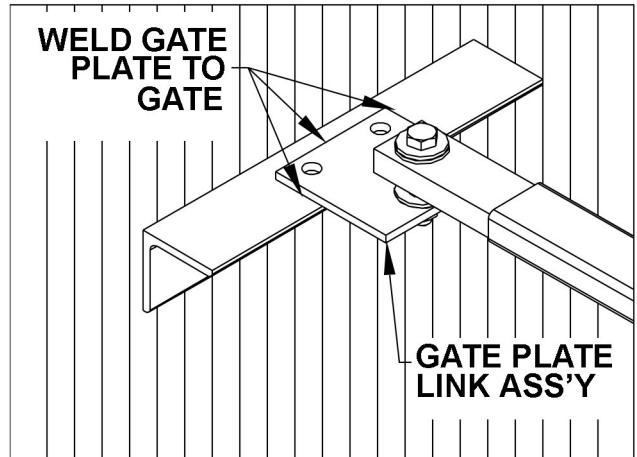

The gate plate supplied with the arm assembly can be welded to the gate as shown above. Holes have been provided for securing the gate plate to an aluminum gate.

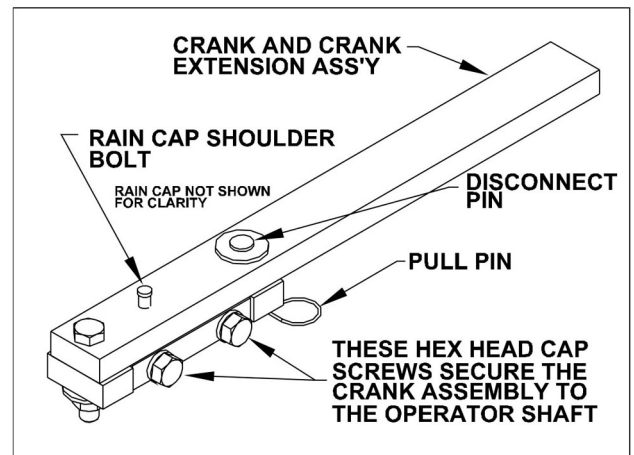

The hex cap screws in the side of the crank assembly are shipped loose for placement on the operator drive shaft. Once in place, tighten these cap screws in place by applying 75 ft•lbs of torque. If it becomes necessary to remove the crank, you can do so by loosening these bolts. The arm can also be disconnected for manual operation of the gate by removing the disconnect pin.

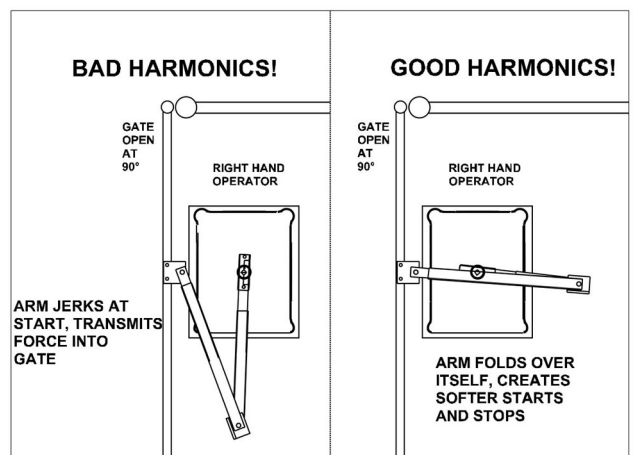

SWR • SWC • SWD OPERATOR INSTALLATION GUIDE

VENT PLUG INSTALLATION

Gear reducers used in OSCO gate operators will have solid plugs installed prior to shipment in order to keep the oil inside from spilling out during shipping. A vent plug has been provided to replace this plug during installation. This plug will look similar to the ones shown below. Some models may have a vent plug with a breather pin. This pin should be removed after installing the operator.

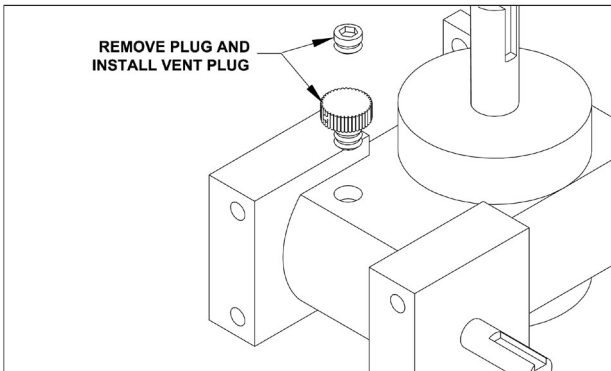

OR

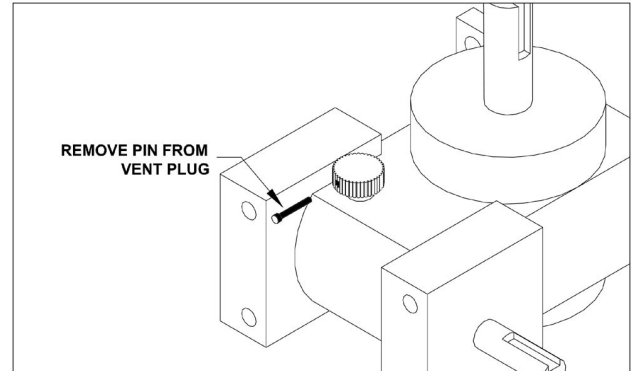

TORQUE LIMITER ADJUSTMENT

This operator may be supplied with an optional torque limiter. Before adjusting the torque limiter, make sure the gate is in good working condition. One person should be able to move the gate by hand. Be certain the gate moves freely and without binding throughout its travel. Torque limiters are set light at the factory. They must be adjusted during installation, preferably after limit cams have been manually set (see page 9). Adjust the torque limiter tight enough to keep it from slipping during normal operation.

To adjust the torque limiter in models SWR and SWD:

1. Bend the locking tabs away from the adjustment nut.
2. *To increase the output*, turn the adjustment nut clockwise one flat, or 1/6 turn, at a time until desired output is obtained.
To reduce the output, turn the adjustment nut counterclockwise one flat, or 1/6 turn, at a time until desired output is obtained.
3. Bend the locking tabs up to lock the adjustment nut in place.

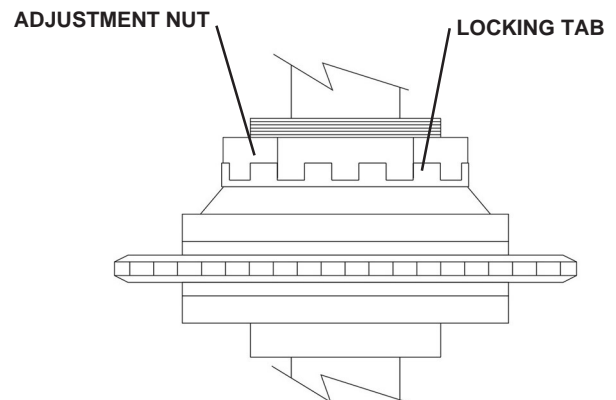

SWR • SWC • SWD OPERATOR INSTALLATION GUIDE

ELECTRICAL CONNECTION AND ADJUSTMENTS



Power supply must be of correct voltage and phase.
Always disconnect power from operator before servicing.
Keep clear of gate during operation.

All OSCO gate operators are supplied with a power disconnect switch to turn on and off the power supply available to the operator. Incoming power should be brought into the operator and connected to the labeled pigtails in the disconnect box, following wiring specifications on page 4. A wiring connections print can be found on the inside cover of the operator.

Proper thermal protection is supplied with the operator. The motor contains a thermal overload protector to protect from overheating the motor due to overload or high-frequency operation. This overload will reset automatically after the motor cools down.

LIMIT CAM ADJUSTMENTS

The limit cams are not preset at the factory and must be adjusted for the length and opening angle of the gate the operator is installed on. The limit switches are activated by a series of rotating limit cams which are attached to the drive shaft. The operator has also been preset in the right hand operation mode. If the installation requires left hand operation a dip switch must be flipped (see page 10).

With the gate connected to the gate operator in a mid-travel position, the power disconnect switch turned **OFF**, and the torque limiter set loose enough to slip freely, manually move the gate to its fully open position.

Once the gate is in the fully open position, adjust the limit cam for open direction. Set the **LSO-1** limit cam so that it has just triggered its switch.

Once the open limit cam is set, repeat the above process for the close direction, **LSC-1**.

After finishing the initial limit cam adjustments, reposition the gate to approximately the center of travel. At this time, adjust the torque limiter as explained on page 8. Turn the power disconnect switch **ON**, stand clear of any moving parts and press the **OPEN** button. Observe the gate as it runs through a complete cycle in both directions, and adjust your limits again if necessary. If the operator stops during travel, you may need to adjust the open or close current sensor adjustment or the maximum run timer (see page 12).

POWER DISCONNECT BOX
(115VAC SWR VERSION SHOWN)

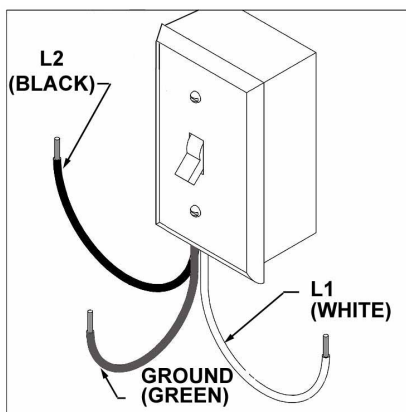

LIMITS and CAMS
MODEL SWR, SWC and SWD

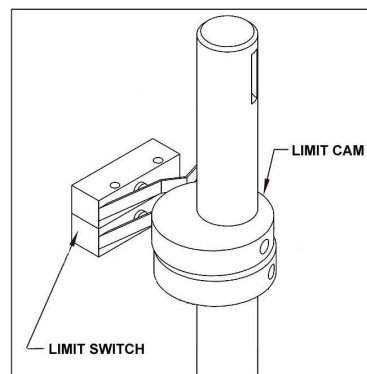

FROM TOP TO BOTTOM:
LEFT HAND RIGHT HAND
LSC-1 LSO-1
LSO-1 LSC-1

WHENEVER HAND OF OPERATION CHANGES,
BOTH LIMIT CAMS WILL NEED TO BE ADJUSTED.

CONTROL BOX ACCESS AND REMOVAL

The control box in models SWR, SWC and SWD is hinged for flip-down access and can be removed without taking off the operator cover. Start by pulling down the plunger located on the left side of the control box. While holding the plunger down, slide the control box to the right until the hinges have come apart. Once freed, you can turn the control box slightly and remove it from the operator. Be careful not to pull on the cables that connect to the control box.

Under most circumstances you will not need to remove the control box. By pulling the plunger and swinging the control box down, you can gain access for installation and troubleshooting.

SWR • SWC • SWD OPERATOR INSTALLATION GUIDE

CONTROL BOARD ADJUSTMENTS

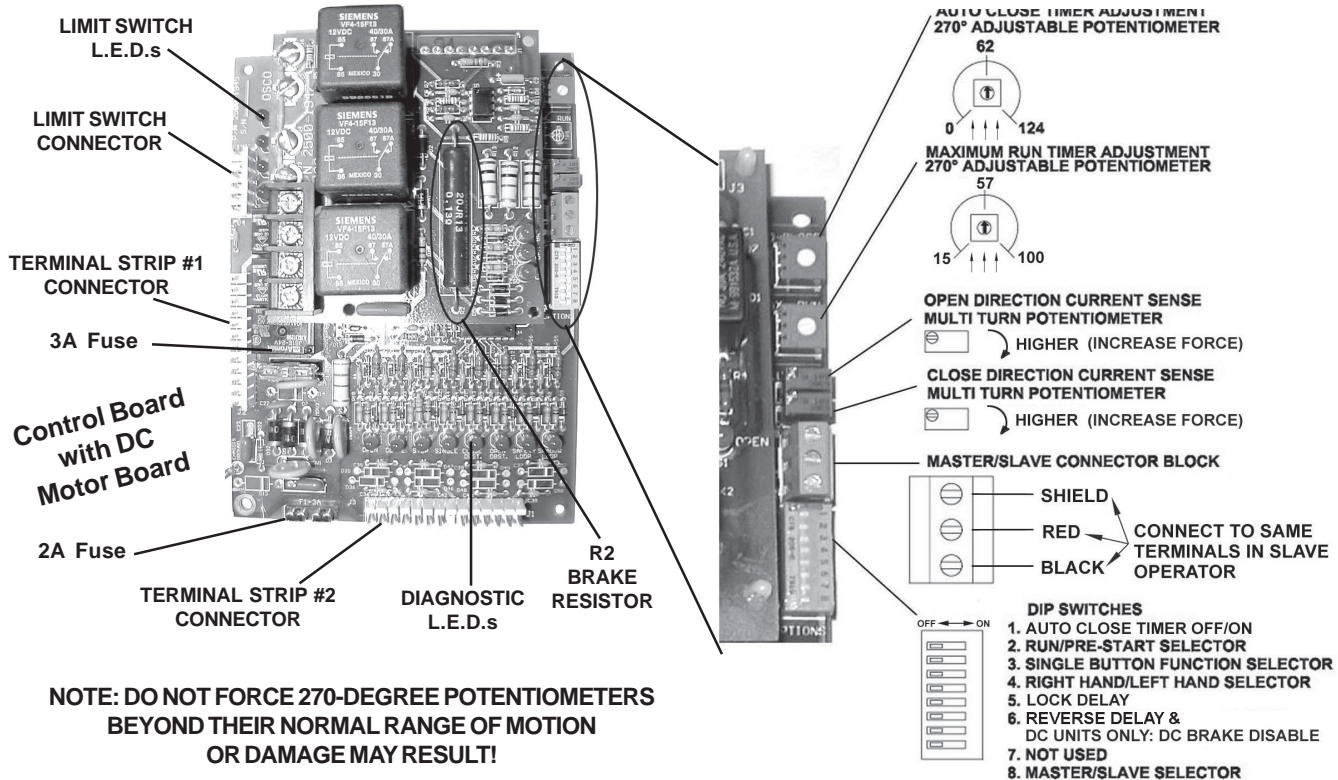

Auto Close Timer Adjustment: This 270-degree adjustable potentiometer will signal the operator to close automatically, provided no open, reversing or obstruction signals are present from the fully-open position. This timer is adjustable from 0 to 124 seconds. This feature is turned on or off using dip switch #1.

Maximum Run Timer Adjustment: This 270-degree adjustable potentiometer will signal the operator to stop running once it counts down, unless a limit switch is reached or an input is received first. Each time the motor starts, this timer will begin counting. This timer is adjustable from 15 to 100 seconds. If the timer expires, the unit locks out and the emergency alarm sounds.

Open Direction Current Sense Adjustment: This multiturn potentiometer is used to calibrate the built-in current sensing feature for detection of obstructions while running in the open direction.

Close Direction Current Sense Adjustment: This multiturn potentiometer is used to calibrate the built in current sensing feature for detection of obstructions while running in the closed direction.

Master/Slave Connection Block: This terminal block is used in conjunction with two operators to configure two gates to open and close together.

Dip Switches:

- #1 This switch turns the auto close timer off/on.
- #2 This switch is used in conjunction with alarms and flashing lights that may be added to the operator. When the switch is in the **ON** position, these devices will start approximately two seconds prior to the operator starting. In the **OFF** position, the devices will only work while the operator is running.
- #3 This switch is used in conjunction with single-button controls and radio receivers. In the **ON** position, successive inputs will cause signals in the order of **OPEN-STOP-CLOSE-STOP**. In the **OFF** position, inputs will cause an **OPEN** signal unless the gate is fully open, in which case it will signal **CLOSE**.
- #4 This switch determines right-hand vs. left-hand behavior. When looking from inside the protected area toward the gate, the side of the drive the operator is on determines its hand of operation. In the **OFF** position, the operator is set for right-hand.
- #5 When turned **ON**, this switch will allow a one-second delay for solenoid locks to unlock before the motor starts.
- #6 In the **ON** position, the reverse delay is three seconds. In DC operators only, this also disables the inherent DC brake (provided the R2 brake resistor is cut, see picture above). In the **OFF** position, the reverse delay is 1 1/2 seconds and the DC inherent brake is enabled.
- #7 Not used at this time.
- #8 This switch is used to set Master/Slave configuration. Operators which are stand-alone or master units should be set to **OFF**, while only slave units should have this switch set to **ON**.

SWR • SWC • SWD OPERATOR INSTALLATION GUIDE

TERMINAL CONNECTION DESCRIPTIONS

TERMINALS	FUNCTION	DESCRIPTION OF FUNCTION
24VAC 24VAC N	24VAC	Provides fused 24Volt AC power for accessories. Note: DC models will NOT have 24Volt AC power available.
24VDC+ 24VDC- COMM.	24VDC	Provides fused 24Volt DC power for accessories.
1 & 4	OPEN	Opens the operator. Several accessories such as button stations, keypads, transmitters and card readers can be wired to open.
3 & 4	CLOSE	Closes the operator. Use caution when wiring accessories to these terminals. The gate must be clearly visible from the location of any accessories wired to close.
4 & 5	SINGLE-BUTTON	Performs the single-button function which will alternate between open and close or open, stop and close - depending on dip switch #3. (See page 10 for details.)
2 & 4	STOP	Stops the operator. If no stop button is used, a jumper is required across 2&4 .
4 & 6	REVERSE	This function will cause a reversal when the gate is traveling closed and will travel back to the fully open position. Loop detectors are often wired for reverse.
4 & 50	OPEN OBSTRUCTION	This function works only while the operator is opening. Any signal to this function will cause the gate to stop, reverse a short distance, and then stop again. At this time the auto close timer is disabled, and a renewed input will be required to start the gate again. Should the gate be restarted and the signal occur again prior to reaching a limit, the gate will stop again, and this time will sound the emergency alarm and lock out.
4 & 51	CLOSE OBSTRUCTION	This function works exactly like the OPEN OBSTRUCTION, except that it will only work in the closing direction.
4 & 11	SHADOW/HOLD	This function will keep the gate in its fully open position while the signal is present. This is typically used with a loop and loop detector to keep a large swing gate open while vehicular traffic is passing through.
24VDC+ & 60	RUN/PRE-START	A 24Volt DC device such as a strobe light or alarm can be wired to these terminals. Depending on dip switch #2, these devices will either begin three seconds before the operator starts, or only while the motor is running. (See page 10 for details.)

 You must follow all required safety precautions and instructions at all times. Review the safety brochure included with the operator. If any pages are missing or unreadable, contact OSCO at 1-800-333-1717 to request additional copies.

 Never connect a button station within reach of the gate or on the side of the gate operator.

 Do not adjust the circuit board current sensing feature too high. It should be adjusted high enough to keep the gate from falsely triggering the sensing, but no higher than necessary for the gate to operate. Do not defeat the purpose of this function!

SWR • SWC • SWD OPERATOR INSTALLATION GUIDE

CURRENT SENSING ADJUSTMENTS

Because gates vary in construction and may have different force requirements in the open and close directions to move, the OSCO control board has separate Multi-turn potentiometers for adjusting in both directions independently. The adjustment should be set light enough to maintain minimal force (40 lbs.) should an obstruction occur, but high enough to keep the gate moving under normal conditions without interruption.

Prior to adjusting the operator current sensing functions, make sure the gate moves freely in both directions. A badly aligned or poorly maintained gate may cause false triggering of the current sensor. Refer to page 10 when following the instructions below. A factory adjustment tool has been supplied to make these adjustments easier. This tool has been taped to the control box for your convenience.

CLOSE DIRECTION CURRENT SENSE ADJUSTMENT

When the gate operator leaves the factory, it has been preset for a relatively light gate function and will require additional adjustment. Begin by starting the gate going closed. If the operator stops and reverses, turn the close direction potentiometer (see page 10) one turn higher, press the **STOP** button, and try again. Repeat this process until the gate no longer causes false tripping of the current sensor. Note that each time the gate operator reverses, the **STOP** button must be pressed. Next, turn the close direction potentiometer lower slowly while the operator is running the gate closed until the gate operator stops and reverses again. From this point, turn the close direction potentiometer higher by 1 1/2 turns for all 115 Volt AC and 24 Volt DC operators, and by 3/4 of a turn higher for all 230 Volt AC operators. Additional fine adjustment by 1/4 turns may be necessary to eliminate false triggering.

OPEN DIRECTION CURRENT SENSE ADJUSTMENT

Repeat the same process with the open direction potentiometer while running the gate in the open direction. Once this is done, run the gate through several complete cycles and make sure the gate does not false trip in either direction.

Multi-turn Potentiometer



Remember it is important not to set the adjustment too high! Doing so will defeat the purpose of the current sensing as an obstruction detecting feature.

MAXIMUM RUN TIMER ADJUSTMENT

This adjustable potentiometer sets the maximum length of time the motor will run before shutting down. It should be configured for the time it takes to run the gate fully open or closed, plus an additional 15 seconds. See page 10 for details.

AUTO CLOSE TIMER ADJUSTMENT

This adjustable potentiometer sets the length of time which elapses before the gate operator automatically closes the gate, from the fully open position, provided no open, reversing, or obstruction signals are present. This feature can be turned on or off via dip switch selection. See page 10 for details. **Do not use the auto close timer without an appropriate reversing device installed!**

MASTER/SLAVE CONNECTION

A three-wire shielded conductor cable is required to connect master and slave operators. You must use Belden 8760 Twisted Pair Shielded Cable (or equivalent) **only** – OSCO part number 2500-1982, per foot). See page 10 for details of this connection, as well as dip switch selection. Note: The SHIELD wire should be connected in both the master and slave operators. **In addition, you must run power to both the master and slave operators.**

BATTERY BACK-UP FOR DC MODELS ONLY

CHARGER BOARD CONFIGURATION

To set the voltage monitor, see the picture below. The **RUN** position will monitor the voltage of the battery only after AC voltage has been interrupted. It will allow the operator to continue to function until the batteries have dropped to 17 volts. When the batteries have reached 17 volts, the operator will open and shut down until AC power has been restored. In the **OPEN ONLY** position when AC power has been interrupted the operator will open and shut down until AC power is restored.

Note: If the charger board is set to open only, removing incoming power will cause the operator to run to full open position. Turn off power switch in operator before removing incoming power!

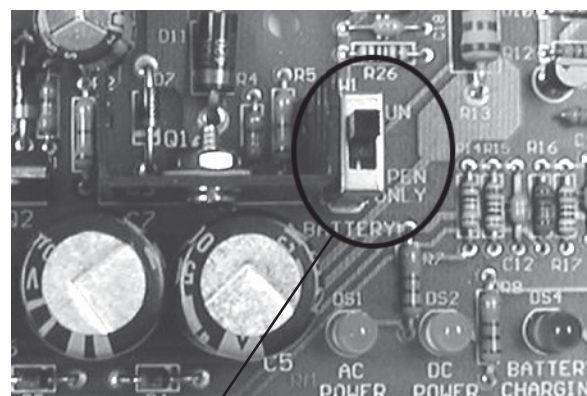

VOLTAGE MONITOR SHOWN ABOVE IN THE RUN POSITION

SWR • SWC • SWD OPERATOR INSTALLATION GUIDE

ONBOARD L.E.D. INDICATOR DESCRIPTIONS

Control Board L.E.D. Indicators:

OPEN	This indicator is lit when an open signal is present. This signal can come from such devices as button stations, radio receivers, keypads and telephone entry systems.
CLOSE	This indicator is lit when a closed signal is present. This signal typically comes from three-button stations.
STOP	This indicator is lit when there is a break in the stop circuit. Make sure there is a stop button wired in and working properly.
SINGLE	This indicator is lit when a signal from a single-button station or radio receiver is present.
CLOSE OBST	This indicator is lit when a close obstruction signal is present. This signal can come from edges and photo eyes which have been wired to the close obstruction inputs.
OPEN OBST	This indicator is lit when an open obstruction signal is present. This signal can come from edges and photo eyes which have been wired to the open obstruction inputs.
SAFETY LOOP	This indicator is lit when a reversing signal is present. This signal is generated by a loop detector wired to the safety loop terminals.
SHADOW LOOP	This indicator is lit when a shadow/hold open signal is present. This signal is generated by a loop detector wired to the shadow loop terminals.
LH RH	
LSC-1 LSO-1	This indicator is lit when the open #1 limit switch is activated on a right-hand operator, or the close #1 switch on a left-hand. If this indicator is lit and the gate is not in its full open/closed position, the limit may need adjusting or the limit switch may need replacing.
LSC-2 LSO-2	This indicator is lit when the open #2 limit switch is activated on a right-hand operator, or the close #2 switch on a left-hand.
LSO-1 LSC-1	This indicator is lit when the close #1 limit switch is activated on a right-hand operator, or the open #1 on a left-hand. If this indicator is lit and the gate is not in its full open/closed position, the limit may need adjusting or the limit switch may need replacing.
LSO-2 LSC-2	This indicator is lit when the close #2 limit switch is activated on a right-hand operator, or the open #2 switch on a left-hand.

Motor Board L.E.D. Indicators:

NON LABELED	One of these two indicators will be lit when the motor is running the gate open, and the other is lit when the motor is running the gate closed.
BRAKE REL.	This indicator is lit when the brake is NOT applied.

DC Operators Only:

AC POWER	Indicates AC power is supplying the unit.
DC POWER	Indicates the operator is running on batteries.
BATTERY CHARGING	Indicates batteries are being charged. Light goes out when batteries reach 90% of full charge.
OPEN GATE	Operator is in open then lockout stage.
POWER LOCKOUT	Flashes when controls/motor are in lockout mode.

SWR • SWC • SWD OPERATOR INSTALLATION GUIDE

CHARGER BOARD SLEEP MODE

When primary AC power is not available, the operator will continue to operate in battery only mode if the charger board is set in its RUN mode (**see Battery Backup Charger Configuration**). Accessories wired into the operator will continue to draw power, even when the operator is not opening or closing the gate. This can dramatically reduce the amount of standby time available from the batteries.

To extend the available standby time, the charger board has a “**sleep**” mode feature which will turn off power to all controls except for any that are wired according to the schematics below. By removing the black jumper cap **JP1** located in the upper right hand corner of the charger board this feature can be enabled. After fifteen minutes of inactivity, all controls except those wired as shown below will turn off. Those wired as shown will continue to have power at all times and will upon activation generate first a “wake” signal that will power all controls back up, and then create either an open signal or single button signal, depending on how the wire jumper shown below is connected.

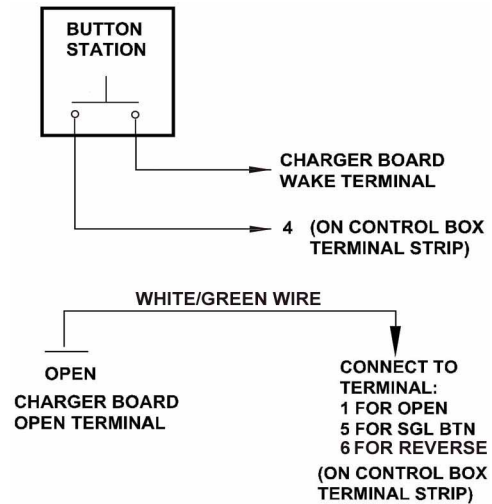
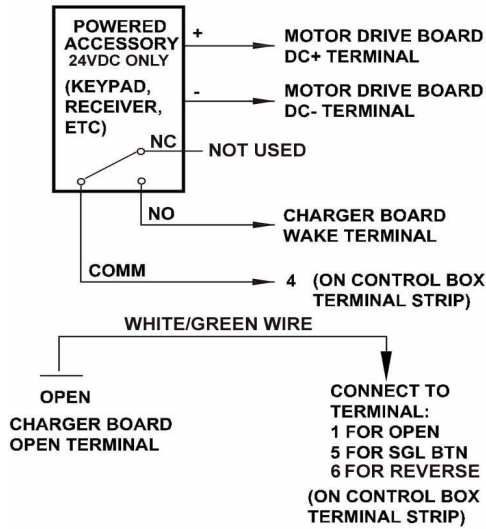
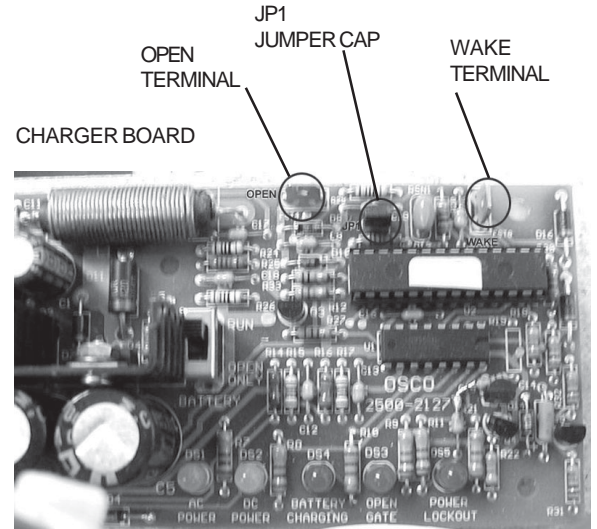

SWR • SWC • SWD OPERATOR INSTALLATION GUIDE

IMPORTANT NOTES FOR INSTALLATION OF MASTER/SLAVE APPLICATIONS

When setting up Master/Slave gate operators, it is best to make adjustments and run each operator individually. To do this, simply:

- Set Dip Switch #4 to proper hand of operation (right-hand or left-hand)
- Set Dip Switch #8 as Master (off)

Run each operator making current sensing adjustments as necessary, as indicated on the Control Board Adjustments page of this installation guide. When both operators have been adjusted, turn power off, then turn on Dip Switch #8 in the operator chosen as the Slave.

The timer to close and radio/single button behavior are set in the Master operator.

The following selections are set individually:

- Current Sensing
- Maximum Run Timer
- One-Second Lock Release
- Three-Second Pre-Start Warning
- Right/Left-Hand Selections

SURGE PROTECTOR INSTRUCTIONS

The optional surge protector should be connected to any inputs that have an accessory connected to it. This includes the 3-button station, so it must be connected to 1, 2A and 3 in all cases. The green wire connected to ground, which is electrically the same as terminal 4. The red wires connect to terminals 2A and 24VDC+. This will cause the 2 amp fuse to blow if this section of the module becomes shorted. With any of the other inputs connected to the surge protector, if their protection line becomes shorted due to a surge over the rating of the module, the corresponding LED on the main board will remain lit, causing a constant signal to the controller. If this is found, please replace the entire surge protector with a new unit.

Do not simply unhook the shorted wire, as this removes the protection from the circuit that was saved by the protector in the first place!

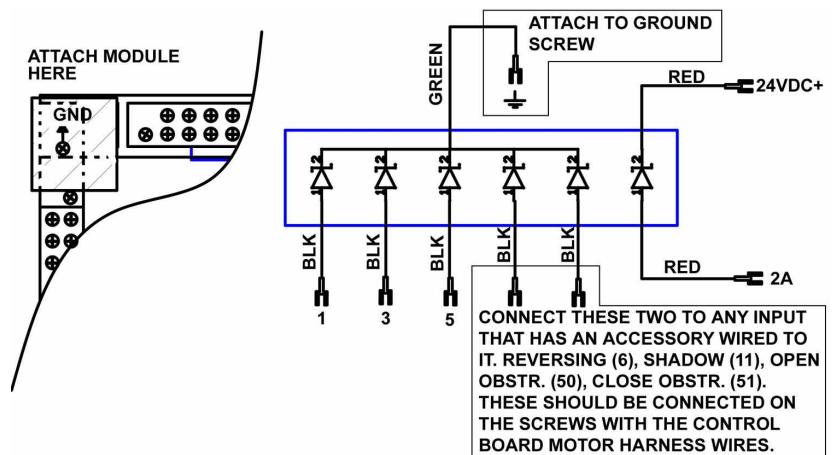

SWR • SWC • SWD OPERATOR INSTALLATION GUIDE

CONTROL and ACCESSORY CONNECTION ILLUSTRATIONS

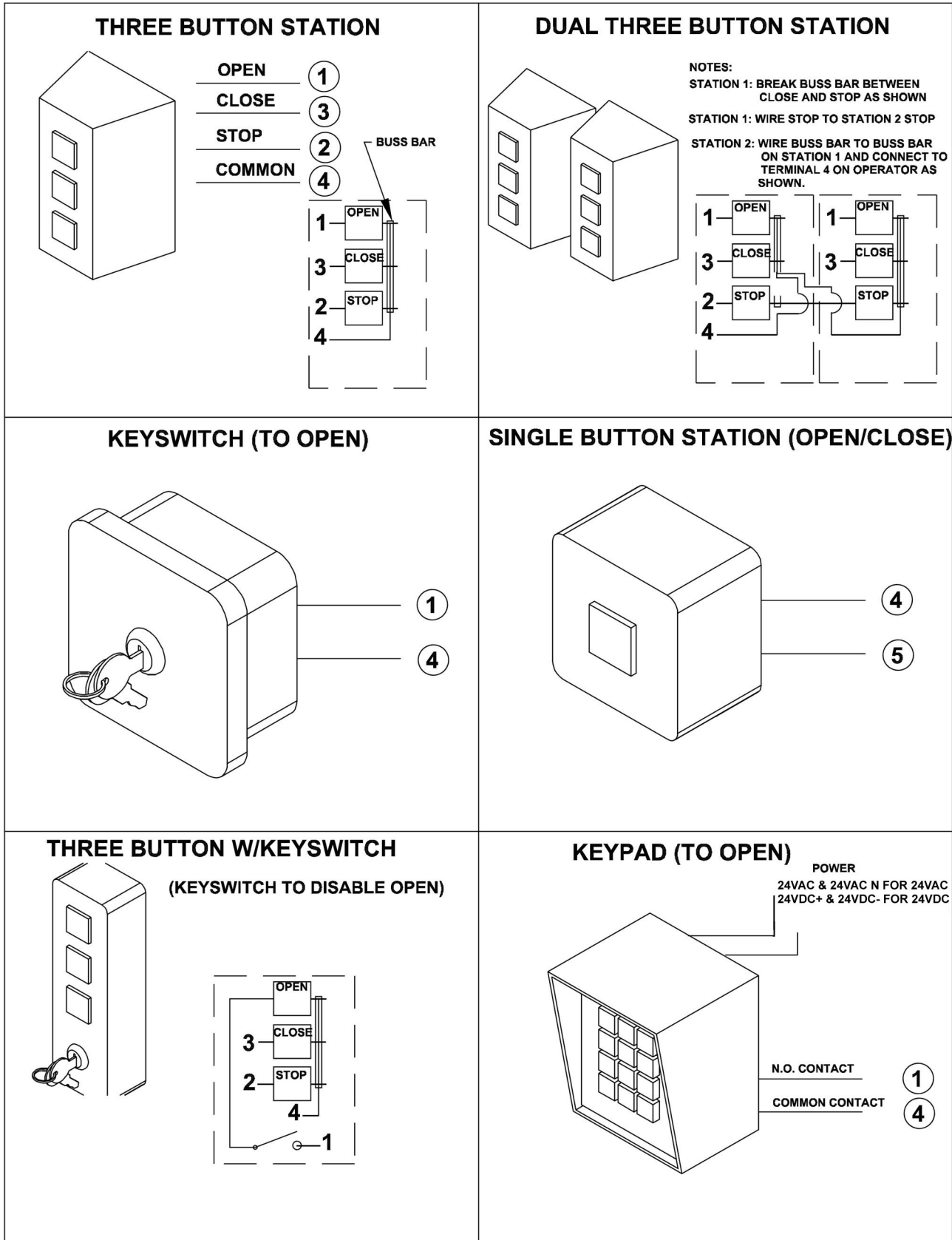

SWR • SWC • SWD OPERATOR INSTALLATION GUIDE

CONTROL and ACCESSORY CONNECTION ILLUSTRATIONS

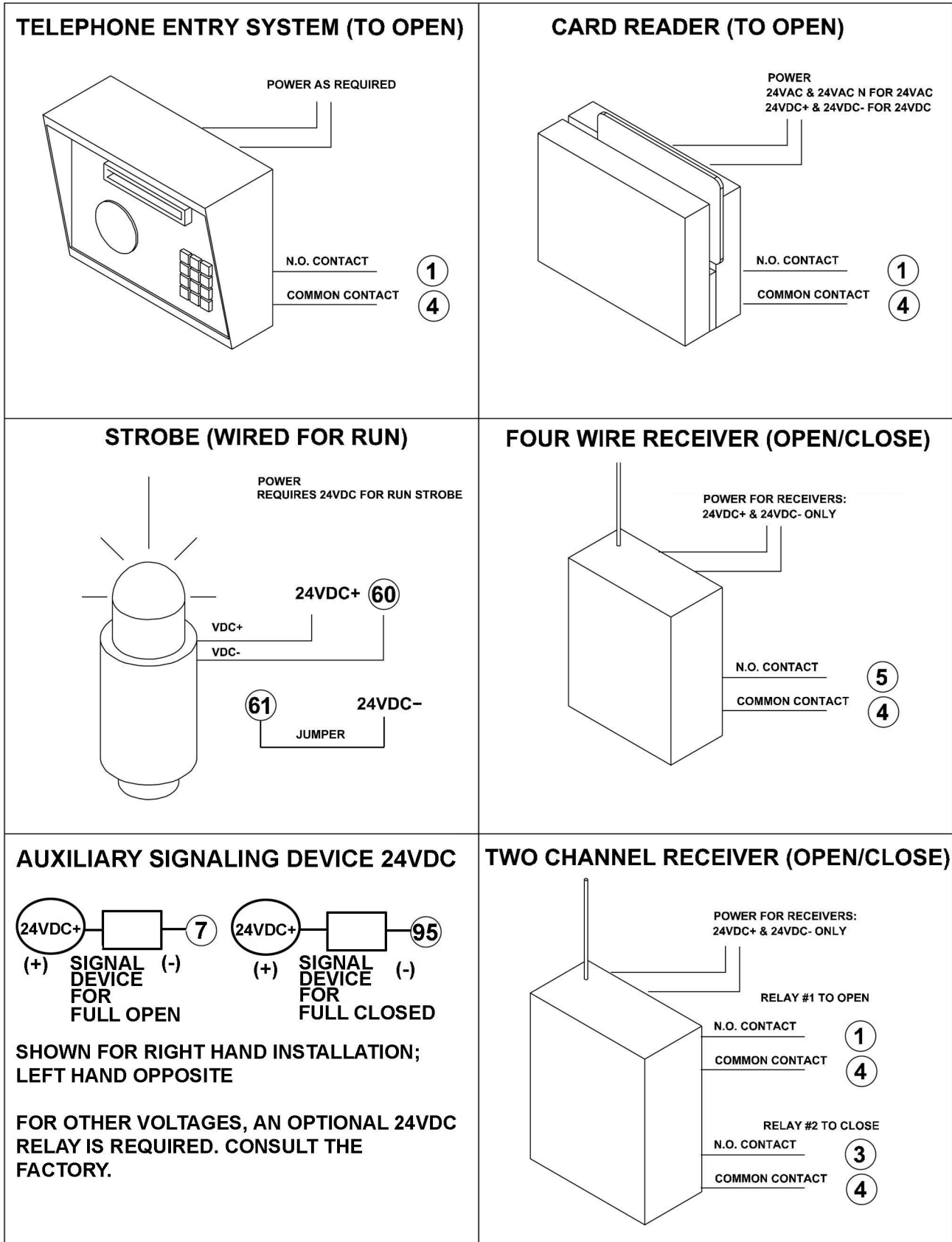

SWR • SWC • SWD OPERATOR INSTALLATION GUIDE

CONTROL and ACCESSORY CONNECTION ILLUSTRATIONS

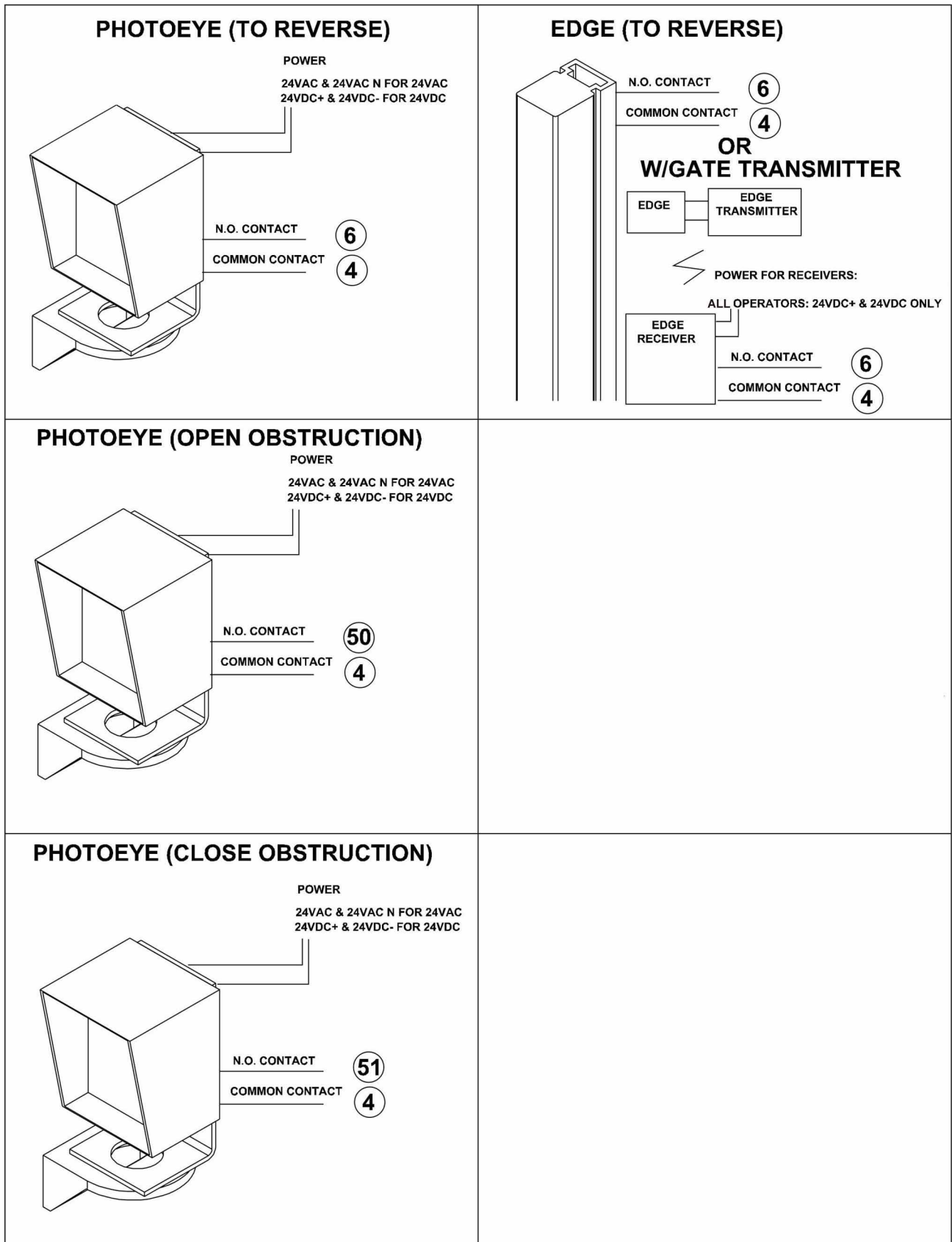

SWR • SWC • SWD OPERATOR INSTALLATION GUIDE

CONTROL and ACCESSORY CONNECTION ILLUSTRATIONS

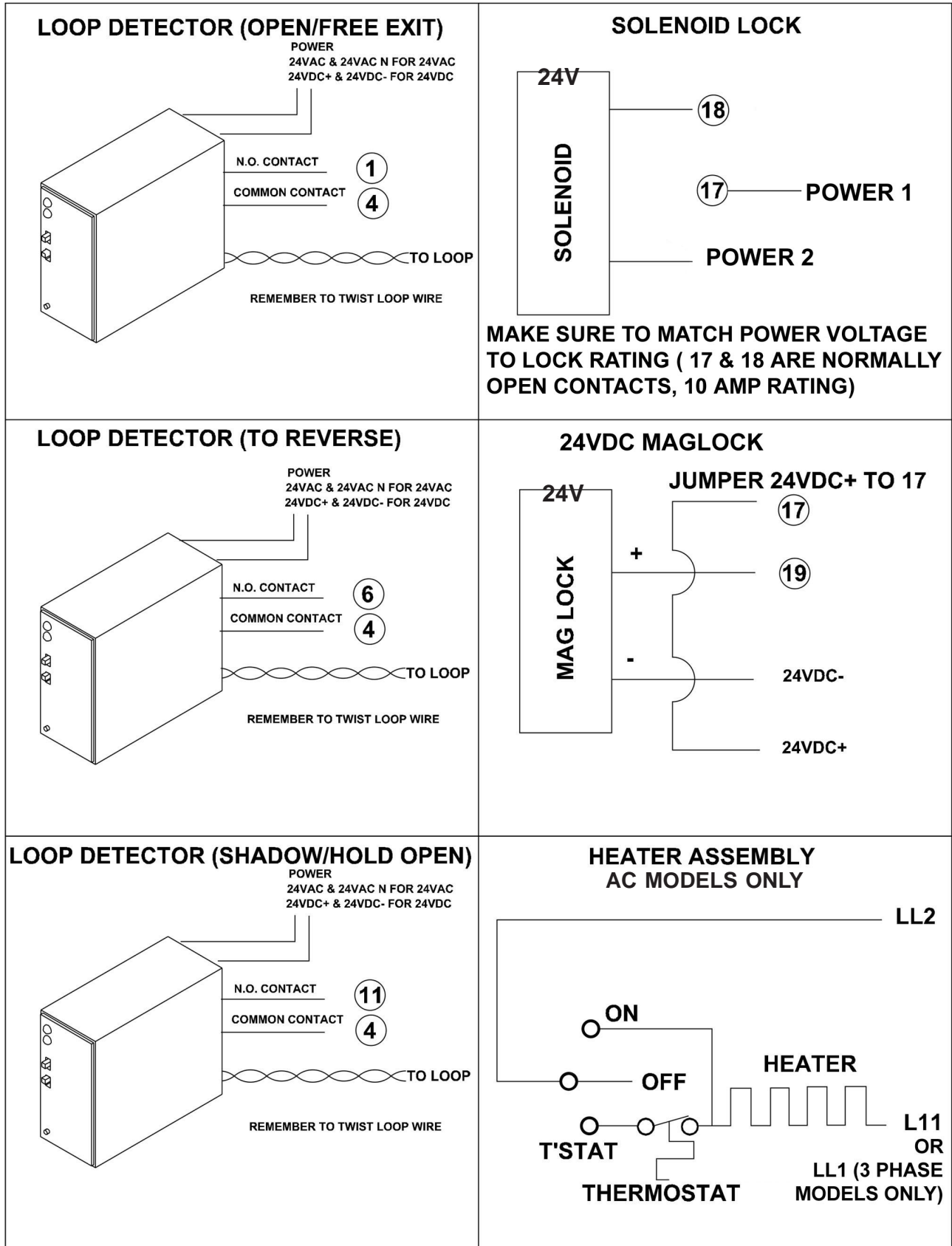

SWR • SWC • SWD OPERATOR INSTALLATION GUIDE

LOOP LAYOUT ILLUSTRATION

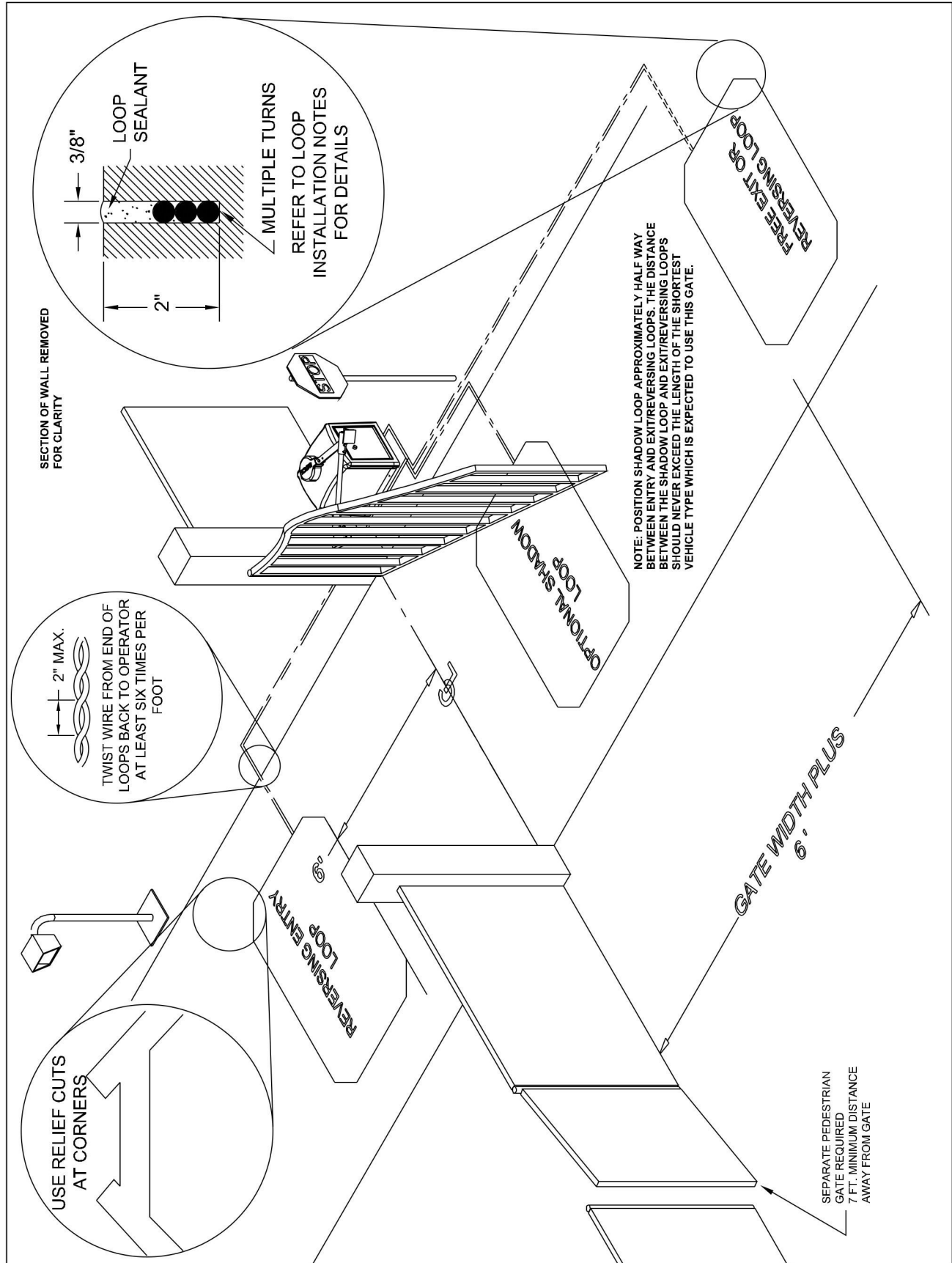

Refer to Connection Descriptions on page 11 and Loop Accessory Connections on page 19 for additional details.

SWR • SWC • SWD OPERATOR INSTALLATION GUIDE

EDGE LAYOUT ILLUSTRATION

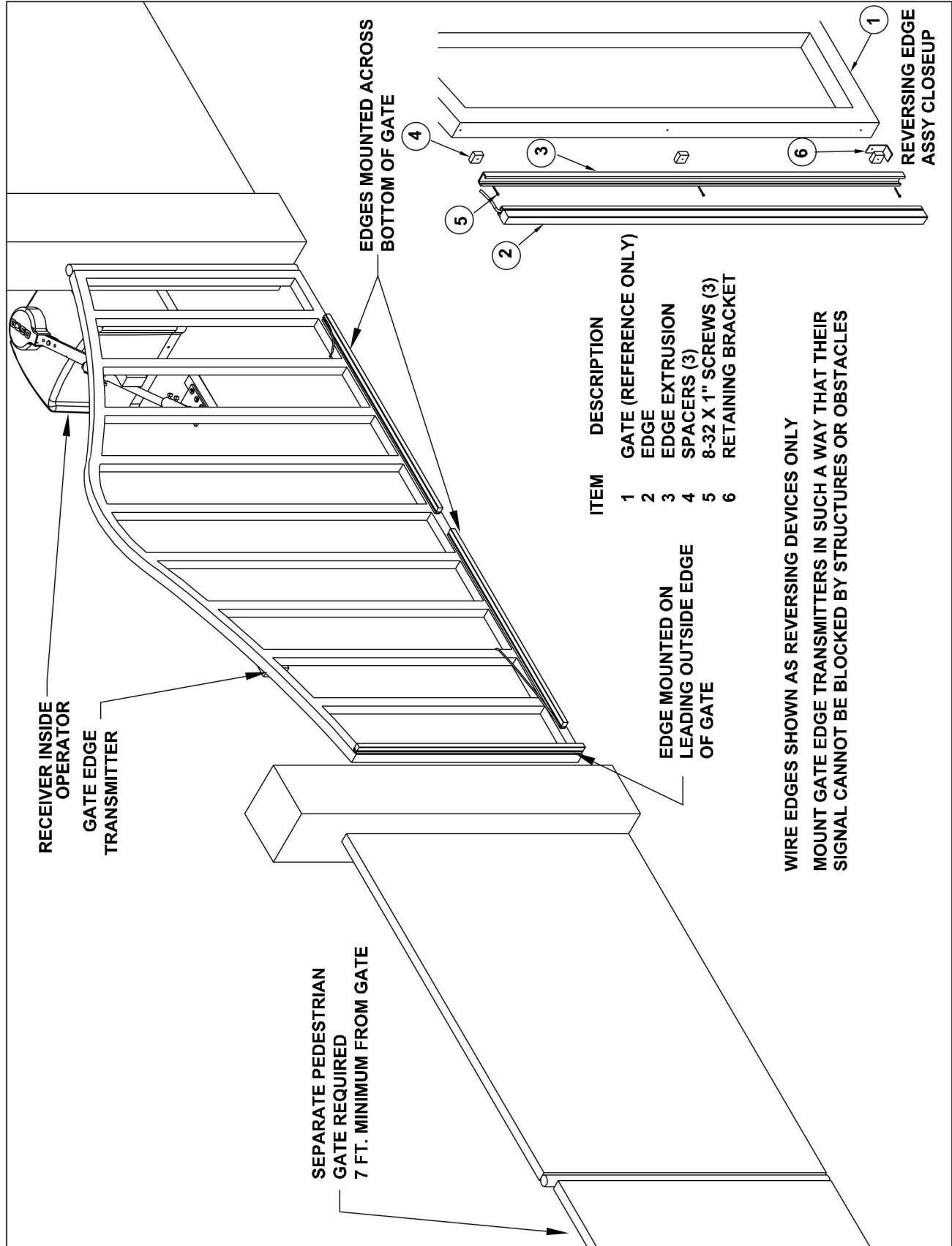

Refer to Connection Descriptions on page 11 and Contact Edge Connections on page 18 for additional details.

SWR • SWC • SWD OPERATOR INSTALLATION GUIDE

PHOTOEYE ILLUSTRATION

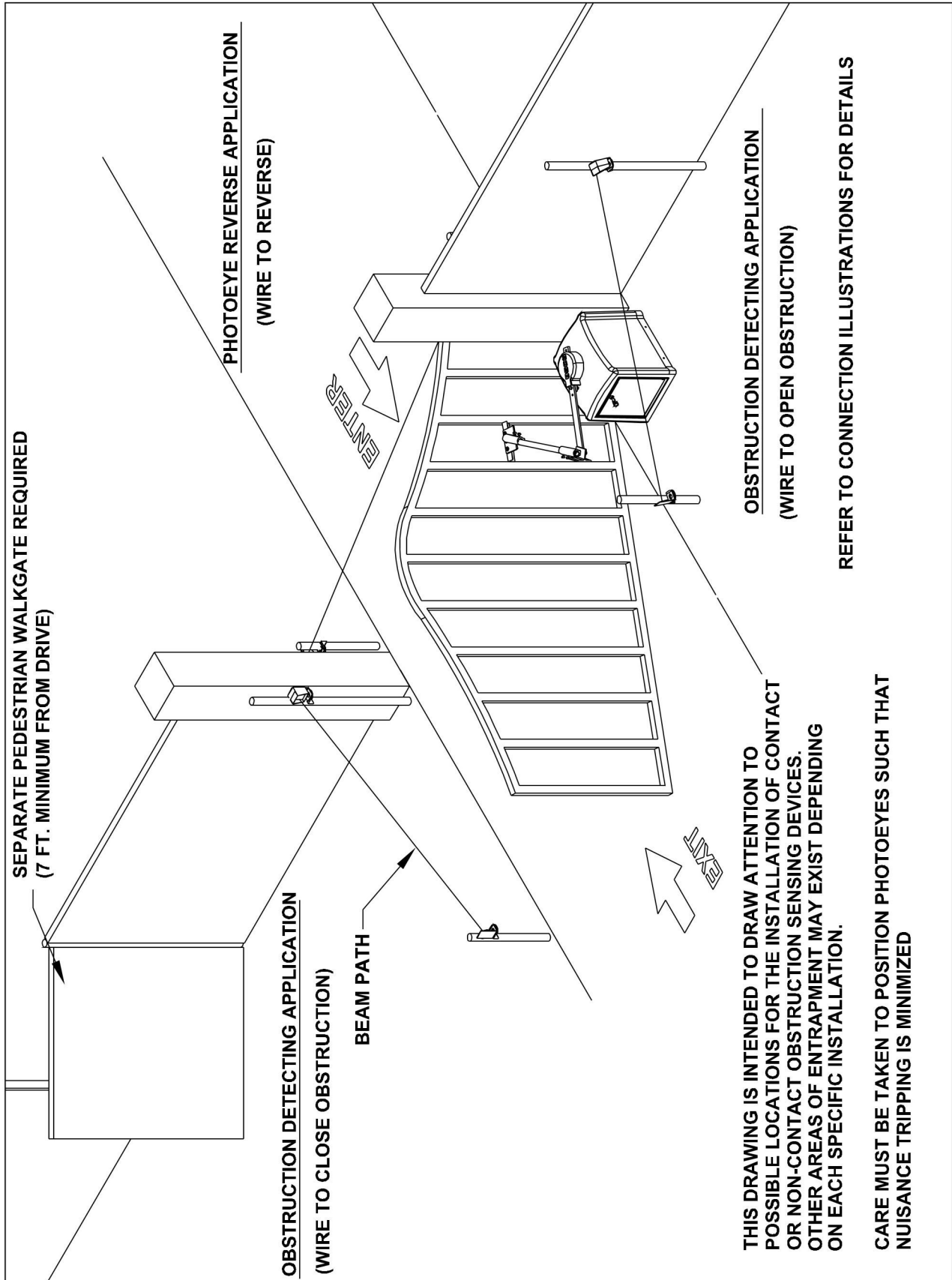

Refer to Connection Descriptions on page 11 and Photoeye Accessory Connections on page 18 for additional details.

TROUBLESHOOTING

Operator fails to start:

- A. If the operator has been running a large number of cycles, the motor may have gotten hot and tripped the overload. Allow the motor to cool down and the overload will reset automatically.
- B. Make sure you have power at the master distribution panel and that the power has not been turned off.
- C. The secondary fuse on the control board may have blown. Replace the fuse (refer to control box parts list on page 28 [SWR & SWC] and page 31 [SWD] for part number information).

Motor operates, but gate does not move:

- A. In operators with torque limiters and friction pad clutches, check for signs of slipping. You can mark the sprocket and clutch with a yellow or white grease pen and watch for the lines to move apart if slipping is taking place. Adjust the torque limiter tighter if this is the problem.
- B. Check for broken chain or worn belts.
- C. Check all setscrews on pulleys and sprockets and tighten them if necessary, and check for keys which may have fallen loose from keyways.

Motor sounds like it is working harder than normal:

- A. Make sure the gate is moving freely and without binding throughout its entire travel.
- B. Check the drive chain for obstructions (if the operator has one).
- C. If the operator has an internal brake mechanism, make sure it is releasing.

Limit switch getting out of time:

- A. Check for proper tension on all limit chains to be sure there is no jumping taking place. Mark one tooth and its corresponding link and run the gate. If the marks have moved, the chain is skipping.
- B. Check the setscrews in limit cams and limit sprockets for tightness. In rotary limit boxes, check the rotary limit nut for sloppiness or stripped threads. Replace if necessary.

Gate stopping part way open or closed (but no visible obstruction):

- A. The control board may have received a false obstruction input triggered by current sensing set too low. Make sure the gate moves freely through its entire travel before adjusting the current sensing.
- B. The maximum run timer may have counted down and expired. This can be caused by having the timer set too low, if a chain or belt is broken, or if a sprocket or pulley is slipping. When the timer expires, the gate stops and an alarm will sound.
- C. An obstruction signal from an accessory wired to the obstruction input may have triggered falsely. Check the control board for lit L.E.D. indicators for any of the following inputs: safety, shadow, open obstruction, close obstruction, stop, etc. If any are lit when the operator should be running, remove all devices hooked to that function and hook them up one at a time and try to run the operator until the problem device is found. Refer to page 13 for details on the control board indicators.

Gate staying open with automatic system:

- A. If there are vehicle detectors in your machine which are set up for reverse, one of your loops or loop detectors may be sending a false signal. Disconnect the wire harness and try running the operator.
- B. An opening or reversing device may be stuck or malfunctioning. Try disconnecting these devices and hook them back up one at a time and try running the operator until the malfunctioning device is found.
- C. Make sure the close limit switch isn't activated. If it is, the operator will think the gate is already closed.

HOW TO ORDER REPLACEMENT PARTS

Use the part numbers listed on the following pages. Contact your **local OSCO dealer** or **distributor** to order parts.

1. Supply the model number and serial number of your operator.
2. Specify the quantity of pieces needed and order by part number and name of part.
3. State whether to ship by freight, truck, parcel post, UPS or air express.
4. State whether transportation charges are to be prepaid or collect.
5. Specify name and address of person or company to whom parts are to be shipped.
6. Specify name and address of person or company to whom invoice is to be sent.

SWR • SWC • SWD OPERATOR INSTALLATION GUIDE

MODEL **SWR** MECHANICAL PARTS EXPLODED VIEW

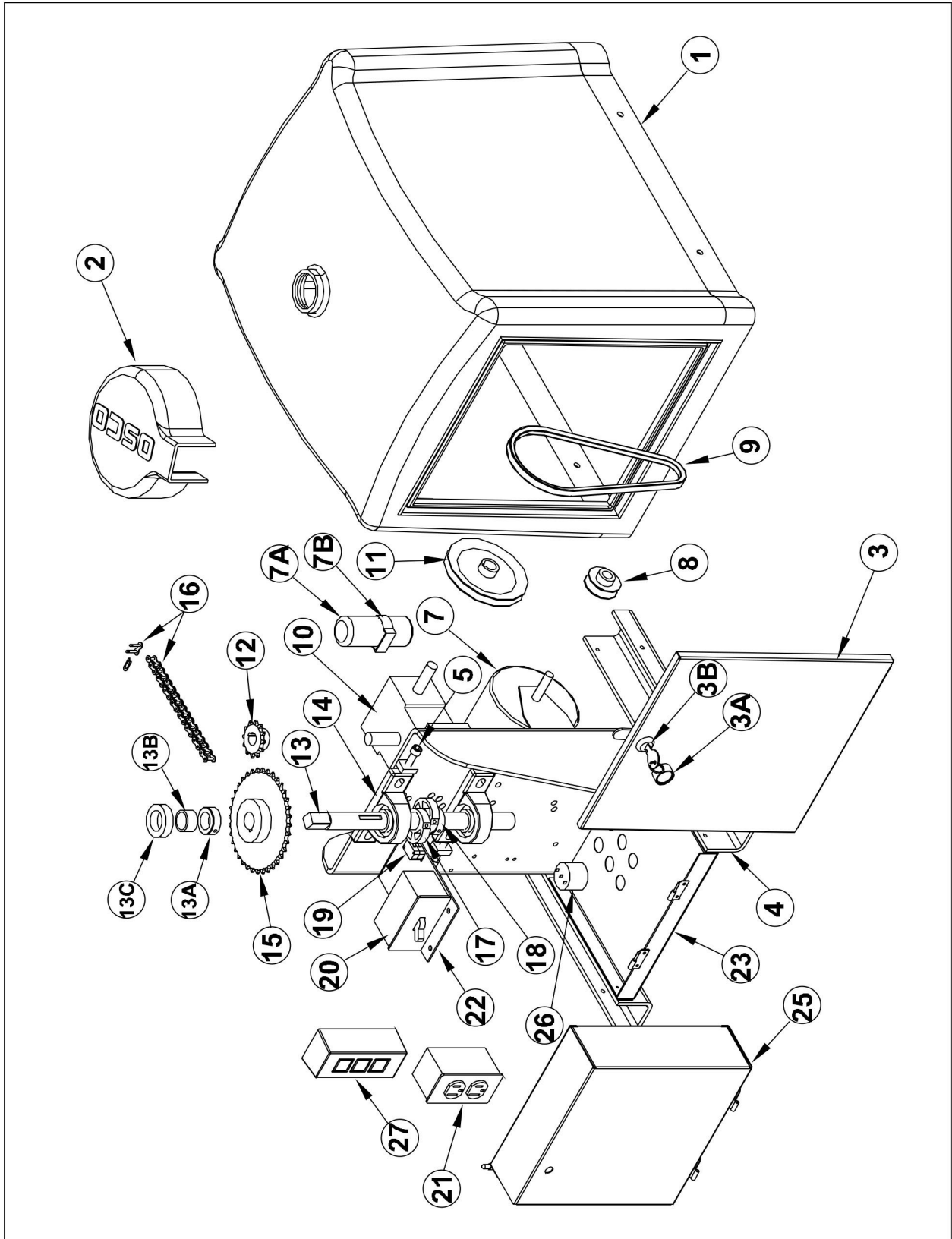

SWR • SWC • SWD OPERATOR INSTALLATION GUIDE

MODEL **SWR** MECHANICAL PARTS LIST

<u>REF. NO.</u>	<u>PART NO.</u>	<u>DESCRIPTION</u>	<u>REF. NO.</u>	<u>PART NO.</u>	<u>DESCRIPTION</u>
1	2300-925-BEIGE	Operator Cover, tan	19	2500-2347	Limit Switch
	2300-925-BLACK	Operator Cover, black			
	2300-925-GRANIT	Operator Cover, granite			
2	2300-926-BEIGE	Rain Cap, tan	20	2510-350-A	Power On/Off Switch Assembly, 115V Switch only
	2300-926-BLACK	Rain Cap, black		2500-1957	
	2300-926-GRANIT	Rain Cap, granite		2510-252-H	Power On/Off Switch Assembly, 230V Power Switch
3	2100-2030-BEIGE	Access Door, tan no Lock or Reset Button	21	2510-353-A	115VAC Outlet Assembly (for 115VAC units only)
	2100-2030-BT	Access Door, black no Lock or Reset Button		2500-1956	Outlets only
	2100-2030-WG	Access Door, gray no Lock or Reset Button	22	2100-2019	Power Switch Mounting Bracket
3A	2510-354	Plunger Reset Assembly	23	2100-2024	Accessory Mounting Shelf
	2500-2240	Plunger Reset Button		2200-874-PLT	Hinge, Male for Control Box
	2500-2241	Plunger Extension only			
3B	2200-790	Lock for Cover, with Keys	25	Controller	(for Controller Parts List see next page)
4	2110-785	Frame Assembly	26	2500-867	Alarm
5	2400-509	Socket Head Cap Screw, 3/8-16 x 1 1/2"	27	2510-064	Three-Button Station Assembly
7	2510-274	Motor Assembly, 1/2 HP, 115VAC, with Harness	<u>Optional Parts:</u>		
	2510-275	Motor Assembly, 1/2 HP, 230VAC, with Harness		2120-483	Post Mounting kit
7A	2500-1041	Capacitor for 115VAC		2220-047	3" Torque Limiter with Bushing and 40-A-36 Sprocket
	2500-552	Capacitor for 230VAC		2200-591	Friction Disc Pair for Torque Limiter
7B	2200-872	Capacitor Clamp		2200-593	Bushing for Torque Limiter
8	2200-132	Pulley, 2", 5/8" bore			
9	2200-208	V-belt, 4L, 26"			
10	2200-926	Gear Reducer, 60:1			
11	2100-388	Pulley, 5", 5/8" bore			
12	2200-190	Sprocket, 40-B-12, 3/4" bore			
13	2100-2020-PLT	Drive Shaft			
13A	2200-015	Shaft Collar, 1" diameter, 9/16 LTB			
13B	2100-519-PLT	Sleeve Spacer			
13C	2200-016	Moisture Seal			
14	2200-274	Pillow Block Bearing, 1" diameter			
15	2200-376	Sprocket, 40-B-36, 1" bore			
16	2200-673	#40 Chain, 21 Links			
	2200-006	#40 Master Link			
17	2100-1748	Limit Cam			
18	2200-015	Shaft Collar, 1" diameter, 9/16 LTB			

MODEL **SWC** MECHANICAL PARTS EXPLODED VIEW

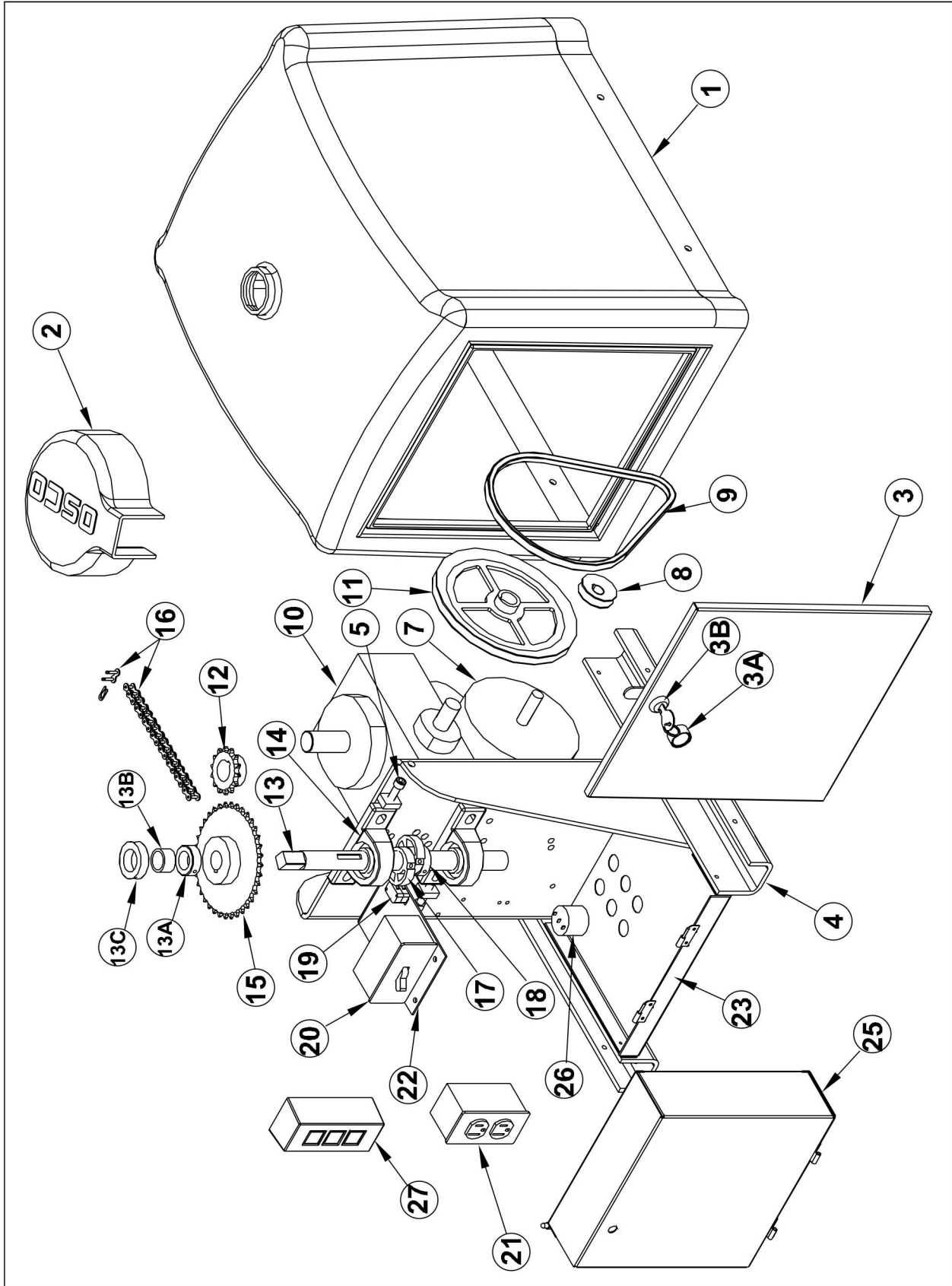

SWR • SWC • SWD OPERATOR INSTALLATION GUIDE

MODEL **SWC** MECHANICAL PARTS LIST

REF. NO.	PART NO.	DESCRIPTION	REF. NO.	PART NO.	DESCRIPTION
1	2300-925-BEIGE	Operator Cover, tan	13	2100-2020-PLT	Drive Shaft
	2300-925-BLACK	Operator Cover, black	13A	2200-015	Shaft Collar, 1" diameter, 9/16 LTB
	2300-925-GRANIT	Operator Cover, granite	13B	2100-519-PLT	Sleeve Spacer
2	2300-926-BEIGE	Rain Cap, tan	13C	2200-016	Moisture Seal
	2300-926-BLACK	Rain Cap, black			
	2300-926-GRANIT	Rain Cap, granite	14	2200-274	Pillow Block Bearing, 1" diameter
3	2100-2030-BEIGE	Access Door, tan no Lock or Reset Button	15	2200-376	Sprocket, 40-B-36, 1" bore (for 1/2 and 3/4 HP)
	2100-2030-BT	Access Door, black no Lock or Reset Button		2200-959	Sprocket, 40-B-40, 1" bore (for 1 HP)
	2100-2030-WG	Access Door, gray no Lock or Reset Button	16	2200-972	#40 Chain, 24 Links (for 1/2 and 3/4 HP)
3A	2510-354	Plunger Reset Assembly		2200-973	#40 Chain, 26 Links (for 1 HP)
	2500-2240	Plunger Reset Button		2200-006	#40 Master Link
	2500-2241	Plunger Extension only		2400-145	#40 Half Link
3B	2200-790	Lock for Cover, with Keys			
4	2110-785	Frame Assembly	17	2100-1748	Limit Cam
5	2400-509	Socket Head Cap Screw, 3/8-16 x 1 1/2"	18	2200-015	Shaft Collar, 1" diameter, 9/16 LTB
			19	2500-2347	Limit Switch
			20	2510-350-A 2500-1957	Power On/Off Switch Assembly, 115V Switch only
7	2500-2307	1/2 HP, 115V, 1 Phase		2510-252-H	Power On/Off Switch Assembly, 230V
	2500-2308	1/2 HP, 208/230V, 1 Phase		2500-2205	Power Switch
	2500-2309	3/4 HP, 115V, 1 Phase			
	2500-2310	3/4 HP, 208/230V, 1 Phase			
	2500-2311	1 HP, 115V, 1 Phase			
	2500-2312	1 HP, 208/230V, 1 Phase			
		Motors	21	2510-353-A	115VAC Outlet Assembly (for 115VAC units only)
		Capacitors		2500-1956	Outlets only
	2500-2336	Capacitor for 2500-2307 Motor			
	2500-2337	Capacitor for 2500-2308 Motor			
	2500-1926	Capacitor #1 for 2500-2309 Motor	22	2100-2019	Power Switch Mounting Bracket
	2500-1930	Capacitor #2 for 2500-2309 Motor			
	2500-1931	Capacitor for 2500-2310 Motor	23	2100-2024	Accessory Mounting Shelf
	2500-2338	Capacitor for 2500-2311 Motor		2200-874-PLT	Hinge, Male for Control Box
	2500-1932	Capacitor for 2500-2312 Motor			
8	2200-012	Pulley, 2", 5/8" bore (for 1/2 and 3/4 HP)	25	Controller (for Controller Parts List see next page)	
			26	2500-867	Alarm
			27	2510-064	Three-Button Station Assembly
9	2200-013	V-Belt, 31" (for 1/2 and 3/4 HP)			
	2200-931	V-Belt, 30" (for 1 HP only)			
10	2200-081	Gear Reducer, 60:1 (for 1/2 and 3/4 HP)		2120-483	Post Mounting Kit
				2220-048	5" Torque Limiter with Bushing and 40-A-36 Sprocket for 1/2 and 3/4 HP
	2200-957	Gear Reducer, 60:1 (for 1 HP)		2220-049	5" Torque Limiter with Bushing and 40-A-40 Sprocket for 1 HP
11	2200-885	Pulley, 8", 3/4" bore (for 1/2 and 3/4 HP)		2300-381	Friction Disc pair for 5" Torque Limiter
				2200-782	Bushing for 5" Torque Limiter
12	2200-084	Sprocket, 40-B-13, 1" bore (for 1/2 and 3/4 HP)			
	2200-958	Sprocket, 40-B-14, 1 1/8" bore (for 1 HP)			

SWR • SWC • SWD OPERATOR INSTALLATION GUIDE

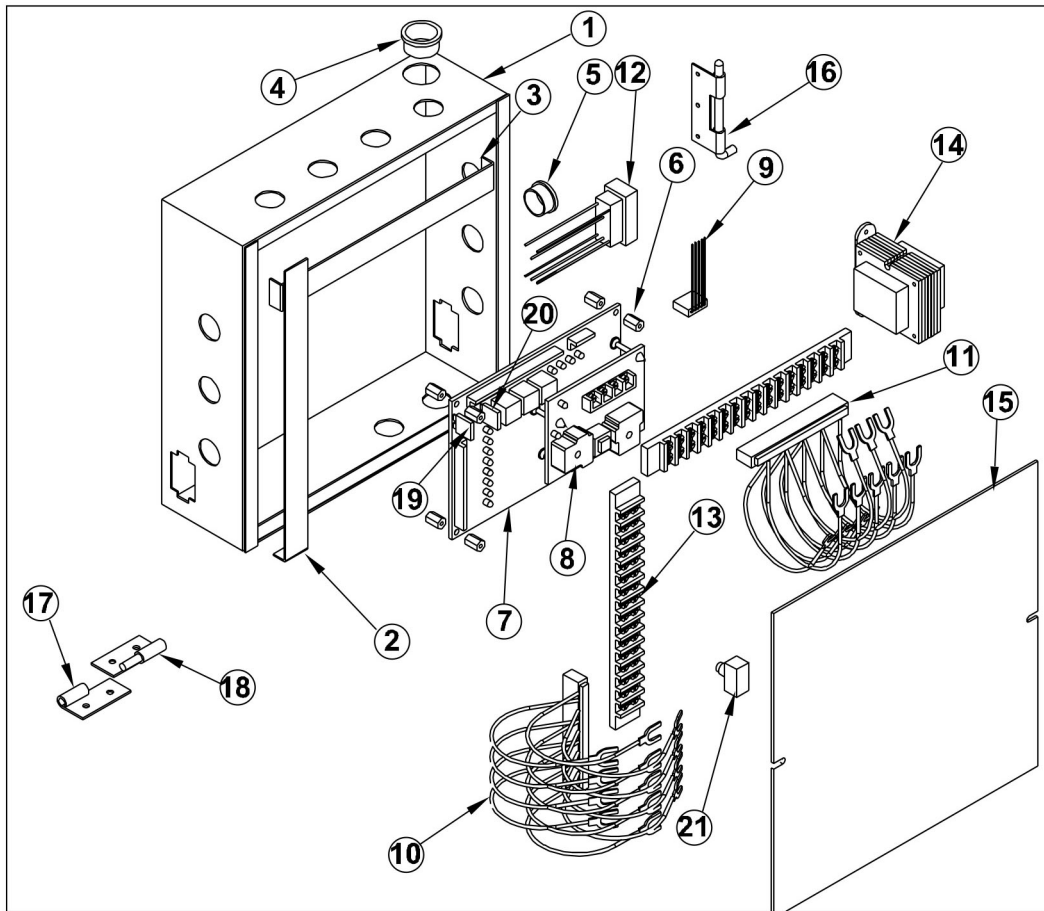

MODELS **SWR • SWC** CONTROL BOX PARTS LIST

REF NO.	PART NO.	DESCRIPTION	REF NO.	PART NO.	DESCRIPTION
1	2100-1778-PLT	Control Box Wrapper	15	2300-696	Clear Control Box Cover
2	2100-1762	Terminal Strip Bracket, output side	16	2200-940	Pull Pin Disconnect
3	2100-1761	Terminal Strip Bracket, input side	17	2200-873-PLT	Control Box Hinge, Female (riveted to control box)
4	2300-735	Heyco Bushing, 1.09 diameter	18	2200-874-PLT	Control Box Hinge, Male (riveted to accessory shelf)
5	2200-122	Heyco Bushing, .87 diameter	19	2500-1966	2 Amp Fuse for Control Board
6	2500-1948	Control Board Standoff	20	2500-1975	3 Amp Fuse for Control Board
7	2510-268	Control Board		2520-391-F	Complete Controller Assembly 115VAC (order limit harness and mounting hardware separately)
8	2500-1946	AC Motor Drive Board		2520-392-F	Complete Controller Assembly 230VAC (order limit harness and mounting hardware separately)
	2510-244	Control Board with AC Motor Board			
9	2510-380	Limit Switch Harness Assembly	21	2500-1495	Stop/Reset Button
10	2510-249	Input Wire Harness Assembly			
11	2510-250	Output Wire Harness Assembly			
12	2510-261	Control Box Motor Harness Assembly			
13	2500-071	Terminal Strip, 16-141			
14	2500-212	Transformer, 115/24VAC, 40VA			
	2500-791	Transformer, 230/24VAC, 40VA			

MODEL **SWD** MECHANICAL PARTS EXPLODED VIEW

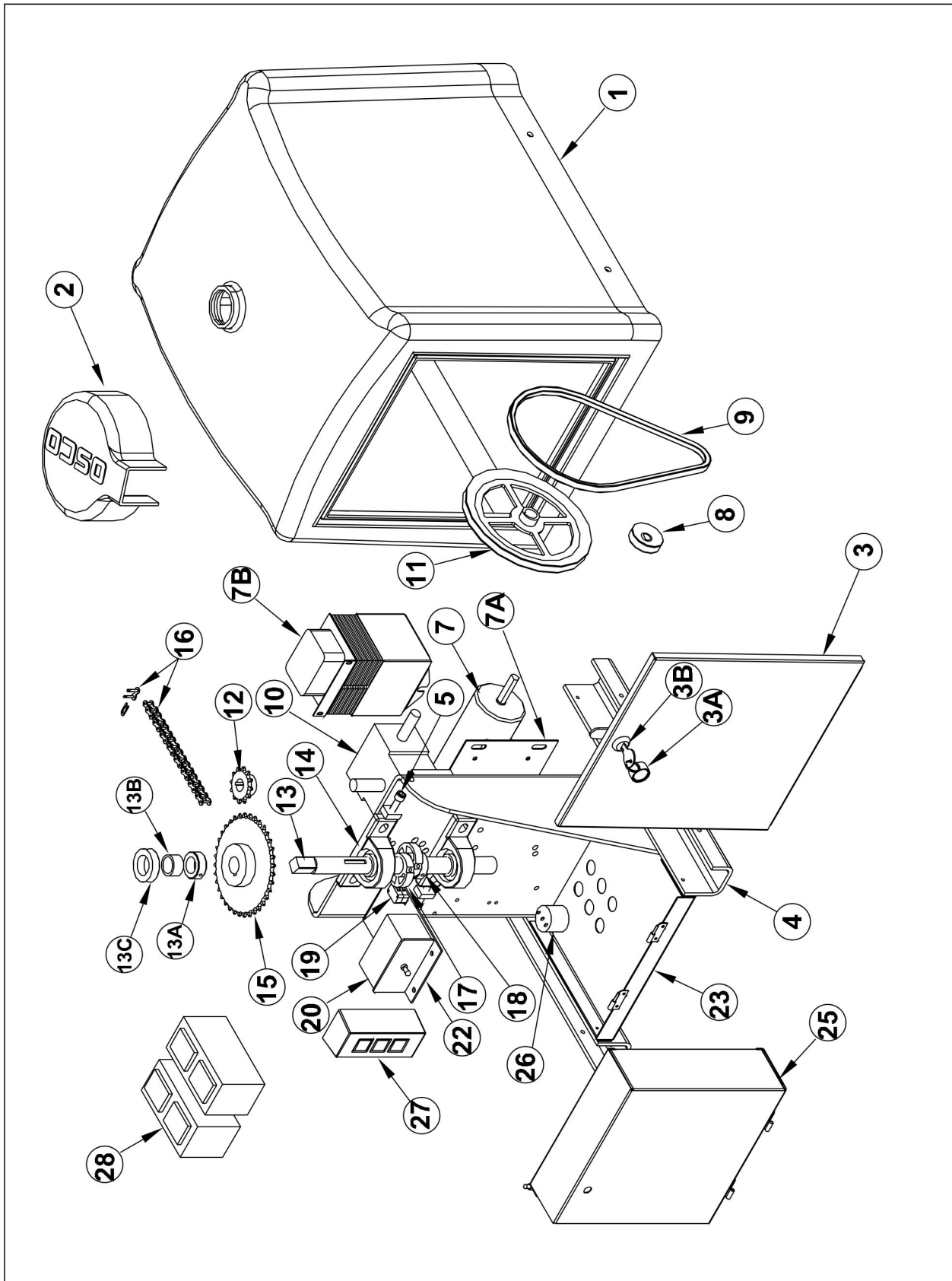

SWR • SWC • SWD OPERATOR INSTALLATION GUIDE

MODEL **SWD** MECHANICAL PARTS LIST

REF. NO.	PART NO.	DESCRIPTION	REF. NO.	PART NO.	DESCRIPTION
1	2300-925-BEIGE 2300-925-BLACK 2300-925-GRANIT	Operator Cover, tan Operator Cover, black Operator Cover, granite	19	2500-2347	Limit Switch
2	2300-926-BEIGE 2300-926-BLACK 2300-926-GRANIT	Rain Cap, tan Rain Cap, black Rain Cap, granite	20	2510-266-D 2500-2205	Power On/Off Switch Assembly Switch only
3	2100-2030-BEIGE 2100-2030-BT 2100-2030-WG	Access Door, tan no Lock or Reset Button Access Door, black no Lock or Reset Button Access Door, gray no Lock or Reset Button	22	2100-2019	Power Switch Mounting Bracket
3A	2510-354 2500-2240 2500-2241	Plunger Reset Assembly Plunger Reset Button Plunger Extension only	23	2100-2024 2200-874-PLT	Accessory Mounting Shelf Hinge, Male for Control Box
3B	2200-790	Lock for Cover, with Keys	25	Controller (for Controller Parts List see next page)	
4	2110-785	Frame Assembly	26	2500-867	Alarm
5	2400-509	Socket Head Cap Screw, 3/8-16 x 1 1/2"	27	2510-064	Three Button Station Assembly
7	2500-1902	Motor, 24VDC	28	2510-182 2500-1118 2300-450	Battery Assembly Battery, 12V (2 required) Velcro Tape, per foot
7A	2100-2037	Motor Mounting Plate	<u>Optional Parts:</u>		
7B	2510-223 2500-1768 2500-1776 2500-1819 2500-1742	Transformer Assembly Bridge Rectifier Transformer only, 115/24V, 250VA Fuse Holder Fuse, 6 Amp, Slow-Blow	2120-483		Post Mounting Kit
8	2200-411	Pulley, 1 1/2", 1/2" bore	2220-047		3" Torque Limiter with Bushing and 40-A-36 Sprocket
9	2200-931	V-belt, 4L, 30"	2200-591		Friction Disc Pair for Torque Limiter
10	2200-926	Gear Reducer, 60:1	2200-593		Bushing for Torque Limiter
11	2200-429	Pulley, 7", 5/8" bore			
12	2200-190	Sprocket, 40-B-12, 3/4" bore			
13	2100-2020-PLT	Drive Shaft			
13A	2200-015	Shaft Collar, 1" diameter, 9/16 LTB			
13B	2100-519-PLT	Sleeve Spacer			
13C	2200-016	Moisture Seal			
14	2200-274	Pillow Block Bearing, 1" diameter			
15	2200-376	Sprocket, 40-B-36, 1" bore			
16	2200-673 2200-006	#40 Chain, 21 Links #40 Master Link			
17	2100-1748	Limit Cam			
18	2200-015	Shaft Collar, 1" diameter, 9/16 LTB			

SWR • SWC • SWD OPERATOR INSTALLATION GUIDE

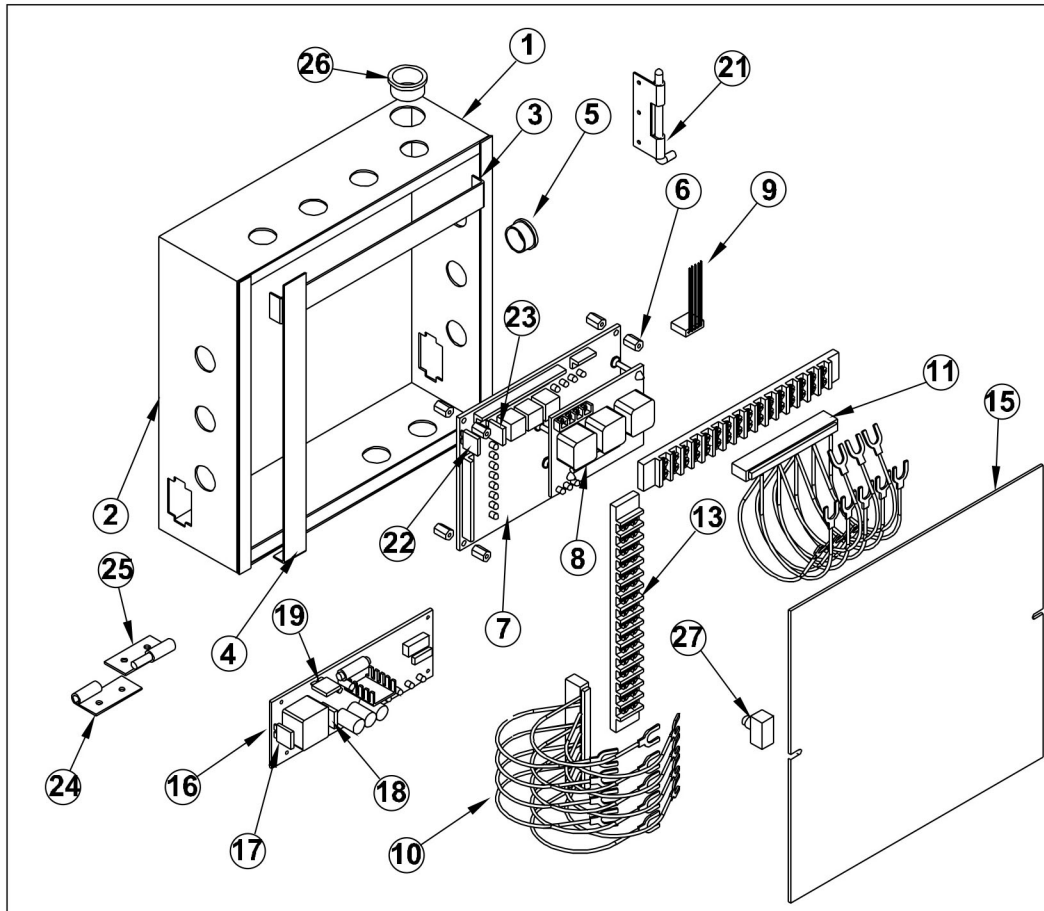

MODEL **SWD** CONTROL BOX PARTS LIST

<u>REF NO.</u>	<u>PART NO.</u>	<u>DESCRIPTION</u>	<u>REF NO.</u>	<u>PART NO.</u>	<u>DESCRIPTION</u>
1	2100-1778-PLT	Control Box Wrapper	21	2200-940	Pull Pin Disconnect
3	2100-1762	Terminal Strip Bracket, output side		2500-867	Alarm, 24VDC (not shown)
4	2100-1761	Terminal Strip Bracket, input side	23	2500-1975	3 Amp Fuse for Control Board
5	2200-122	Heyco Bushing, .87 diameter	24	2200-873-PLT	Control Box Hinge, Female (riveted to control box)
6	2500-1948	Control Board Standoff	25	2200-874-PLT	Control Box Hinge, Male (riveted to accessory shelf)
7	2510-269	Control Board DC		2520-393-E	Complete Controller Assembly 24VDC (order limit harness and mounting brackets separately)
8	2500-1947	DC Motor Drive Board	26	2300-735	Heyco Bushing, 1.09 diameter
	2510-245	Control Board with DC Motor Board	27	2500-1495	Stop/Reset Button
9	2510-380	Limit Switch Harness Assembly			
10	2510-249	Input Wire Harness Assembly			
11	2510-250	Output Wire Harness Assembly			
13	2500-071	Terminal Strip, 16-141 (2)			
15	2300-696	Clear Control Box Cover			
16	2500-2127-CB	DC Charger Board			
17	2500-2293	Circuit Breaker, 15 Amp Auto-Reset			
18	2500-2293	Circuit Breaker, 15 Amp Auto-Reset			
19	2500-1975	Fuse, 3 Amp			

SWR • SWC • SWD OPERATOR INSTALLATION GUIDE

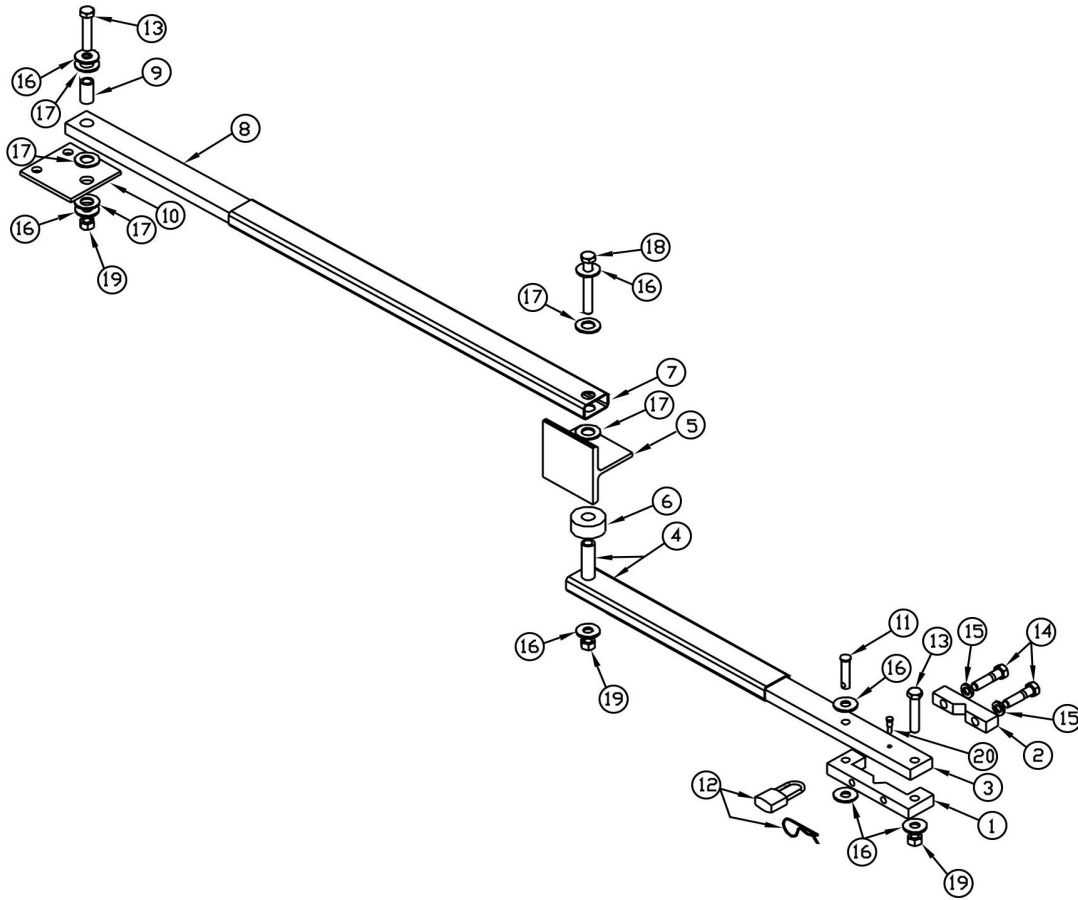

SWR • SWC • SWD GATE ARM ASSEMBLY PARTS LIST

<u>REF NO.</u>	<u>PART NO.</u>	<u>DESCRIPTION</u>
	2120-493	Complete Arm Assembly
1	2100-2068-PLT	Threaded Crank Block
2	2100-2069-PLT	V-Block for Crank Block
3	2100-2067	Crank Extension Solid Bar
4	2110-810	Crank Extension and Spacer Assembly
5	2100-1924-PLT	Overtravel Stop
6	2300-969	Plastic Elbow Offset Spacer
7	2100-2072	Gate Arm Link Tube
8	2100-2071	Solid Link Bar
9	2200-964	Gate Plate Tube Spacer
10	2100-2070	Gate Plate
11	2400-511	Disconnect Pin
12	2400-351	Disconnect Hair Pin
	2200-034	Disconnect Lock (optional)
13	2400-512	Hex Head Screw, grade 8, 1/2-13 x 2 1/2"
14	2400-505	Hex Head Screw, grade 8, 1/2-13 x 2"
15	2400-513	Lockwasher, grade 8, 1/2"
16	2400-506	Flatwasher, grade 8
17	2300-238	Nylon Washer
18	2400-508	Hex Head Screw, grade 8, 1/2-13 x 3 3/4"
19	2400-507	Nylon Insert Locknut, grade 8, 1/2-13
20	2400-510	Shoulder Bolt for Rain Cap, 1/4-20

SWR • SWC • SWD OPERATOR INSTALLATION GUIDE

MODEL SWD BATTERY MAINTENANCE

The gel-cell batteries in this operator require no routine maintenance. For assured continued performance, they should be replaced every year.

If power is to be removed for one week or more, disconnect the negative wire from the batteries as this will prevent deep discharging.

Fully charge before use after storage or upon initial installation.

MODEL SWD BRUSH REPLACEMENT

Brushes should be inspected every 100,000 cycles, (200,000 for BGU-D) or yearly, whichever comes first. The motor has two brushes, one on each side.

Original brushes are approximately 3/4" long and should be replaced when they are 1/4" long, or sooner. If brushes are allowed to wear beyond this point, permanent damage to the motor may result.

To inspect the brushes, remove retaining cap (A), with straight-blade screwdriver, and carefully pull assembly straight out. Measure remaining brush material (B).

To reinstall, place brush in hold, aligning rounded indentation (C), correctly with motor shaft. Gently push in spring and align contact with oval carrier, push in with retaining cap (D). Hold in place and thread cap into brush carrier. Do not overtighten or cap will crack! Repeat for other brush.

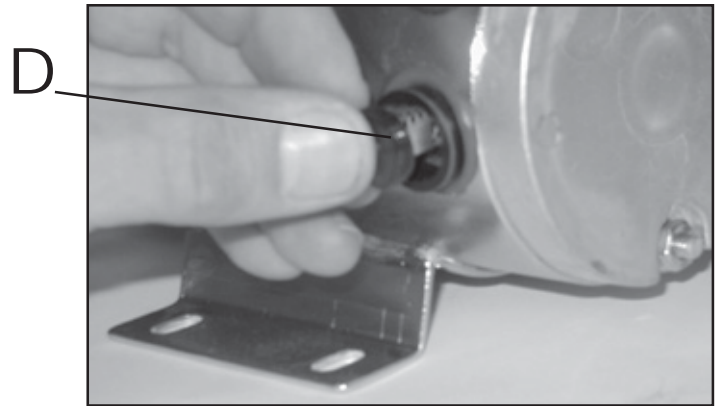
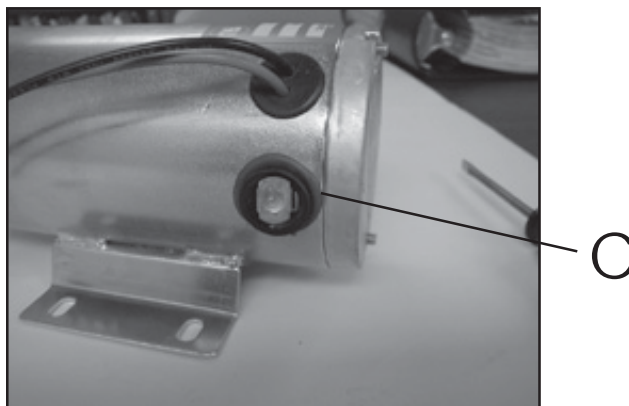
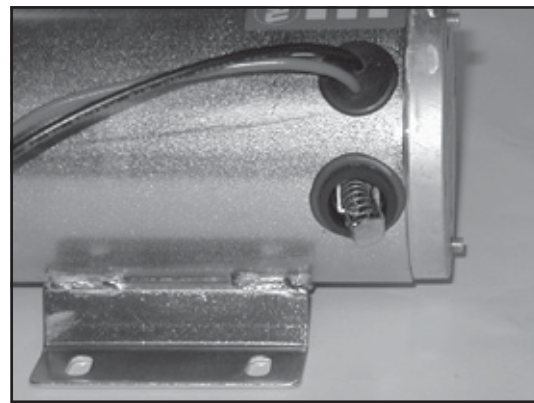
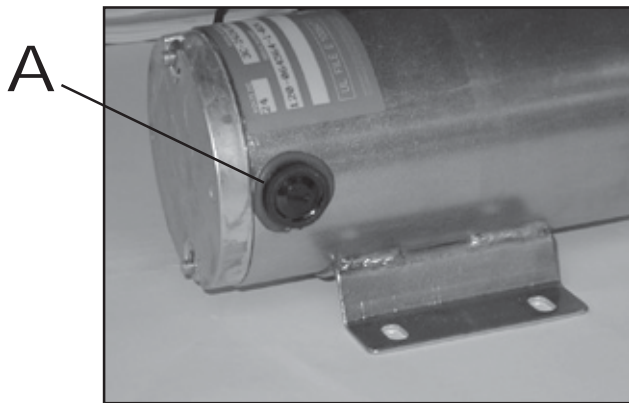
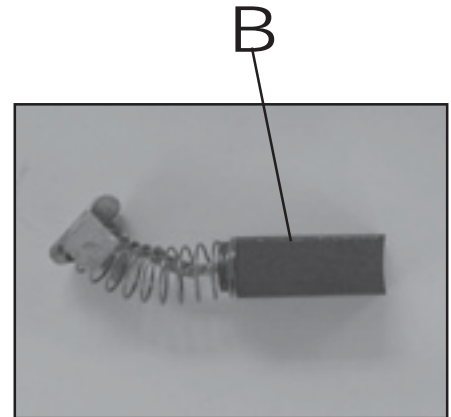

MATERIAL SAFETY DATA SHEET

MOBIL SHC 634

1. PRODUCT AND COMPANY IDENTIFICATION

PRODUCT NAME: MOBIL SHC 634
SUPPLIER: EXXONMOBIL CORPORATION
3225 GALLOWS RD.
FAIRFAX, VA 22037

24 - Hour Health and Safety Emergency (call collect): 609-737-4411
24 - Hour Transportation Emergency (Primary) CHEMTREC: 800-424-9300

Product and MSDS Information:	800-662-4525	703-846-6691
CHEMTREC:	800-424-9300	202-483-7616
MSDS Fax on Demand:	613-228-1467	
MSDS Internet Website:	http://emmsds.ihssolutions.com	

2. COMPOSITION/INFORMATION ON INGREDIENTS

CHEMICAL NAMES AND SYNONYMS: SYN. HYDROCARBONS AND ADDITIVES

GLOBALLY REPORTABLE MSDS INGREDIENTS:

None.

See Section 8 for exposure limits (if applicable).

3. HAZARDS IDENTIFICATION

Under normal conditions of use, this product is not considered hazardous according to regulatory guidelines (See section 15).

EMERGENCY OVERVIEW: Orange liquid. DOT ERG No. : NA

POTENTIAL HEALTH EFFECTS: Under normal conditions of intended use, this product does not pose a risk to health. Excessive exposure may result in eye, skin or respiratory irritation.

For further health effects/toxicological data, see Section 11.

4. FIRST AID MEASURES

EYE CONTACT: Flush thoroughly with water. If irritation occurs, call a physician.

SKIN CONTACT: Wash contact areas with soap and water. Remove and clean oil soaked clothing daily and wash affected area. (See Section 16 - Injection Injury)

INHALATION: Not expected to be a problem. However, if respiratory irritation, dizziness, nausea, or unconsciousness occurs due to excessive vapor or mist exposure, seek immediate medical assistance. If breathing has stopped, assist ventilation with a mechanical device or mouth-to-mouth resuscitation.

INGESTION: Not expected to be a problem. Seek medical attention if discomfort occurs. Do not induce vomiting.

Contact Factory for additional Sections mentioned above at 1-800-333-1717.

Date Prepared: February 02, 1996
 Supersedes: January 07, 1995
 MSDS Number: 225570

Cette fiche signalétique est aussi disponible en français

1. PRODUCT INFORMATION

Product Identifier: ESSO GEAR OIL GX 80W-90
 Application and Use: Premium quality multigrade extreme pressure gear oil for use in automotive applications including some manual transmissions.
 Product Description: A lubricating oil consisting of a saturated and unsaturated hydrocarbons derived from paraffinic distillate, and additives.

REGULATORY CLASSIFICATION

WHMIS: Not a controlled product
 CEPA: CANADIAN ENVIRONMENTAL PROTECTION ACT
 All components of this product are either on the Domestic Substances List (DSL) or are exempt.

TRANSPORTATION OF DANGEROUS GOODS INFORMATION

Shipping Name:	Petroleum Lubricating Oil		
Class:	Not regulated	Packing Group:	Not regulated
PIN Number:	Not regulated	Guide Number:	129

Please be aware that other regulations may apply.

TELEPHONE NUMBERS

Emergency 24 hr. 519-339-2145
 Technical Info. 800-268-3183

MANUFACTURER/SUPPLIER

IMPERIAL OIL
 Products Division
 111 St. Clair Ave. West
 Toronto, Ontario M5W 1K3
 416-968-4111

2. REGULATED COMPONENTS

The following components are defined in accordance with subparagraph 13(a) (I) to (IV) or paragraph 14(a) of the Hazardous Products Act:

NAME	%	CAS #
Not applicable		

3. TYPICAL PHYSICAL & CHEMICAL PROPERTIES

Physical State: Liquid
 Specific gravity: not available
 Viscosity: 15.50 cSt at 100 deg. C
 Vapour Density: not available
 Boiling point: 229 to 600 deg. C
 Evaporation rate: <0.1 (1=n-butylacetate)
 Solubility in water: negligible
 Freezing/Pour Point: -27 deg. C D97
 Odour Threshold: not available
 Vapour Pressure: <0.1 kPa at 20 deg. C
 Density: 0.89 g/cc at 15 deg. C
 Appearance/odour: Dark brown liquid, petroleum hydrocarbon odour.

4. HEALTH HAZARD INFORMATION

NATURE OF HAZARD:

INHALATION: Negligible hazard at normal temperatures (up to 38 deg. C). Elevated temperatures or mechanical action may form vapours, mists or fumes which may be irritating to the eyes, nose, throat and lungs. Avoid breathing vapours or mists.
 EYE CONTACT: Slightly irritating, but will not injure eye tissue.
 SKIN CONTACT: Low toxicity. Frequent or prolonged contact may irritate the skin.
 INGESTION: Low toxicity.
 ACUTE TOXICITY DATA: Based on animal testing data from similar materials and products, the acute toxicity of this product is expected to be:
 Oral: LD50 > 5000 mg/kg (rat)
 Dermal: LD50 > 3160 mg/kg (rabbit)
 Inhalation: LC50 > 5000 mg/m3 (rat)
 OCCUPATIONAL EXPOSURE LIMIT:
 ACGIH recommends: For oil mists, 5 mg/m3. Local regulated limits may vary.

5. FIRST AID MEASURES

INHALATION: Vapour pressure of this material is low and as such inhalation under normal conditions is usually not a problem. If overexposed to oil mist, remove from further exposure. Administer artificial respiration if breathing has stopped. Keep at rest. Call for prompt medical attention.
 EYE CONTACT: Flush eyes with large amounts of water until irritation subsides. If irritation persists, get medical attention.
 SKIN CONTACT: Flush with large amounts of water. Use soap if available. Remove severely contaminated clothing (including shoes) and launder before reuse. If irritation persists, seek medical attention.
 INGESTION: If swallowed, DO NOT induce vomiting. Keep at rest. Get prompt medical attention.

6. PREVENTIVE AND CORRECTIVE MEASURES

PERSONAL PROTECTION: The selection of personal protective equipment varies, depending upon conditions of use. In open systems where contact is likely, wear safety goggles, chemical-resistant overalls, and chemically impervious gloves. Where only incidental contact is likely, wear safety glasses with side shields. No other special precautions are necessary provided skin/eye contact is avoided. Where concentrations in air may exceed the occupational exposure limits given in Section 4 and where engineering, work practices or other means of exposure reduction are not adequate, approved respirators may be necessary to prevent overexposure by inhalation.

ENGINEERING CONTROLS: The use of local exhaust ventilation is recommended to control emissions near the source. Laboratory samples should be handled in a fumehood. Provide mechanical ventilation of confined spaces.

Esso Sheet 80W-90 082500

HANDLING, STORAGE AND SHIPPING: Keep containers closed. Handle and open containers with care. Store in a cool, well ventilated place away from incompatible materials. Do not handle or store near an open flame, sources of heat, or sources of ignition. Odorous and toxic fumes may form from the decomposition of this product if stored at temperatures in excess of 45 deg. C for extended periods of time or if heat sources in excess of 121 deg. C are used. Empty containers may contain product residue. Do not pressurize cut, heat, or weld empty containers. Do not reuse empty containers without commercial cleaning or reconditioning.

LAND SPILL: Eliminate source of ignition. Keep public away. Prevent additional discharge of material. If possible to do so without hazard. Prevent spills from entering sewers, watercourses or low areas. Contain spilled liquid with sand or earth. Recover by pumping or by using a suitable absorbent. Consult an expert of disposal or recovered material. Ensure disposal in compliance with government requirements and ensure conformity to local disposal regulations. Notify the appropriate authorities immediately. Take all additional action necessary to prevent and remedy the adverse effects of the spill.

WATER SPILL: Remove from surface by skimming or with suitable absorbents. If allowed by local authorities and environmental agencies, sinking and/or suitable dispersants may be used in unconfined waters. Consult an expert on disposal of recovered material. Ensure disposal in compliance with government requirements and ensure conformity to local disposal regulations. Notify the appropriate authorities immediately. Take all additional action necessary to prevent and remedy the adverse effects of the spill.

7. FIRE AND EXPLOSION HAZARD

Flashpoint and method: 178 deg. C COC D92
 Autoignition: NA Flammable Limits: LEL: NA UEL: NA

GENERAL HAZARDS:

Low hazard; liquids may burn upon heating to temperatures at or above the flash point. Decomposes; flammable/toxic gases will form at elevated temperatures (thermal decomposition). Toxic gases will form upon combustion.

FIRE FIGHTING: Use water spray to cool fire exposed surfaces and to protect personnel. Shut off fuel to fire.

Use foam, dry chemical or water spray to extinguish fire. Respiratory and eye protection required for fire fighting personnel. Avoid spraying water directly into storage containers due to danger of boilover. A self-contained breathing apparatus (SCBA) should be used for all indoor fires and any significant outdoor fires. For small outdoor fires, which may easily be extinguished with a portable fire extinguisher, use of an SCBA may not be required.

HAZARDOUS COMBUSTION PRODUCTS: Smoke, carbon monoxide, carbon dioxide and traces of oxides of sulphur. Alkyl mercaptans and sulfides may also be released.

8. REACTIVITY DATA

STABILITY: This product is stable. Hazardous polymerization will not occur.
 INCOMPATIBLE MATERIALS AND CONDITIONS TO AVOID: Strong oxidizing agents.
 HAZARDOUS DECOMPOSITION: Smoke, carbon monoxide, carbon dioxide, oxides of sulphur and phosphorus. Alkyl mercaptans and sulfides may also be released.

9. NOTES

This MSDS has been revised in Section 3.

10. PREPARATION

Date Prepared:	February 02, 1996
Prepared by:	Lubricants & Specialties IMPERIAL OIL Products Division 111 St. Clair Ave., West Toronto, Ontario M5W 1K3 800-268-3183

CAUTION: "The information contained herein relates only to this product or material and may not be valid when used in combination with any other product or material or in any process. If the product is not to be used for a purpose or under conditions which are normal or reasonably foreseeable, this information cannot be relied upon as complete or applicable. For greater certainty, uses other than those described in Section 1 must be reviewed with the supplier. The information contained herein is based on the information available at the indicated date of preparation. This MSDS is for the use of Imperial Oil. Customers and their employees and agents only. Any further distribution of this MSDS by Imperial Oil customer is prohibited without the written consent of Imperial Oil."

IMPERIAL OIL
Products Division

ESSO GEAR OIL GX 80W-90

SWR • SWC • SWD OPERATOR INSTALLATION GUIDE



MATERIAL SAFETY DATA SHEET

Product Name: Sealed Maintenance Free Lead-Acid Batteries

DATE:	9/23/2002	ISSUED BY:	ENGINEERING	TELEPHONE NO.:	(619) 661-2030
HAZARDOUS COMPONENTS					
COMPONENTS	WEIGHT %	TLV	LD50	LC50	LC50
Lead (Pb, PbO ₂ , PbSO ₄)	about 70%	N/A	(500) mg/kg	N/A	N/A
Sulfuric Acid	about 20%	1mg/m ³	(2,140) mg/kg	N/A	N/A
Fiberglass Separator	about 5%	N/A	N/A	N/A	N/A
ABS Plastic	about 5%	N/A	N/A	N/A	N/A

PHYSICAL DATA

COMPONENTS	DENSITY	MELTING POINTS	SOLUBILITY (H ₂ O)	ODOR	APPEARANCE
Lead	11.34	327.4° C (Boiling)	None	None	Silver-Gray Metal
Lead Sulfate	6.2	1070° C (Boiling)	40 mg/(l.5° C)	None	White Powder
Lead Dioxide	9.4	290° C (Boiling)	None	None	Brown Powder
Sulfuric Acid	about 1.3	about 114° C (Boiling)	100%	Acidic	Clear Colorless Liquid
Fiberglass Separator	N/A	N/A	Slight	Toxic	White Fibrous Glass
ABS Plastic	N/A	N/A	None	No Odor	Solid

FLAMMABILITY DATA

COMPONENTS	FLASHPOINT	EXPLOSIVE LIMIT	COMMENTS
Lead	None	None	
Sulfuric Acid	None	None	
Hydrogen		4% - 72.4%	Sealed batteries can emit hydrogen if over charged (float voltage > 2.40 VPC).
Fiberglass Separator	N/A	N/A	Toxic vapors may be released. In case of fire, wear self-contained breathing apparatus.
ABS Plastic	None	N/A	Temp. over 300° C (572° F) may release combustible gases. In case of fire, wear positive pressure self-contained breathing apparatus.

FIRST AID

SULFURIC ACID PRECAUTIONS

Skin Contact:	Flush with water; see physician if contact area is large or if blisters form.
Eye Contact:	Call physician immediately and flush with water until physician arrives.
Ingestion:	Call physician. If patient is conscious, flush mouth with water; have patient drink milk or sodium bicarbonate solution.

REACTIVITY DATA

COMPONENT STABILITY	Sulfuric Acid Stable at all temperatures
CODYMERIZATION	Will not polymerize
INCOMPATIBILITY	Reactive metals, strong bases, most organic compounds
DECOMPOSITION PRODUCTS	Sulfuric dioxide, trioxide, hydrogen sulfide, hydrogen
CONDITIONS TO AVOID	Prohibit smoking, sparks, etc. from battery charging area. Avoid mixing acid with other chemicals

SPILL OR LEAK PROCEDURES

Steps to take in case of leak or spill:	If sulfuric acid is spilled from a battery, neutralize acid with bicarbonate (baking soda), sodium carbonate (soda ash), or calcium oxide (lime). Flush area with water and discard to the sewage system. Do not allow unneutralized acid into sewage system.
Waste disposal method:	Neutralized acid may be flushed down the sewer. Spent batteries must be treated as hazardous waste and disposed of according to local, state, and federal guidelines. A copy of this MSDS must be supplied to any scrap dealer or secondary lead smelter with battery.

PROTECTION

EXPOSURE SITE	PROTECTION	COMMENTS
SKIN	Rubber gloves, Apron	Protective equipment must be worn if the battery is cracked or otherwise damaged. A respirator should be worn during reclaim operations if the TLV is exceeded.
RESPIRATORY	Respirator (for lead)	
EYES	Safety goggles, Face Shield	

ELECTRICAL SAFETY

Due to the battery's low internal resistance and high power density, high levels of short circuit current can be developed across the battery terminals. Do not rest tools or cables on the battery. Use insulated tools only. Follow all installation instructions and diagrams when installing or maintaining battery systems.

HEALTH HAZARD DATA

LEAD: The toxic effects of lead are accumulative and slow to appear. It affects the kidneys, reproductive, and central nervous systems. The symptoms of lead overexposure are anemina, vomiting, headache, stomach pain (lead colic), dizziness, loss of appetite, and muscle and joint pain. Exposure to lead from a battery most often occurs during lead reclaim operations through the breathing or ingestion of lead dust or fumes.

SULFURIC ACID: Sulfuric acid is a strong corrosive. Contact with acid can cause severe burns on the skin and in eyes. Ingestion of sulfuric acid will cause GI tract burns. Acid can be released if the battery case is damaged or if vents are tampered with.

FIBERGLASS SEPARATOR: Fibrous glass is an irritant of the upper respiratory tract, skin and eyes. For exposure up to 100°F/C use MSA Combil with type H filter. Above 100°F/C use Ultra-Twin with type H filter. This product is not considered carcinogenic by NTP or OSHA.

ALL DATA MUST BE PASSED TO ANY SCRAP DEALER OR SMELTER WHEN BATTERY IS RESOLD.

SWR • SWC • SWD OPERATOR INSTALLATION GUIDE

PREVENTATIVE MAINTENANCE

IMPORTANT!

- Always disconnect power from operator before servicing.
- Keep clear of gate during operation.

GENERAL:

OSCO gate operators are designed for many years of trouble-free operation and, under recommended operating conditions, will require only minimal maintenance. To ensure that your unit is ready for operation at all times--and to preclude serious damage or failure--inspect the unit systematically. Proper adjustments and lubrication should be made as recommended.

LUBRICATION:

Bearings. For models which have pillow block style bearings with greaseable fittings, lubricate at least twice a year with a lithium complex based, petroleum oil NLGI 2 rated grease. Oilite and precision sealed bearings do not require additional lubrication.

Motor. Motors have sealed ball bearings and do not require further lubrication. If bearing noise develops after several years of operation, bearings should be replaced by a motor repair company, or the motor should be replaced if necessary.

Drive Chain and Sprocket (slide gate models only). The main drive chain and sprockets should be inspected for wear, cleaned, and wiped down with a lightly oiled rag every six months.

Swing Gate Arm (swing gate models only). Check all bolts for proper tension and tighten if necessary. Make sure the arm folds overextends itself slightly against the overtravel stop to reduce the chance that the gate can be backdriven open. Adjust the close limit slightly if additional travel is required. Lightly lubricate all pivot points with a light machine oil.

Barrier Gate Arm (barrier gate models only). Check all bolts for proper tension and tighten if necessary. If the arm has been warped or damaged, replace as necessary.

ADDITIONAL SIX MONTH PREVENTATIVE MAINTENANCE:

1. For operators which utilize torque limiting clutches, check for proper tightness. If there appears to be dust from wear on the pads, inspect the pads and replace if necessary. If the clutch cannot be adjusted tightly enough to move the gate without slipping, the pads must be replaced.
2. For operators with V-belts, inspect for wear and replace as necessary. Check for proper tension and adjust if required. Check all pulley setscrews for tightness and tighten if necessary.
3. For operators with internal chain drives, inspect chain and sprockets for wear and replace if necessary. Check for proper tension and alignment, and adjust if required. Check all hub sprocket setscrews and tighten if required.
4. Check limit switches and limit actuators (cams, limit nuts, etc.) for wear and replace as required. In rotary limit switch assemblies, wipe the limit shaft clean and apply a light coating of dry lubricant.
5. For operators with magnetic brakes, check for proper adjustment. Brake disc must run free when the brake is engaged. For brake assemblies other than C-face style, the brake should be adjusted so that the solenoid plunger throw is between 3/8" to 1/2". Too much throw will damage the solenoid. **If the solenoid emits a loud buzzing sound when the motor is run, the brake must be adjusted.**
6. In operators which have a disconnect handle, inspect disconnect handle for proper function and lubricate if necessary. Use a lithium based grease on all moving parts.
7. Inspect all nuts and bolts for proper tightness and tighten as necessary.
8. Check all reversing devices for proper function. Inspect all contact edges for wear and replace if required. Check photoeyes for proper alignment and function.
9. Check current sensing for proper adjustment when finished with inspection and maintenance.
10. Inspect the installation area. Are all the warning signs intact and visible? If they are missing or need replaced, contact OSCO. Be sure there are no control stations mounted within reach of the gate. Review safety literature with the customer and advise them to remove any such stations found.

For slide and swing gate operators, you must inspect the gate for proper operation. The gate should move easily without binding through its entire travel. If the gate does bind, adjust or fix as required. Failure to keep the gate in good working condition will have adverse effects on the operator.

SWR • SWC • SWD OPERATOR INSTALLATION GUIDE

GATE OPERATOR INSTALLATION CHECKLIST

INSTALLER	CUSTOMER	
_____	_____	1. The gate has been checked to make sure it is level and moves freely in both directions.
_____	_____	2. Potential pinch areas have been guarded so as to be inaccessible OR have contact and/or non-contact obstruction sensing devices installed.
_____	_____	3. The installer has installed one or more contact or non-contact obstruction sensing devices, in compliance with UL325 requirements for this installation.
_____	_____	4. If pedestrian traffic is expected, a separate pedestrian gate has been installed, a minimum of seven feet from the gate. The customer has been informed that <u>all pedestrian traffic must use the pedestrian gate.</u>
_____	_____	5. Warning signs have been installed on each side of the gate in highly visible locations. The customer has been informed that these signs must remain at all times.
_____	_____	6. There are no controls installed on the gate operator, or within seven feet of the gate.
_____	_____	7. The installer has properly adjusted the obstruction sensing feature and has tested the gate to make sure that the gate stops and reverses a short distance with minimal resistance applied (40 lbs. on a swing gate at the end of the gate, 75 lbs. on a slide gate)
_____	_____	8. The installer has instructed the customer in the proper use of the gate operator and reviewed all of the operational functions, obstruction sensing devices, warning beeper and reset, etc.
_____	_____	9. The installer has instructed the customer in the proper use of the operator's manual disconnect feature. The manual disconnect must never be used while the gate is in motion. The power switch must be turned off before using the manual disconnect and disengaging the operator.
_____	_____	10. The installer has reviewed all safety instructions with the customer, and has left the safety instructions and owner's information sheets for their reference.
_____	_____	11. The installer has answered any questions the customer has regarding the operation of the gate operator and gate operator safety precautions.
_____	_____	12. The installer has explained to the customer that a regular maintenance schedule for both the gate and the gate operator is recommended.

By signing this installation checklist, I/we hereby certify that each item listed and checked above has been covered by the installer and is clearly understood by the customer.

Customer Signature

Date

Installer Signature

Date