

RESIDENTIAL

**DOUBLE GATE LATCH\***

Fits 1 3/8" frame  
Adjusts for 2" - 4" gap.

No. 4138

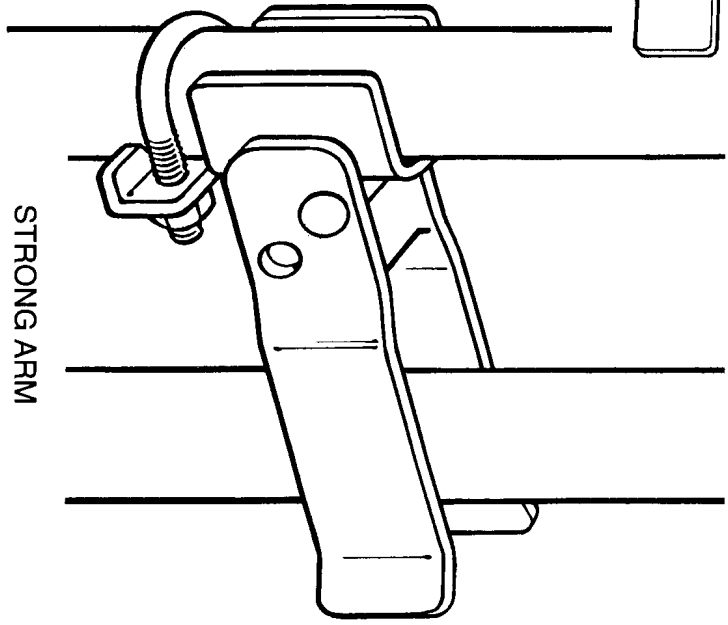

STRONG ARM

**WALK GATE LATCH**

Fits 1 5/8" or 2" frame  
Allows for 2" to 5" gap.

- No. 4250 . . . 2 1/2" Latch Post
- No. 4300 . . . .3" Latch Post
- No. 4400 . . . .4" Latch Post

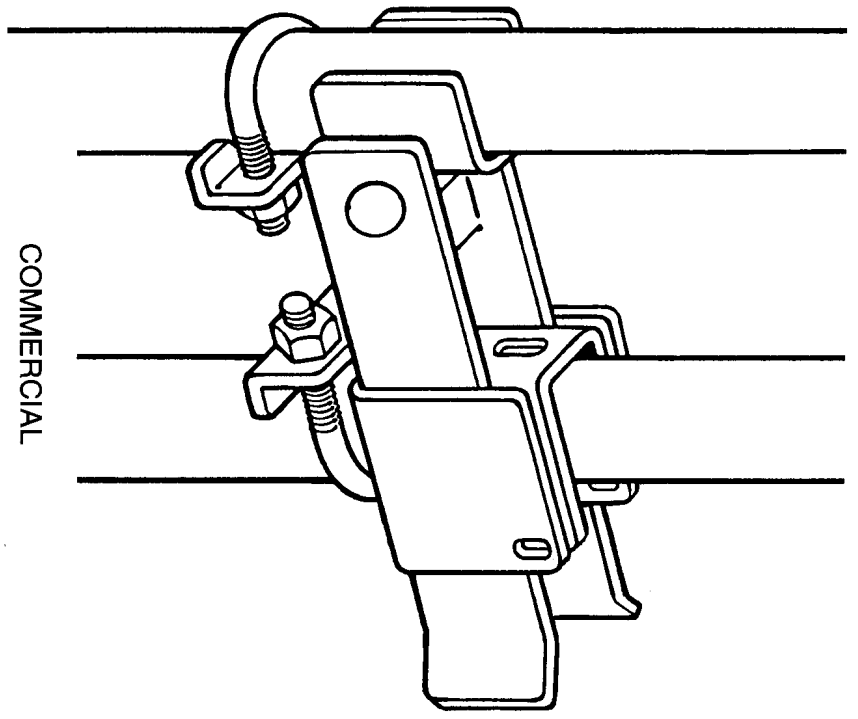

COMMERCIAL

**DOUBLE GATE LATCH\***

Fits 1 5/8" or 2" frame  
Adjusts for 2" - 6" gap.

No. 4000

\*DROP ROD NOT REQUIRED

LOCKABLE

GALVANIZED

**STRONG ARM LATCH**

JOB / PROJECT

DATE



1-800-888-9768  
www.dacindustries.com

OF