

ASSEMBLY INSTRUCTIONS

New England[®]
Arbors
Leadership by Design

The 5x5 Professional Post Extension Kit

(Designed to be used with any New England Arbor with 5x5 Posts)

Please read through before starting assembly.

Check Box for These Contents

In the event of missing or defective parts please call our customer service dept. at **1 800 282 9346** (Mon. to Fri. 8:00 AM to 4:00 PM EST)

1. 5 x 5 x 30" Post Extensions (4)
2. #8 x 1 1/2" Stainless Steel Screws (32)
3. Vinyl Weld (1)

Tools You Will Need

- Cordless Drill

General Information

- **Read Instructions through carefully before beginning assembly.**
- When assembling components, place on a non-abrasive surface (i.e. shipping box) to avoid scratching.
- We recommend an area approx 5'x 8' for unobstructed assembling.
- You should not need to use excessive force when assembling components.

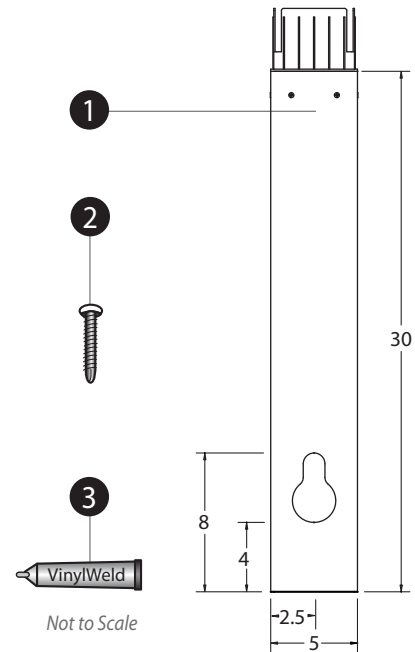

STEP ONE

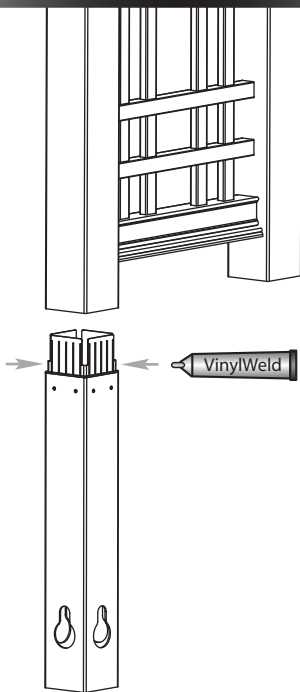

Glue all four sides of the joiner

STEP TWO

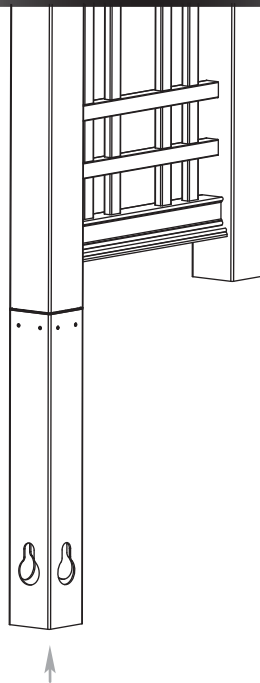

Slide the joiner of the 5x5 extension into the arbor posts.

STEP THREE

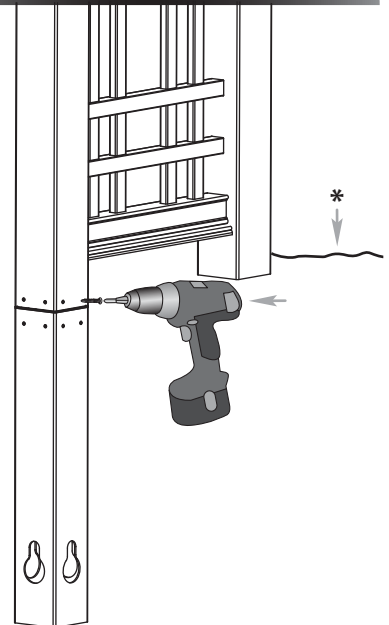

Screw all four sides of the arbor posts with 2 screws per side (repeat for all posts).

**Once arbor installation is complete, the extension joint should be buried 1" to 3" (depending on the arbor it is being used with), below earth grade.*