

SLIMSTONE

STRONG, FROST-FREE AND WATERTIGHT KEYPAD

LOCINOX

Let's make better fences together



The SlimStone keypad with integrated LED lighting is unique in its kind thanks to its strength. The keypad was developed and tested for use in the most extreme weather conditions to guarantee access control in all circumstances. Assembly and mounting are very easy.



QUICK-FIX

STAINLESS
STEEL

1.000.000
TESTED

2 YEAR
WARRANTY

- ✓ DURABLE & ELEGANT DESIGN
- ✓ EXCELLENT QUALITY
- ✓ ENERGY EFFICIENT
- ✓ EXTREME WEATHER PROOF
- ✓ FROST-FREE
- ✓ EASY & FAST INSTALLATION



Modularity



Ease of Installation



Trusted Quality



Full Support

TECHNICAL INFORMATION ON REVERSE SIDE 

TECHNICAL DRAWINGS

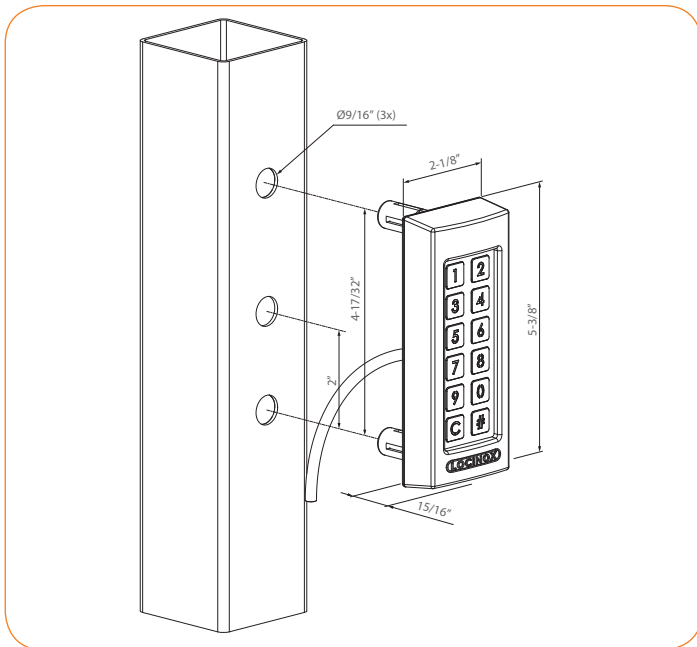

CHARACTERISTICS

- Available in two colours :
ZILV 9005
- Stainless steel front plate and keys
- Aluminium housing resistant to vandalism with structured free from scratches lacquer
- Led lighting under keys
- Easy programming of up to 100 codes
- Remote disconnection through relay contact
- Push buttons tested with over 1,000,000 pushes
- Tested from -22 up to +185° Farenheit
- Including Quick-Fix and fixing for wood and stone

TECHNICAL INFORMATION

- 6.56 ft connection cable included
- Easy installation and connection thanks to integrated relay (1x NC and 1x NO contact)
- Working voltage keypad from 10 up to 26 Volt AC/DC
- Current: 1.0 A (with heating) / Power P= 24W (with heating)
- Switching relay: 1 x NO - 1 x NC - 1 x COM (Max. 2A, 60W, 26V AC/DC)



ALL-IN-ONE MODULEC KIT
Set with Modulec SA or SH keep,
SlimStone keypad and power supply

