

## FLEX MOUNT KIT INSTALLATION INSTRUCTIONS FMK-SW (Swing Gates) & FMK-SL (Sliding Gates)

### 1. INTRODUCTION

Securitron's flex mount bracket system is used for installation of either an M62F, M62FG (with or without the SASM kit) or GL1 on most round or square post fences and gates (for square post applications an extra shim pack is needed), separate versions are available for swinging or sliding applications. The flex mount design allows for complete adjustment to fit most any installation, with the ease of bolt-on weld-able steel brackets for complete security.

**Note:** Brackets are numbered for ease of identification.

**Note:** For Security purposes it is recommended to weld all brackets and hardware to ensure a secure installation.

### 2. RECOMMENDED TOOLS

Electric Drill  
 Adjustable Wrench  
 Hammer

3/16" Hex Wrench  
 1/4"-20 Tap  
 Welder (optional)

5/16", 13/16" & 3/8" Drill Bits  
 7/16" Socket Wrench

### 3. PRODUCT OVERVIEW

Upon unpacking this product, an inventory should be made to ensure that all the required components and hardware have been included. Along with these instructions each product should include the following items.

FASTENER	QTY	DESCRIPTION
SA	1	5/16-18 X 1 1/4 FH SCREW
SB	8	1/4-20 X 3/4" CAP SCREW
SC	6	1/4-20 X 1/2" HEX BOLT
SD	1	5/16-18 LOCK NUT
SE	4	1/4-20 LOCK NUT
SF	4	1/4-20 X 1-3/4" CAP SCREW
SG	2	1/4-20 X 2-3/4" HEX BOLT
SH	2	1/4-20 X 3-3/4" HEX BOLT
SJ	6	1/4" SPLIT WASHER

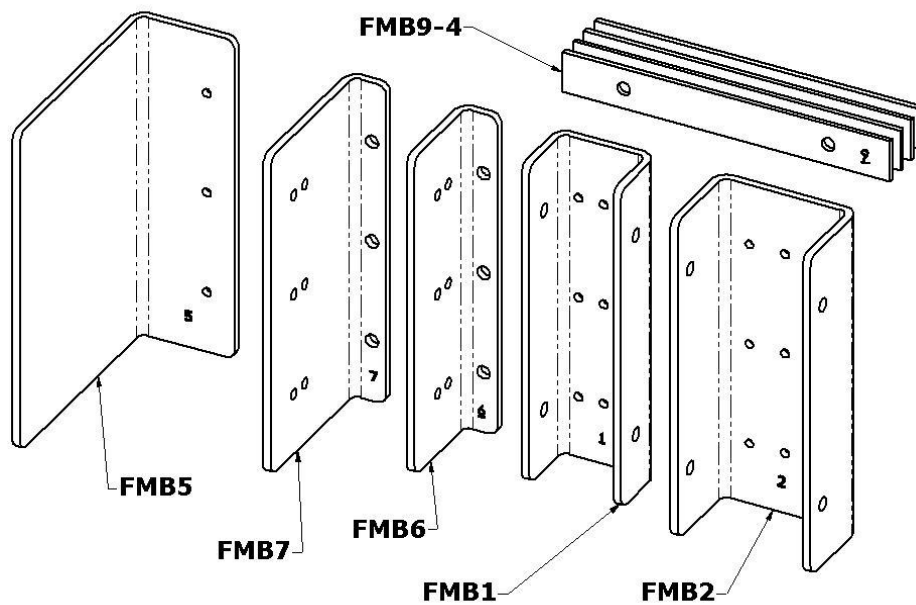

**FMK-SW - Swing Gate Kit**

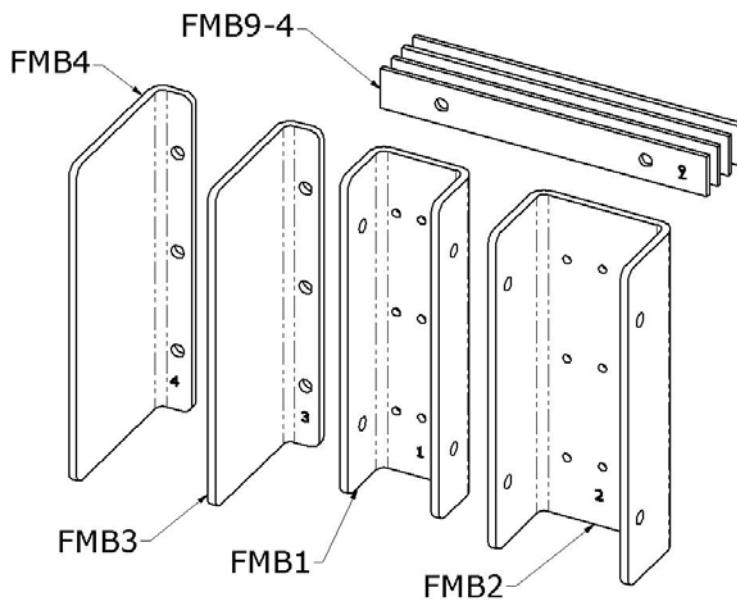

### FMK-SL – Slide Gate Kit

## 4. SWINGING GATES - INSTALLATION INSTRUCTIONS

### 4.1 Pre-Installation Survey

It is recommended that an initial on sight survey be performed. A method of mounting should be determined and an installation plan should be reviewed as follows:

- Physical strength of mounting areas should be strong enough to meet or exceed the holding force of the required Magnalock.
- Placement of the Magnalock wiring and protection from potential damage due to intruders or vandals external attack should be considered during the survey.
- Accessibility should be considered for prevention of any potential safety hazard.

### 4.2 Swinging Gate Applications

#### 4.2.1 Installing the lock "U" Bracket (#2) to the fence post

The installation must be planned before you start drilling. The bracket must first be positioned on the fence post (see **FIG 1**) at a location suitable for lock height, Make sure there are no obstructions on either the fence or gate posts at this height, using the bracket as a template, carefully mark the four through hole locations onto the post.

Remove the bracket and carefully center punch and drill the four locations using a 5/16" drill bit, reinstall the bracket and install the shims and hardware as shown in **FIG 1**.

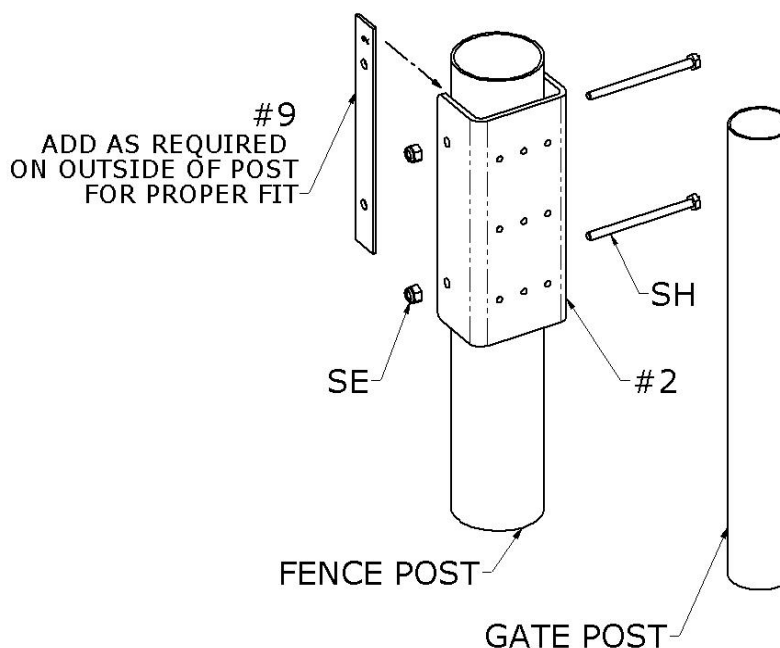
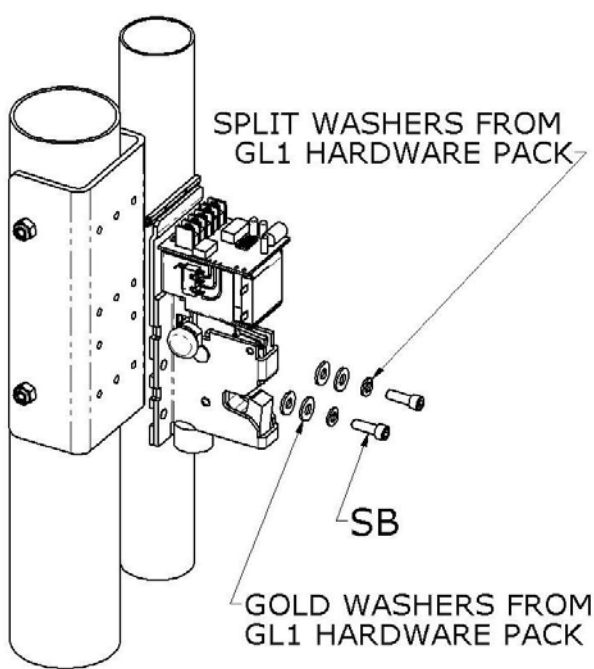

**FIG 1**

### 4.2.2 Installing the Lock

**GL1** - Position the lock template onto Bracket #2, align the lower holes of the template with the lowest holes in the bracket and mark the two upper holes for the GL1. Carefully center punch and drill the two new holes with a 13/64" bit and tap for 1/4-20 machine screws. Install the lock using the hardware as shown in **FIG 2A** . Install GL1 chassis with indicated hardware in the upper holes. Complete installation of the GL1 lock by referring to FIG 2A and following the installation guide included with the GL1.

**Magnalock**<sup>®</sup> - Position the lock template onto Bracket #2, mark only the four corner holes for the Magnalock. Carefully center punch and drill all four holes with a 13/64" bit and tap for 1/4-20 machine screws. Install the lock using the hardware as shown in **FIG 2B**. Complete installation of the Magnalock lock by referring to **FIG 2B** and following the installation guide included with the Magnalock.



**FIG 2A**

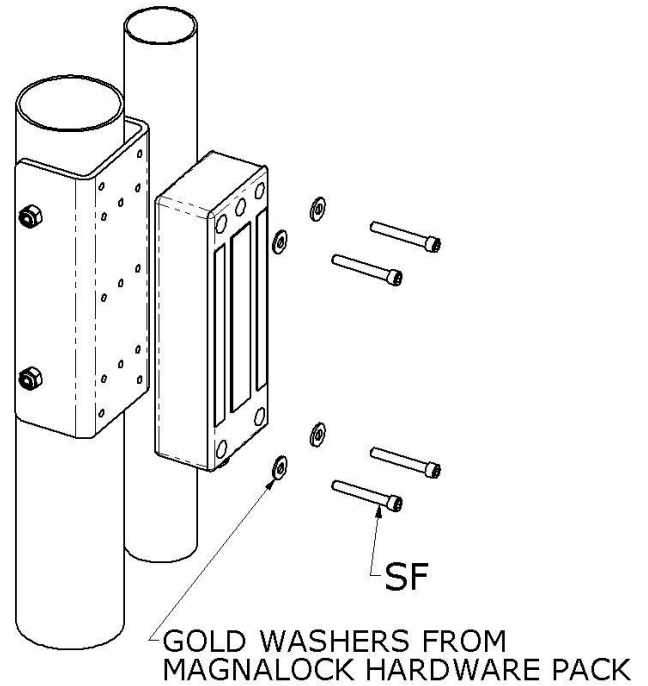
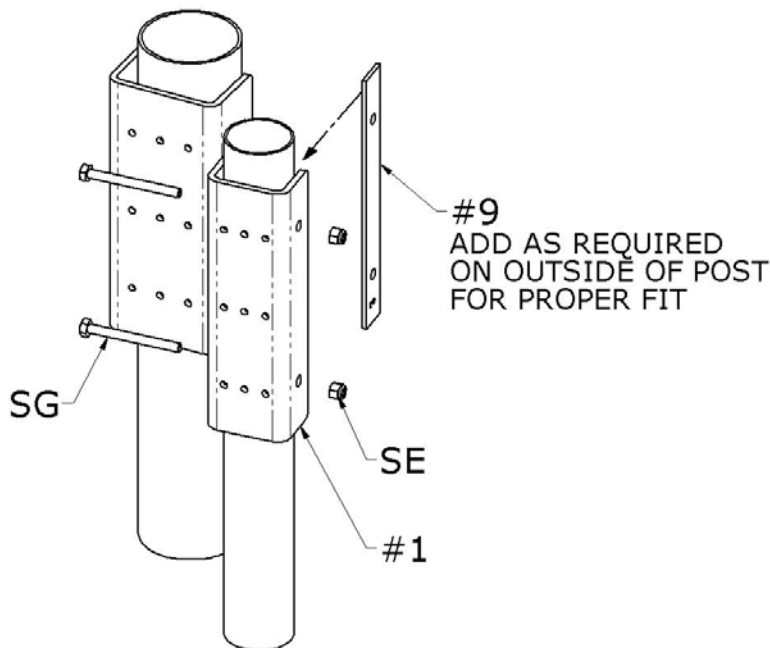

**FIG 2B**

### 4.2.3 Installing the GL1 strike "U" Bracket (#1) to the gate post

Close the gate and align the GL1 strike bracket on the fence post to match the position of the lock bracket as shown in **FIG 3**, using the bracket as a template, carefully mark the four through-hole locations onto the post.

Remove the bracket and carefully center punch and drill the four locations using a 5/16" bit, reinstall the bracket and install the shims and hardware as shown in **FIG 3**.



**FIG 3**

#### 4.2.4 Installing the adjustable Z-Bracket assembly

Select the appropriate "L" bracket for your application (#6 for Magnalocks, #7 for GL1 or Magnalock with SASM) adjust and install bracket #5 as shown in FIG 4A & 4B, adjust and install completed Z-Bracket as shown in FIG 4A & 4B. Note: Brackets can be adjusted in any manner necessary to cover the lock area as shown in FIG 4A & 4B.

#### 4.2.5 Installing the strike assembly to the Z-Bracket

Position the strike to the lock, ensure it is aligned properly with the lock (you can energize the Magnalock to hold the strike or insert the GL1 strike into the latch for ease of alignment) carefully close the gate and Z-Bracket until it touches the strike. Mark the outer edge outline of the strike, open the gate and position the strike template in the outlined area. Mark the mounting and roll pin hole locations as needed, center punch and drill appropriate holes (13/64" drill bit and 1/4-20 tap for GL1 strike, or 5/16" drill bit for Magnalock strike center hole and roll pins, attach as shown in FIG 4A & 4B.

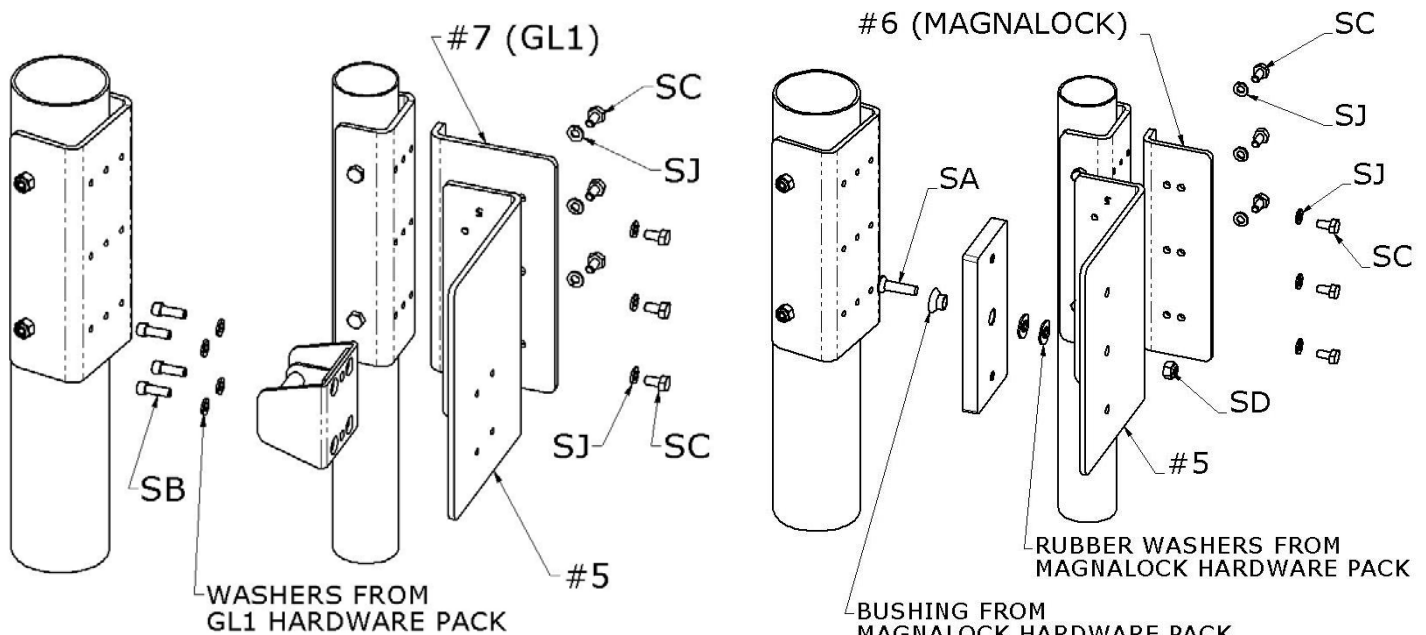

LOCK OMITTED FOR CLARITY

FIG 4A

LOCK OMITTED FOR CLARITY

FIG 4B

### 5. SLIDING GATES - INSTALLATION INSTRUCTIONS

#### 5.1 Pre-Installation Survey

It is recommended that an initial on sight survey be performed. A method of mounting should be determined and an installation plan should be reviewed as follows:

- Physical strength of mounting areas should be strong enough to meet or exceed the holding force of the required Magnalock.
- Placement of the Magnalock wiring and protection from potential damage due to intruders or vandals external attack should be considered during the survey.
- Accessibility should be considered for prevention of any potential safety hazard.

#### 5.2 Sliding Gate Applications

##### 5.2.1. Installing the lock "U" Bracket (#2) to the fence post

The installation must be planned before you start drilling. The bracket must first be positioned on the fence post (see FIG 5) at a location suitable for lock height, Make sure there are no obstructions on either the fence or gate posts at this height, using the bracket as a template, carefully mark the four through hole locations onto the post.

Remove the bracket and carefully center punch and drill the four locations using a 5/16" bit, reinstall the bracket and install the shims and hardware as shown in FIG 5.

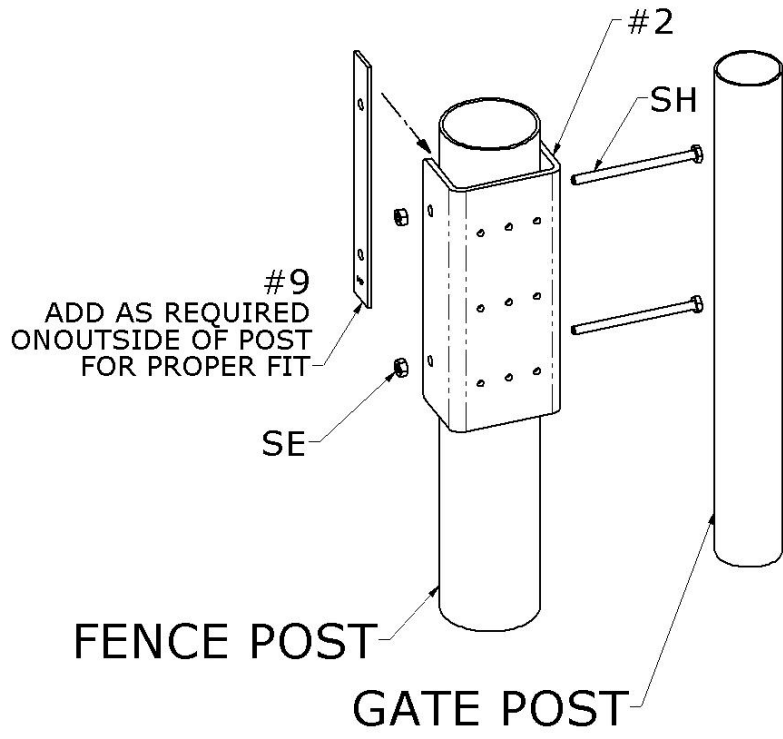

FIG 5

**5.2.2. Installing the lock "L" Bracket and lock**

Adjust the lock "L" bracket (#3) as shown in FIG 6, note: bracket #3 can be adjusted in any manner necessary to locate the lock as needed for proper gate closure.

**GL1** - Position the lock template onto Bracket #3, mark the four mounting holes for the GL1 and center wire feed hole if required. Carefully center punch and drill the four mounting holes with a 13/64" bit and tap for 1/4-20 machine screws. Install the lock using the hardware as shown in FIG 6A. Install GL1 chassis with indicated hardware in the upper holes. Complete installation of the GL1 lock by referring to FIG 6A and following the installation guide included with the GL1.

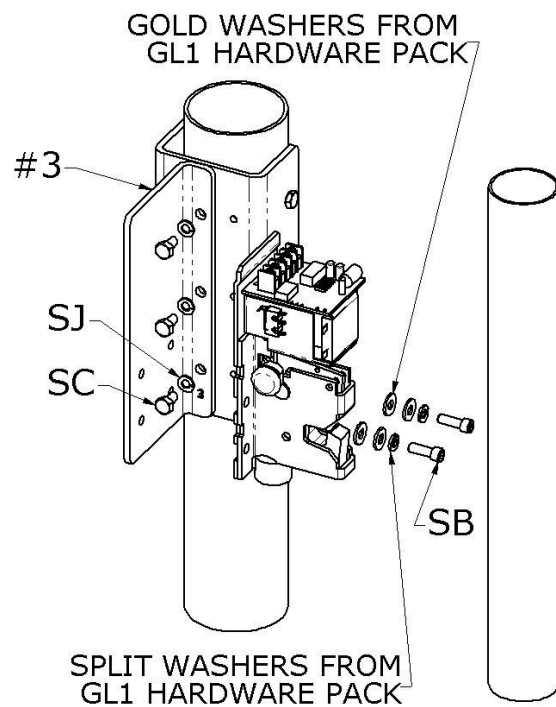
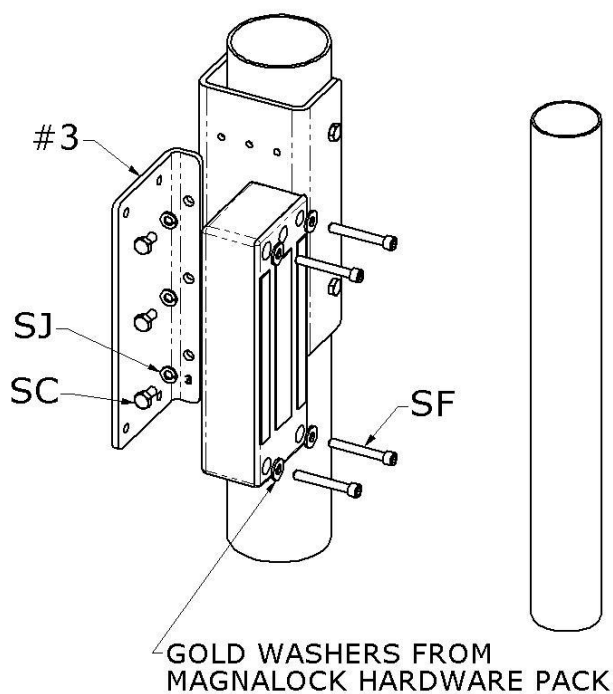

FIG 6A

**Magnalock®** - Position the lock template onto Bracket #3, mark only the four corner holes for the Magnalock. Carefully center punch and drill all four holes with a 13/64" bit and tap for 1/4-20 machine screws. Install the lock using the hardware as shown in FIG 6B. Complete installation of the Magnalock lock by referring to FIG 6B and following the installation guide included with the Magnalock.

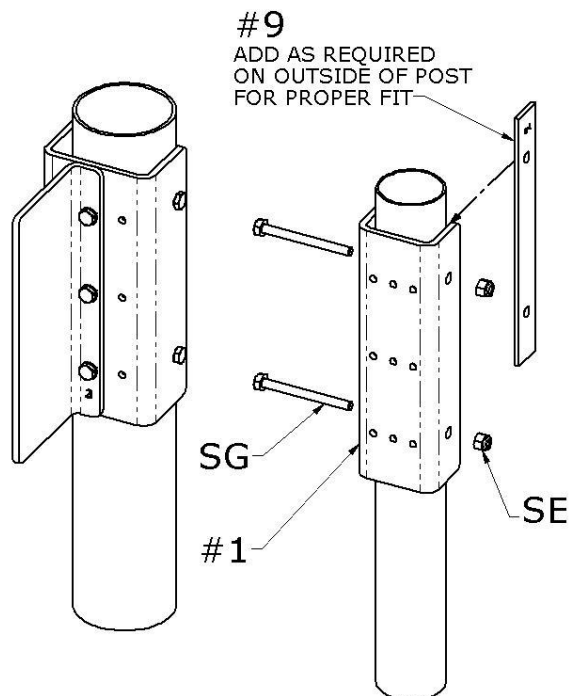

**FIG 6B**

### 5.2.3 Installing the strike "U" Bracket (#1) to the gate post

Close the gate and align the strike bracket on the fence post to match the position of the lock bracket as shown in **FIG 7**, using the bracket as a template, carefully mark the four through-hole locations onto the post.

Remove the bracket and carefully center punch and drill the four locations using a 5/16" bit, reinstall the bracket and install the shims and hardware as shown in **FIG 7**.



LOCK OMITTED FOR CLARITY

**FIG 7**

### 5.2.4 Installing the strike "L" Bracket and strike

Adjust the lock "L" bracket (#4) as shown in **FIG 8A & 8B**. NOTE: Bracket #4 can be adjusted in any manner necessary to locate the strike as needed for proper gate closure. Position the strike to the lock, ensure it is aligned properly with the lock (you can energize the Magnalock to hold the strike or insert the GL1 strike into the latch for ease of alignment) carefully close the gate and Z bracket until it touches the strike. Mark the outer edge outline of the strike, open the gate and position the strike template in the outlined area. Mark the mounting and roll pin hole locations as needed, center punch and drill appropriate holes (13/64" drill bit and 1/4-20 tap for GL1 strike, or 5/16" for Magnalock strike center hole and roll pins), attach as shown in **FIG 8A & 8B**.

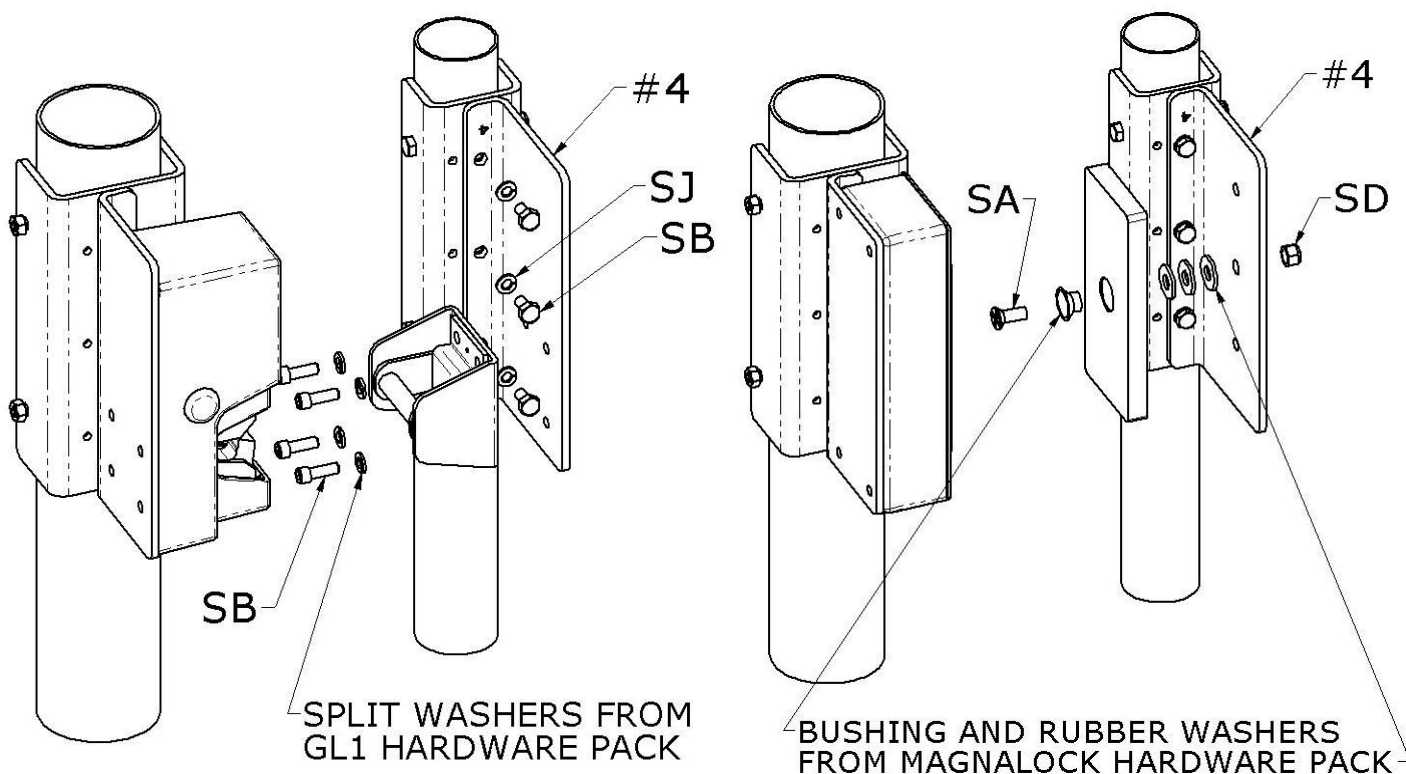

FIG 8A

FIG 8B

**MAGNACARE® LIMITED LIFETIME WARRANTY**

SECURITRON MAGNALOCK CORPORATION warrants that it will replace at customer's request, at any time for any reason, products manufactured and branded by SECURITRON since January 1, 1999.

SECURITRON will use its best efforts to ship a replacement product by next day air freight at no cost to the customer within 24 hours of SECURITRON's receipt of the product from customer. If the customer has an account with SECURITRON or a valid credit card, the customer may order an advance replacement product, whereby SECURITRON will charge the customer's account for the price of the product plus next day air freight, and will credit back to the customer the full amount of the charge, including outbound freight, upon SECURITRON's receipt of the original product from the customer.

SECURITRON's sole and exclusive liability, and customer's sole remedy, is limited to the replacement of the SECURITRON product when delivered to SECURITRON's facility (freight and insurance charges prepaid by customer). The replacement, at SECURITRON's sole option, may be the identical item or a newer unit which serves as a functional replacement. In the event that the product type has become obsolete in SECURITRON's product line, this MAGNACARE warranty will not apply. This MAGNACARE warranty also does not apply to custom, built to order, or non-catalog items, items made by others (such as batteries), returns for payment, distributor stock reductions, returns seeking replacement with anything other than the identical product, or products installed outside of the United States or Canada. This MAGNACARE warranty also does not apply to removal or installation costs.

SECURITRON will not be liable to the purchaser, the customer or anyone else for incidental or consequential damages arising from any defect in, or malfunction of, its products. SECURITRON does not assume any responsibility for damage or injury to person or property due to improper care, storage, handling, abuse, misuse, or an act of God.

EXCEPT AS STATED ABOVE, SECURITRON MAKES NO WARRANTIES, EITHER EXPRESS OR IMPLIED, AS TO ANY MATTER WHATSOEVER, INCLUDING WITHOUT LIMITATION THE CONDITION OF ITS PRODUCTS, THEIR MERCHANTABILITY OR FITNESS FOR ANY PARTICULAR PURPOSE.