

# Before You Start ...

**IMPORTANT: Before you install the automatic gate lock be sure your gate is level, moves freely on hinges, and is free from binding and/or dragging.**

For the GTO Automatic Gate Lock work properly the gate must close firmly enough to properly engage the lock catch against the lock receiver. Achieving optimal closure may require slight adjustments to the gate opener settings.

Installing the lock with a **Mighty Mule** gate opener may require some slight changes to the stroke adjustment (see "Setting the Gate Closed Position" in your Mighty Mule Installation Manual for information on these adjustments).

Installing the lock with a **GTO/PRO** gate opener may require some slight changes to the stroke adjustment and/or changes to the obstruction sensitivity (see your gate GTO/PRO Installation Manual for information on these adjustments).

Be sure you have all the parts:

- A - Lock w/ 20' of low voltage wire
- B - Lock Receiver
- C - Clevis Pin
- D - Locking Cap
- E - Lock Board Battery Lead Wires
- F - White Wire (motor lead to lock board)
- G - Lock Control Board
- H - 2 Double Spade Connectors
- I - 6 Tywraps
- J - 3M Scotch Lock
- K - Manual Release Keys
- L - Lock Decal

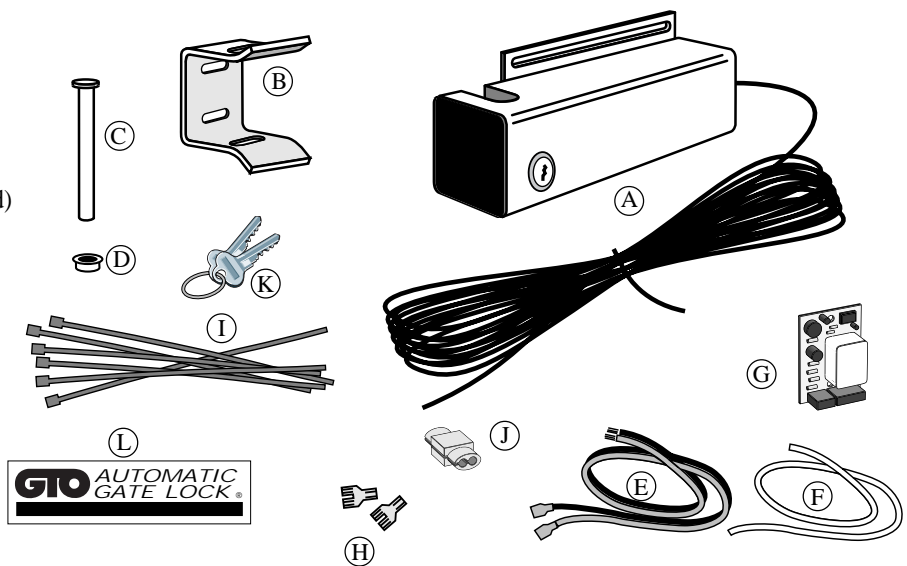

## What else do you need?

Check the following installation examples to determine the mounting hardware required for your application (not included).

**NOTE:** The GTO Lock is designed to use up to 5/16" diameter mounting hardware. For a more secure installation, we suggest you use lock washers and/or lock nuts on all mounting hardware.

For most **IRON or ALUMINUM TUBE** gates you will need:

Bolts, washers and nuts for the lock and receiver. (*see Illustration B, page 3*)

For most **CHAIN LINK** gates you will need:

U-Bolts and saddles or bolts, washers and nuts for the lock.

Bolts, washers and nuts for the receiver. (*see Illustration C, page 3*)

The installation has two parts ...

(1) Mounting The Lock and (2) Wiring It To The Operator Control Box

Once you have the necessary mounting hardware, you are ready to begin the installation.

# Mounting The Lock:

**Disconnect gate operator(s) from gate(s) by removing hair pin clip(s) and clevis pin(s) from the gate bracket end of the operator(s). This will allow gate(s) to swing freely during installation of gate lock.**

- Step 1:** With the gate in the closed position, determine the best location for the lock and receiver. The lock and receiver should be level and aligned with the operator arm. The lock should have a solid surface or cross member to provide stability.
- Step 2:** Hold or clamp receiver and lock together (with receiver pin hole and lock slot aligned) against the gate post and mark positions to drill receiver holes (*see Illustration B and C, page 3*). The receiver must be mounted with through bolts, not u-bolts, to allow lock to seat properly. Secure the receiver to the gate post.
- Step 3:** Recheck the lock position and alignment and mark position to drill holes on gate supports. U-bolts and saddles can be used to mount lock on chain link gate supports. Secure the lock to the gate. Install clevis pin and locking cap by placing clevis pin through slots in lock receiver and hammering the clevis pin into the locking cap (*see Illustration D*), and check the alignment again.

## Manual Lock Release:

The GTO Automatic Gate Lock has a **keyed manual lock release**. If the electronic lock release becomes disabled for any reason, simply use the key to manually open the lock.

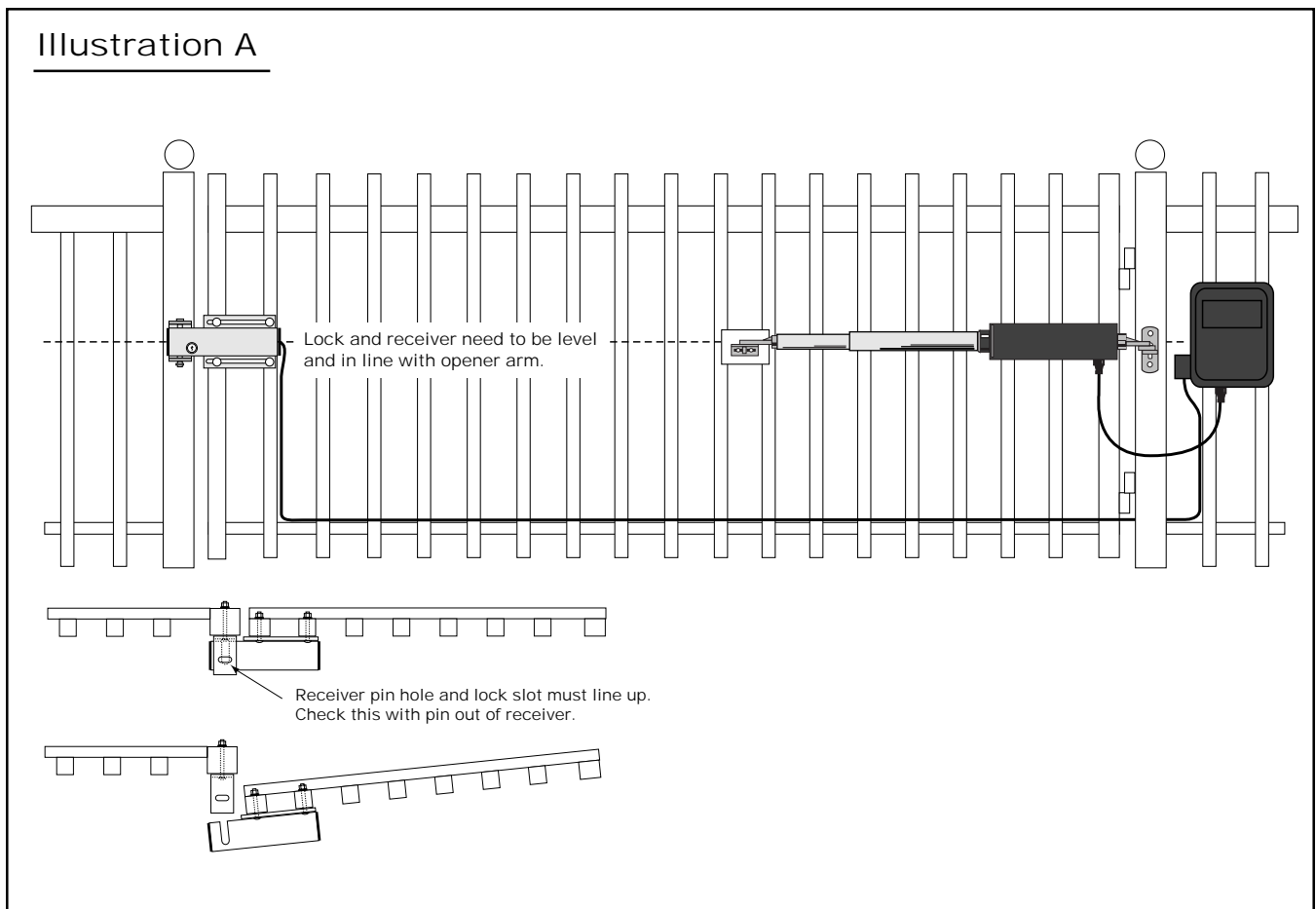

## Illustration B

### Iron or Aluminum Tube Fence and Gate Installation

Remember to check the alignment and mark positions before drilling holes in fence post and gate.

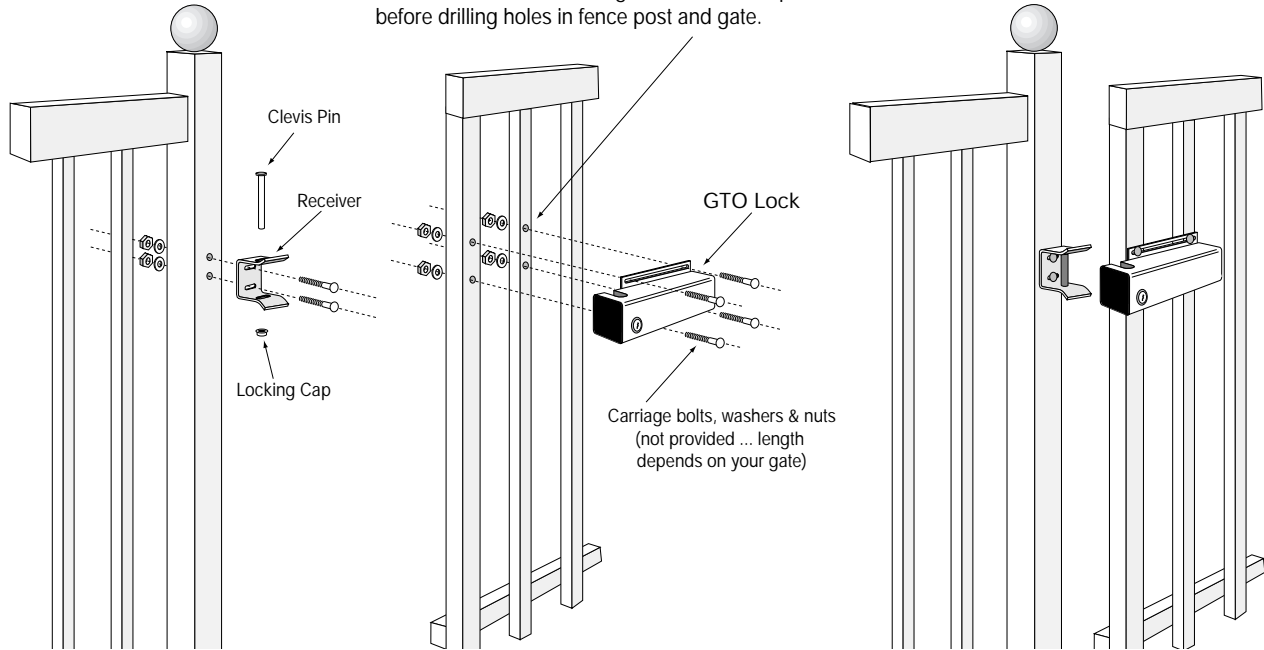

## Illustration C

### Chain Link Fence and Gate Installation

Remember to check the alignment and mark positions before drilling holes in fence post.

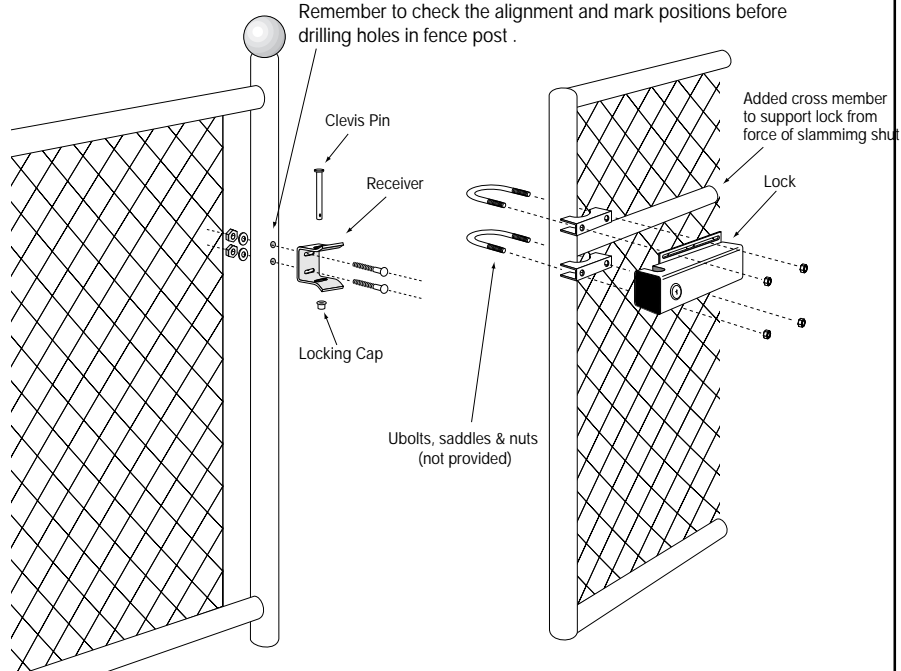

## Illustration D

### Locking Cap Assembly

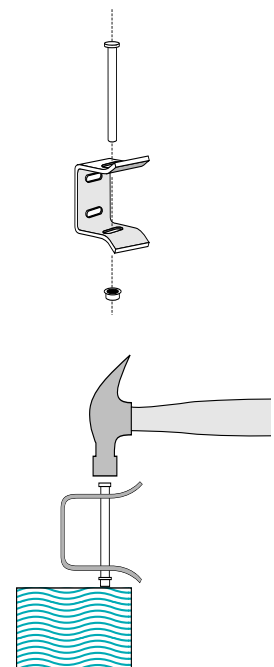

# Wiring the Control Box:

Refer to the appropriate diagram for your opener (on pages 5 & 6) and the Wiring Chart on this page as you follow these steps.

- Step 1.** Unplug the transformer and turn Control Box OFF. Then remove the control box cover and disconnect battery lead wires from battery terminals before beginning lock installation.
- Step 2.** Connect the **WHITE** wire (included) to Terminal #1 on the Lock Board. Connect the **RED** Battery Lead Wire (included) to Terminal #5 on the Lock Board. Connect the **BLACK** Battery Lead Wire (included) to Terminal #2 on the Lock Board. (See *Wiring Chart*). **Do not connect Lock Board Battery Lead Wires to battery until Step 6.**
- Step 3.** Attach the **RED** Control Board Battery Lead Wire to one spade on a Double Spade Connector (included). Attach the **BLACK** Control Board Battery Lead Wire to one spade on the other Double Spade Connector (included).
- Step 4.** Attach the 3M<sup>®</sup> Scotch Loc Connector. Place the **WHITE** wire from the Lock Board inside the “blocked” channel on the 3M<sup>®</sup> Scotch Loc Connector. If the gate opens into the property (Pull-to-Open), place the **BLACK** wire from the opener Power Cable inside the “through” channel on the 3M<sup>®</sup> Scotch Loc Connector. Crimp 3M Scotch Loc closed with pliers and fold plastic locking tab into place until it locks shut.
- NOTE:** If the gate(s) open away from the property (Push-to-Open) place the **RED** wire from the opener Power Cable inside the “through” channel on the 3M<sup>®</sup> Scotch Loc Connector. Crimp 3M Scotch Loc closed with pliers and fold plastic locking tab into place until it locks shut.
- If this is a dual gate installation use the **RED** (Push-to-Open) or **BLACK** (Pull-to-Open) wire that extends from the Power Cable leading to the opener arm *that is mounted on the same gate leaf that the lock is mounted to*. **This gate leaf must also be programmed to open first**; see your **GTO/PRO** Installation Manual for programming gate sequencing.
- Step 5.** Pull **RED** and **BLACK** wires from the Gate Lock through the strain relief and into the Control Box. Attach **BLACK** wire to Terminal #3 on Lock Board. Attach **RED** wire to Terminal #4 on Lock Board (*see Wiring Chart*).
- Step 6.** Attach **RED** Lock Board Battery Lead Wire to the Double Spade Connector with the **RED** Control Board Lead Wire. Attach the **BLACK** Lock Board Battery Lead Wire to the Double Spade Connector with the **BLACK** Control Board Lead Wire.
- Step 7.** Reconnect opener arm to gate bracket using clevis pin and hairpin clip. Connect **RED** wires (double spade connector) to **POSITIVE (+)** battery terminal and the **BLACK** wires (double spade connector) to the **NEGATIVE (-)** battery terminal. Plug the transformer back in and turn the Control Box power switch ON. Test opener and lock to make sure it is functioning properly and make adjustments if necessary.

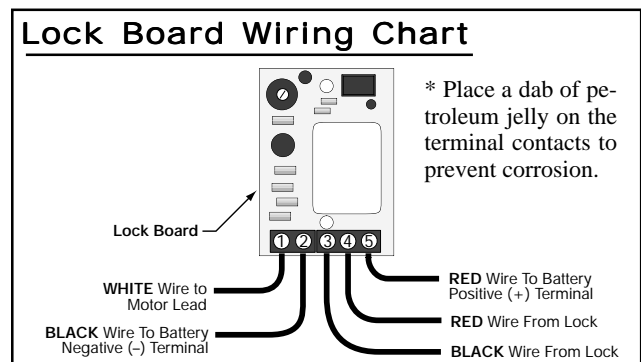

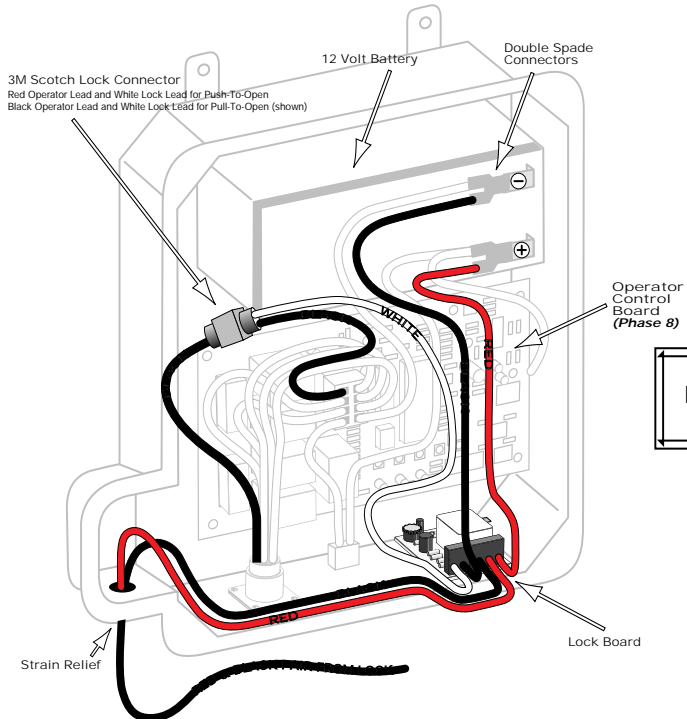
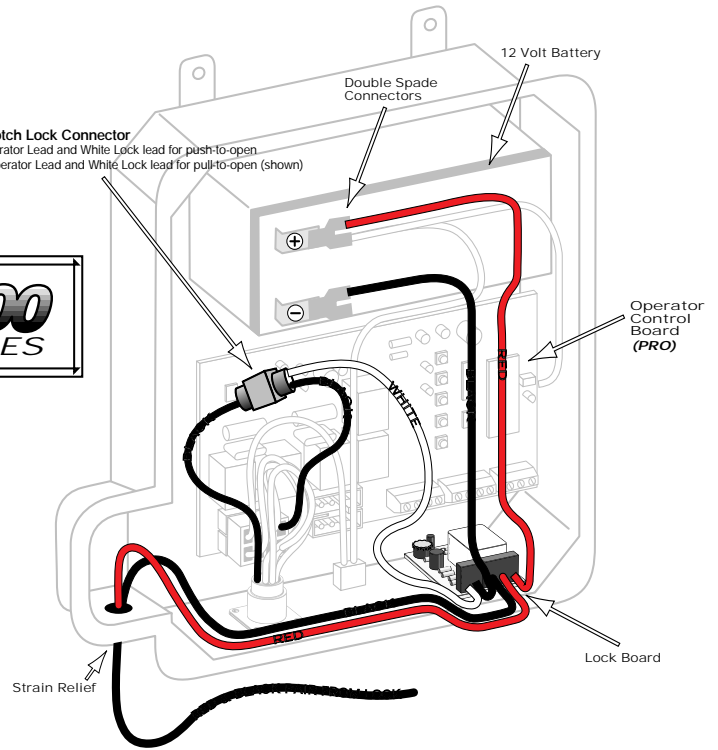
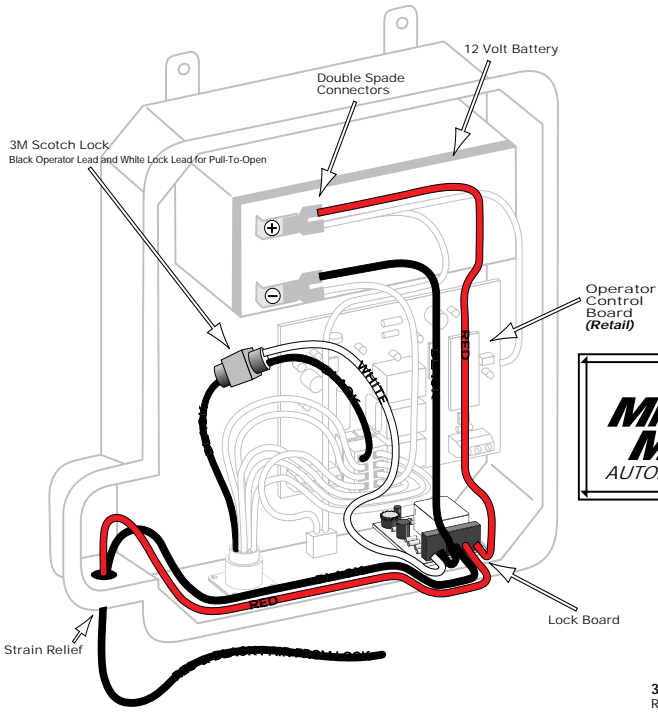

# GTO/PRO 2000

The 3M Scotch Lock Connector is not needed with the GTO/PRO 2000 control board. Connect the WHITE wire from the lock board directly to the operator terminal strip along with the power cable wire. Connect the WHITE wire to the BLACK terminal for Pull-to-Open installation (see illustration), connect WHITE to the RED terminal for Push-to-Open installation. Remaining wires are connected as described on page 4.

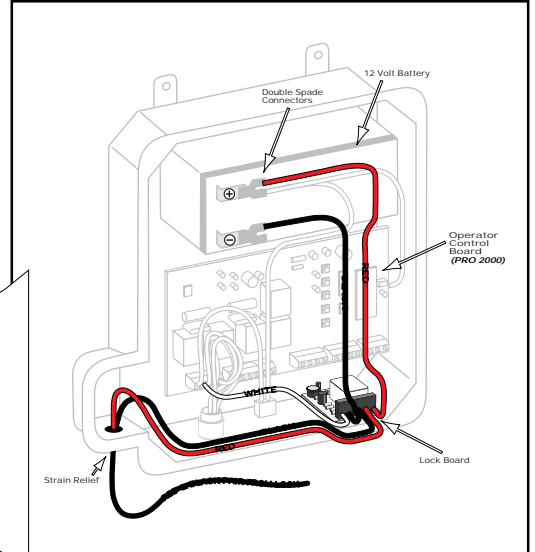
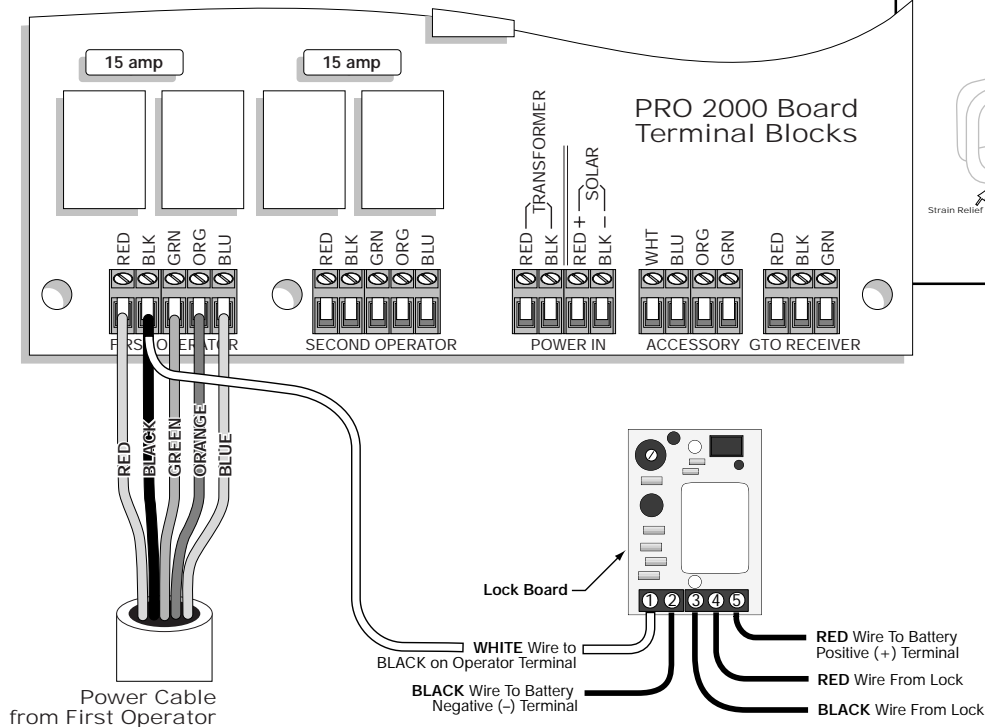

## Limited One Year Warranty:

GTO, Inc., gate operator accessories are warranted by the manufacturer against defects in workmanship for a period of one (1) year from the date of purchase, provided recommended installation procedures have been followed.

In the case of product failure due to defective material or manufacturer workmanship within the one (1) year warranty period, the accessory will be repaired or replaced (at the manufacturer's option) at no charge to the customer, if returned freight prepaid to GTO, Inc. 3121 Hartsfield Rd., Tallahassee, FL 32303.

**IMPORTANT:** Call (850)575-0176 or fax (850)575-8912 for a Return Goods Authorization (RGA) number before returning accessory to factory. Products received at the factory without an RGA will not be accepted. Replacement or repaired parts are covered by this warranty for the remainder of the one (1) year warranty period. GTO, Inc. will pay the shipping charges for return to the owner of items repaired under warranty.

The manufacturer will not be responsible for any charges or damages incurred in the removal of the defective parts for repair, or for the reinstallation of those parts after repair. This warranty shall be considered void if damage to the product(s) was due to improper installation or use, connection to an improper power source, or if damage was caused by lightning, wind, fire, flood, insects, or other natural agent.

After the one (1) year warranty period, GTO, Inc. or one of its authorized service centers will make any necessary repairs for a nominal fee. Call GTO at (850)575-0176 for more information. This warranty gives you specific legal rights, and you may also have other rights which may vary from state to state. This warranty is in lieu of all other warranties, expressed or implied. **NOTE:** Verification of the warranty period requires copies of receipts or other proof of purchase. Please retain those records.

**If you have any questions please call our customer service number:**

**(850)575-0176**

GTO, Inc. • 3121 Hartsfield Road • Tallahassee, Florida 32303 • (850)575-0176 • Fax (850)575-8912 • www.gtoinc.com

# **GTO** *AUTOMATIC GATE LOCK*®

## Installation Manual



**PLEASE NOTE** ... due to the various mounting applications, no mounting hardware is provided. All necessary mounting hardware can be obtained at your local hardware store; all other hardware is provided.

This manual gives a couple of the most common installation examples, and should provide insight into most other applications. If you have any questions during installation, please call (850)575-0176 for technical support.



**IMPORTANT:** For the optimum service and safety find the ideal obstruction-sensing setting for your gate operator. Depending on the weight of your gate the ideal setting will be just strong enough to move your gate without self-obstruction (stopping or reversing due to its own weight), but will be sensitive enough to reverse and/or stop when it meets with an obstruction such as a car or animal. See page 16 of the "GTO Installation Manual" for Obstruction Settings.

**NOTE:** Be sure your gate moves freely on hinges, free from binding and/or dragging.

**IMPORTANT:** For the optimum service and safety find the ideal obstruction-sensing setting for your gate operator. Depending on the weight of your gate the ideal setting will be just strong enough to move your gate without self-obstruction (stopping or reversing due to its own weight), but will be sensitive enough to reverse and/or stop when it meets with an obstruction such as a car or animal. See page 16 of the "GTO Installation Manual" for Obstruction Settings.

**NOTE:** Be sure your gate moves freely on hinges, free from binding and/or dragging.