

# Installation Manual for the

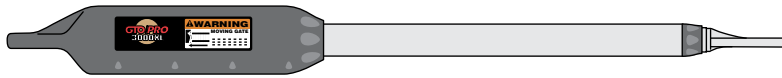

## **SINGLE Gate Operator System FOR PROFESSIONAL INSTALLATION ONLY!**

### **⚠ WARNING! ⚠**

This equipment is similar to other gate or door equipment and meets or exceeds Underwriters Laboratory Standard 325 (UL 325). However, gate equipment has hazards associated with its use and therefore by installing this product the installer and user accept full responsibility for following and noting the installation and safety instructions. Failure to follow installation and safety instructions can result in hazards developing due to improper assembly. You agree to properly install this product and that if you fail to do so GTO, Inc. shall in no event be liable for direct, indirect, incidental, special or consequential damages or loss of profits whether based in contract tort or any other legal theory during the course of the warranty or at any time thereafter. The installer and/or user agree to assume responsibility for all liability and use of this product releasing GTO, Inc. from any and all liability. If you are not in agreement with this disclaimer or do not feel capable of properly following all installation and safety instructions you may return this product for full replacement value.

**READ ALL INSTRUCTIONS CAREFULLY AND COMPLETELY** before attempting to install and use this automatic gate operator. This gate operator produces a high level of force. Stay clear of the unit while it is operating and exercise caution at all times.

All automatic gate operators are intended for use on vehicular gates only.

*This product meets and exceeds the requirements of UL 325, the standard which regulates gate operator safety, as established and made effective March 1, 2000, by Underwriters Laboratories Inc.*



For more information on GTO/PRO's full line of automatic gate openers and access controls visit our website at [www.gtopro.com](http://www.gtopro.com)

R3000XL INST  
rev - 9/10/07

The GTO/PRO® 3000XL Gate Operator is intended for use with vehicular swing gates. The operator can be used in Class I, Class II, Class III and Class IV applications.

**VEHICULAR GATE OPERATOR CLASS CATEGORIES**

**Residential Vehicular Gate Operator-Class I:** A vehicular gate operator (or system) intended for use in a home of one-to-four single family dwelling, or a garage or parking area associated therewith.

**Commercial/General Access Vehicular Gate Operator-Class II:** A vehicular gate operator (or system) intended for use in a commercial location or building such as a multifamily housing unit (five or more single family units), hotel, garages, retail store, or other building servicing the general public.

**Industrial/Limited Access Vehicular Gate Operator-Class III:** A vehicular gate operator (or system) intended for use in an industrial location or building such as a factory or loading dock area or other locations not intended to service the general public.

**Restricted Access Vehicular Gate Operator-Class IV:** A vehicular gate operator (or system) intended for use in a guarded industrial location or building such as an airport security area or other restricted access locations not servicing the general public, in which unauthorized access is prevented via supervision by security personnel.

**Conversion Chart**

<i>Converting Metric Units to English Equivalents</i>			
<b>When You Know</b>	<b>Multiply By</b>	<b>To Find</b>	<b>Symbol</b>
centimeters	0.3937	inches	in. (or ")
meters	3.2808	feet	ft. (or')
kilograms	2.2046	pounds	lb. (or #)
<i>Converting English Units to Metric Equivalents</i>			
<b>When You Know</b>	<b>Multiply By</b>	<b>To Find</b>	<b>Symbol</b>
inches	2.5400	centimeters	cm
feet	0.3048	meters	m
pounds	0.4535	kilograms	kg
<i>Converting Temperature</i>			
deg. Celsius	$(^{\circ}\text{C} \times 1.8) + 32$	deg. Fahrenheit	$^{\circ}\text{F}$
deg. Fahrenheit	$(^{\circ}\text{F} - 32) \div 1.8$	deg. Celsius	$^{\circ}\text{C}$

**FOR YOUR RECORDS**

Please record the product serial number (located on the right side of the control box), and the date and place of purchase in the spaces provided below. Refer to this information when calling GTO for service or assistance with your automatic gate operator.

**Serial Number** \_\_\_\_\_ **Date of Purchase** \_\_\_\_\_

**Place of Purchase** \_\_\_\_\_

*Remember to keep all receipts for proof of purchase.*

# Table of Contents

Gate Operator Class Categories-----	inside cover
Units and Standards Conversion Chart -----	inside cover
<b>PLEASE READ THIS FIRST! -----</b>	<b>page iii</b>
<b>Important Safety Instructions -----</b>	<b>page 1</b>
Disconnecting the Operator -----	page 1
Important Safety Instructions for the Consumer-----	page 2
Secondary Means of Protection Against Entrapment -----	page 5
Required Safety Precautions for Gates-----	page 6
Warning Signs and Labels -----	page 7
<b>Installation -----</b>	<b>page 8</b>
Parts List -----	page 8
Technical Specifications -----	page 10
Installation Overview -----	page 11
Installation of the Mounting Hardware -----	page 12
Mounting the Operator -----	page 16
Installation of the Closed Position Stop -----	page 16
Mounting the Control Box-----	page 17
Connecting the Power Cable -----	page 18
<b>Powering the System -----</b>	<b>page 19</b>
Solar Chart-----	page 19
Connecting the Transformer-----	page 19
<b>Control Board Settings -----</b>	<b>page 22</b>
DIP Switches -----	page 22
Setting the Closed Position -----	page 23
Obstruction Sensitivity -----	page 24
<b>Setting Your Personal Transmitter Code -----</b>	<b>page 25</b>
<b>Installing the Receiver -----</b>	<b>page 26</b>
<b>Connecting Accessories -----</b>	<b>page 27</b>
Input Connections-----	page 27
Wiring Accessories -----	page 28
<b>Push to Open Installation -----</b>	<b>page 29</b>
Setting Open Position Limits-----	page 30
<b>Troubleshooting Guide -----</b>	<b>page 32</b>
<b>Repair Service -----</b>	<b>page 34</b>
<b>Column Installation Information -----</b>	<b>page 36</b>
<b>Accessory Catalog -----</b>	<b>page 37</b>

**KEEP THESE INSTRUCTIONS FOR FUTURE REFERENCE**



## PLEASE READ THIS FIRST!

Thank you for purchasing a **GTO/PRO® 3000XL**. When correctly installed and properly used, your **GTO/PRO® 3000XL Operator** will give you many years of reliable service. Please read the following information to ensure you have the correct system for your particular needs. This manual will enable you to properly install your **GTO/PRO® 3000XL Automatic Gate Operator**.

The **GTO/PRO® 3000XL Operator** is designed for installation on a **pull-to-open single leaf gate** (gates that open *into* the property). By purchasing an *accessory bracket*, the **GTO/PRO® 3000XL Operator** can accommodate a **push-to-open single leaf gate** (gates that open *out* from the property). The gate must not exceed 16 feet in length (per leaf) nor weigh more than 650 pounds (per leaf) (please see *Technical Specifications* on page 10). The **GTO/PRO® 3000XL Operator** can be used on vinyl, aluminum, chain link, farm tube, and wrought iron gates. Use on solid (wood) gates is not recommended. Solid surface gates have a high resistance to the wind. If the wind is strong enough, the operator will obstruct and stop.

The **GTO/PRO® 3000XL Operator** accommodates extra transmitters, digital keypads, solar panels, push buttons, automatic gate locks, and other access control products. These optional accessories (see the enclosed *GTO/PRO® Accessory Catalog*) are available.

The **GTO/PRO® 3000XL Operator** features **adjustable obstruction sensing**. This safety feature makes the gate stop and reverse direction within 2 seconds when it comes in contact with an obstruction. **MIN** is the factory setting; meaning the gate will exert the minimum force on an obstruction before it stops and reverses direction.

The **GTO/PRO® 3000XL Operator** also has an **adjustable auto-close feature**. After the gate reaches the fully open position, it can be set to remain open up to 120 seconds before automatically closing. Pressing the transmitter button at any time after the gate opens fully will cause it to close immediately. **OFF** is the factory setting; meaning the gate will stay open until you press the transmitter (or keypad, etc.) again.

Please call GTO at **(800) 543-GATE [4283]** or **(850) 575-0176** for more information about our **GTO/PRO®** professional line of gate operators and accessories. Our Sales Department will be glad to give you the name and phone number of a **GTO/PRO®** dealer near you.

**BEFORE YOU BEGIN TO INSTALL YOUR AUTOMATIC GATE OPERATOR:**  
Read these instructions *carefully and completely* to become familiar with all parts and installation steps.  
You must read the installation manual for detailed instructions on gate operator safety and proper use of the gate operator.

# ⚠ IMPORTANT SAFETY INSTRUCTIONS ⚠

Because automatic gate operators produce high levels of force, consumers need to know the potential hazards associated with improperly designed, installed, and maintained automated gate operator systems. **Keep in mind that the gate operator is just one component of the total gate operating system.** Each component must work in unison to provide the consumer with convenience, security, and safety.

This manual contains various safety precautions and warnings for the consumer. Because there are many possible applications of the gate operator, the safety precautions and warnings contained in this manual cannot be completely exhaustive in nature. They do, however, provide an overview of the safe design, installation, and use of this product. **CAREFULLY READ AND FOLLOW ALL SAFETY PRECAUTIONS, WARNINGS, AND INSTALLATION INSTRUCTIONS TO ENSURE THE SAFE SYSTEM DESIGN, INSTALLATION, AND USE OF THIS PRODUCT.**

Precautions and warnings in this manual are identified with this  warning symbol. The symbol identifies conditions that can result in damage to the operator or its components, serious injury, or death.

Because GTO automatic gate operators are *only part* of the total gate operating system, it is the responsibility of the consumer to ensure that the total system is safe for its intended use.

## To Manually Open and Close the Gate, Follow the Procedure Below:

 **CAUTION:** The gate will move freely and uncontrolled when the gate operator is removed from the gate. **ONLY** disconnect the operator when the control box power switch is **OFF** and the gate is **NOT** moving.

### Disconnecting the Operator

1. Turn control box power switch **OFF**.
2. Remove hairpin clip, clevis pin, and bushing from either the front or rear mounting point.
3. Remove the opener from the mount.

*The gate can be opened and closed manually when the operator is disconnected.*

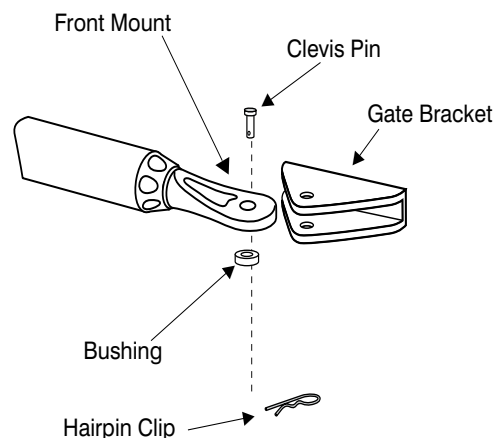

**NOTE:** Substitute a **Pin Lock** for the clevis pin on the front mount of the gate operator to prevent unauthorized removal of the operator from the gate (see *Accessory Catalog*).

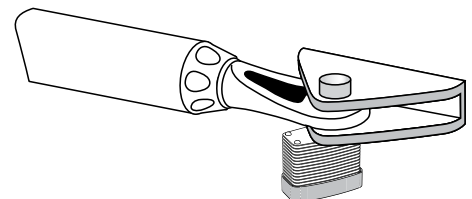

# ⚠️ IMPORTANT SAFETY INSTRUCTIONS ⚠️

## For The Consumer

### WARNING: To reduce the risk of injury or death:

1. **READ AND FOLLOW ALL INSTRUCTIONS.** Failure to meet the requirements set forth in the instruction manual could cause severe injury and/or death, for which the manufacturer cannot be held responsible.
2. When designing a system that will be entered from a highway or main thoroughfare, make sure the system is placed far enough from the road to prevent traffic congestion.
3. The gate must be installed in a location that provides adequate clearance between it and adjacent structures when opening and closing to reduce the risk of entrapment. Swinging gates **must not** open into public access areas.
4. The gate and gate operator installation **must comply with any applicable local codes.**

#### I. Before Installation

1. Verify this operator is proper for the type and size of gate, its frequency of use and the proper class rating.
2. Make sure the gate has been properly installed and swings freely in both directions. Repair or replace all worn or damaged gate hardware prior to installation. A freely moving gate will require less force to operate and will enhance the performance of the operator and safety devices used with the system.
3. Review the operation of the system to become familiar with its safety features. Understand how to disconnect the operator for manual gate operation (*see page 1*).
4. This gate operator is intended for **vehicular gates ONLY**. A separate entrance or gate must be installed for pedestrian use (*see page 6*).
5. Always keep people and objects away from the gate and its area of travel. **NO ONE SHOULD CROSS THE PATH OF A MOVING GATE.**
6. Pay close attention to the diagram below and be aware of these areas at all times.

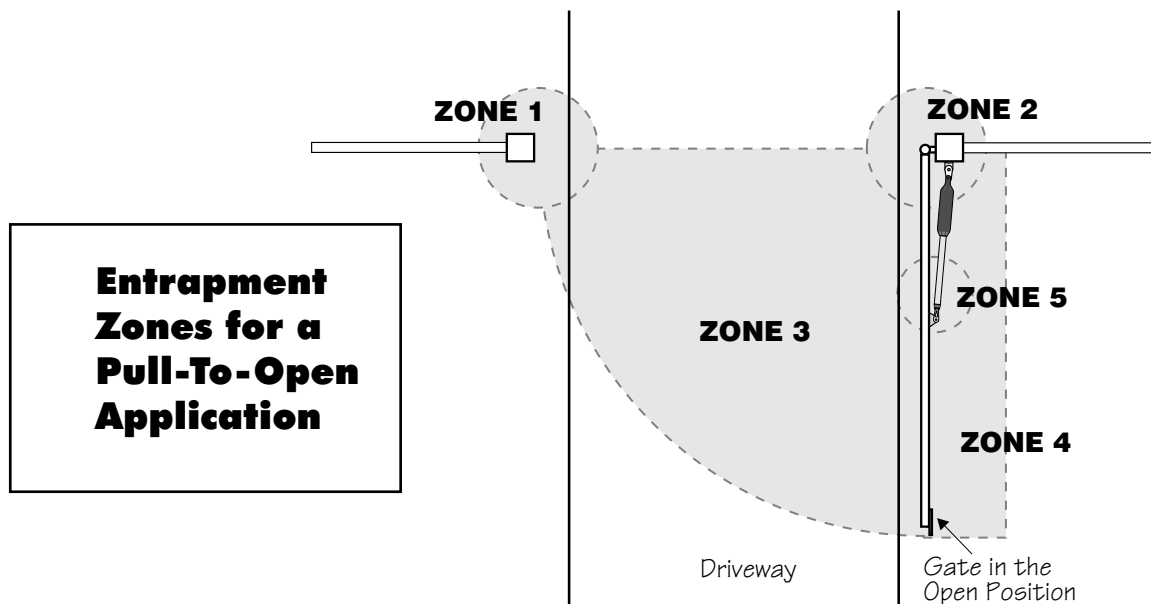

# ! IMPORTANT SAFETY INSTRUCTIONS !

Entrapment Zones for a proper Pull-To-Open installation:

Zone 1 – leading edge of the gate and the fence post.

Zone 2 – between the gate and the gate post.

Zone 3 – the path of the gate.

Zone 4 – the space between the gate in the open position and any object such as a wall, fence, tree, etc.

Zone 5 – pinch points between the opener and gate.

## II. During Installation

1. Install the gate opener on the inside of the property and fence line. **DO NOT** install an opener on the outside of the gate where the public has access to it.
2. Be careful with moving parts and avoid close proximity to areas where fingers or hands could be pinched.
3. Devices such as contact sensors (safety edges) and non contact sensors (photo beams) provide additional protection against entrapment.
4. If push buttons or key switches are installed, they should be within sight of the gate, yet located at least 10 feet from any moving part of the gate (see diagram below). *Never install any control device where a user will be tempted to reach through the gate to activate the gate opener.*
5. Do not activate your gate opener unless you can see it and can determine that its area of travel is clear of people, pets, or other obstructions. Watch the gate through its entire movement.
6. Secure outdoor or easily accessed gate opener controls in order to prohibit unauthorized use of the gate.

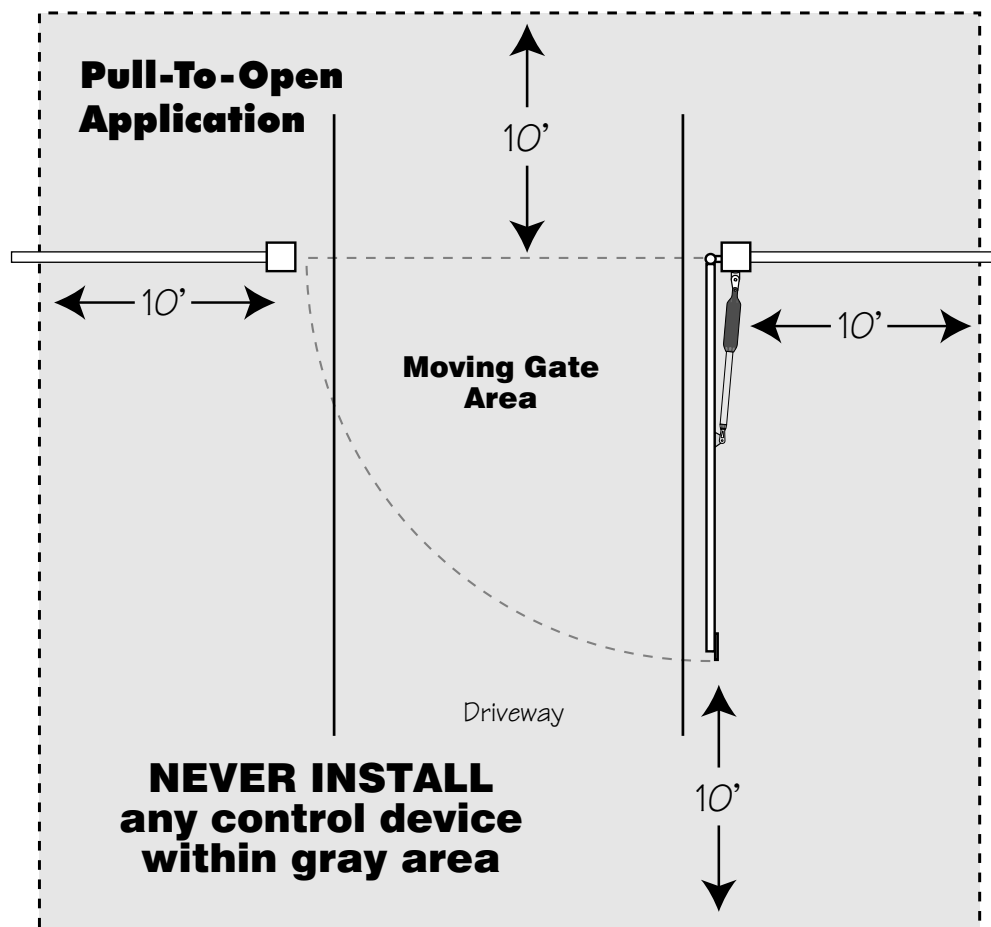

# **IMPORTANT SAFETY INSTRUCTIONS**

## III. After Installation

1. Attach the **warning signs** (*included*) to each side of the gate to alert the public of automatic gate operation. It is *your responsibility* to post warning signs on both sides of your gate. If any of these signs or warning decals become damaged, illegible or missing, replace them immediately. Contact GTO for free replacements.
2. The gate is automatic and could move at any time, posing a serious risk of entrapment. No one should be in contact with the gate when it is moving or stationary.
3. Do not attempt to drive into the gate area while the gate is moving; wait until the gate comes to a complete stop.
4. Do not attempt to "beat the gate" while the gate is closing. This is extremely dangerous.
5. Do not allow children or pets near your gate. **Never let children operate or play with gate controls.** Keep the remote controls away from children and unauthorized users; store controls where children and unauthorized users do not have access to them.
6. **KEEP GATES PROPERLY MAINTAINED.** Always turn power to operator OFF before performing any maintenance. Clean the push-pull tube with a soft, dry cloth and apply silicone spray to it at least once per month.
7. Service the gate and gate operator regularly. Grease hinges, spray push pull tube with high quality silicone spray and replace the battery every 3-5 years.
8. To operate this equipment safely, YOU must know how to disconnect the operator for manual gate operation (*see page 1*). If you have read the instructions and still do not understand how to disconnect the operator, contact the GTO Service Department.
9. Disconnect the operator **ONLY** when the power is **TURNED OFF** and the gate is **NOT** moving.
10. Make arrangements with local fire and law enforcement for emergency access.
11. Distribute and discuss copies of the **IMPORTANT SAFETY INSTRUCTIONS** section of this manual with all persons authorized to use your gate.
12. **IMPORTANT: Save these safety instructions. Make sure everyone who is using or will be around the gate and gate operator are aware of the dangers associated with automated gates. In the event you sell the property with the gate operator or sell the gate operator, provide a copy of these safety instructions to the new owner.**

**Should you lose or misplace this manual, a copy can be obtained by downloading one from the GTO/PRO® web site ([www.gtopro.com](http://www.gtopro.com)), by contacting GTO, Inc., at 3121 Hartsfield Road, Tallahassee, Florida 32303 or by calling 1-800-543-4283 and requesting a duplicate copy. One will be provided to you free of charge.**



# ⚠ IMPORTANT SAFETY INSTRUCTIONS ⚠

## Secondary Means of Protection Against Entrapment

As specified by Gate Operator Safety Standard, UL 325 (30A.1.1), automatic gate operators shall have an inherent entrapment sensing system, and shall have *provisions for, or be supplied with*, at least one independent secondary means to protect against entrapment. The GTO/PRO® 3000XL utilizes **Type A**, an inherent (i.e., built-in) entrapment sensing system as the *primary* type of entrapment protection. Also, the GTO/PRO® 3000XL has *provisions for* the connection of **Type B2** protection to be used as the *secondary* type of entrapment protection, if desired.

1. For gate operators utilizing a contact sensor (e.g., safety edge sensor– Type B2) in accordance with UL 325 (51.8.4 [i]):
  - A. One or more contact sensors shall be located at the leading edge, bottom edge, and post edge, both inside and outside of a vehicular swing gate system.
  - B. A hard wired contact sensor shall be located and its wiring arranged so that the communication between the sensor and the gate operator is not subjected to mechanical damage.
  - C. A wireless contact sensor such as one that transmits radio frequency (RF) signals to the gate operator for entrapment protection functions shall be located where the transmission of the signals are not obstructed or impeded by building structures, natural landscaping or similar obstruction. A wireless contact sensor shall function under the intended end-use conditions.

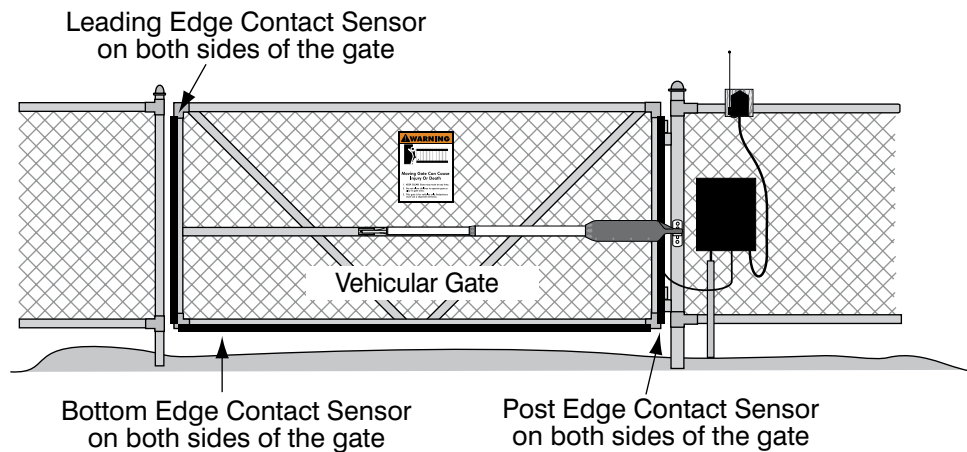

### **ENTRAPMENT ALARM (UL 325; 30A.1.1A)**

The GTO/PRO® 3000XL Automatic Gate Operator is designed to stop and reverse within 2 seconds when the gate comes in contact with an obstruction. Additionally, these operators are equipped with an **audio entrapment alarm** which will activate if the unit obstructs *twice* while opening or closing. This alarm will sound for a period of 5 minutes, or until the operator receives an intended signal from a hardwired entry/exit source (e.g. push button control or keypad) and the gate returns to a fully open or fully closed position. Turning the power switch on the control box OFF and back ON will also deactivate the alarm. Wireless controls such as transmitters and wireless keypads will not deactivate the alarm.

# ⚠️ IMPORTANT SAFETY INSTRUCTIONS ⚠️

## Required Safety Precautions for Gates Install Warning Signs

**Warning signs** alert people of automatic gate operation and are **required** when installing the GTO/PRO® 3000XL Automatic Gate Operator. Furthermore, a walk-through gate must be installed if pedestrian traffic is expected near the vehicular gate. We recommend using the **GTO Bulldog Pedestrian Gate Lock** (Call the GTO Sales Department) for controlled access.

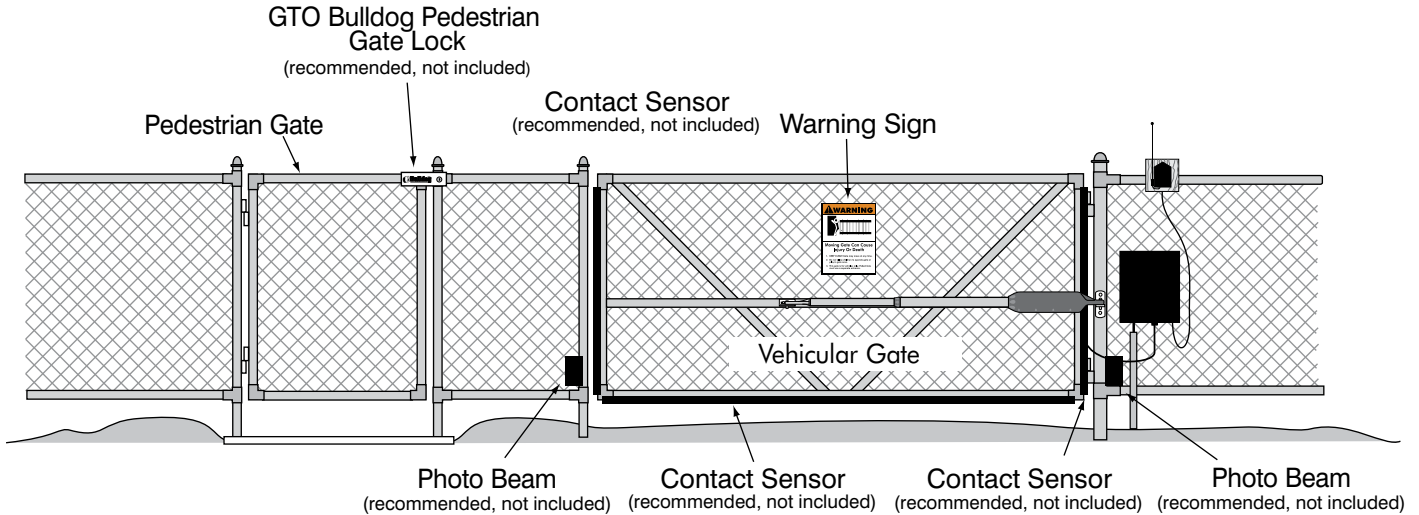

## Entrapment Protection

GTO's inherent obstruction settings, even when properly adjusted, *may not be sensitive enough to prevent bodily injury in some circumstances*. For this reason, safety devices such as safety edge sensors (or photoelectric sensors), which stop and reverse gate direction upon sensing an obstruction, are suggested for enhanced protection against entrapment.

## Warning Signs

The warning signs (*at right*) must be installed on both sides of the gate (*see page 7 for details*).



# ⚠ IMPORTANT SAFETY INSTRUCTIONS ⚠

## WARNING

### Moving Gate Can Cause Injury Or Death

1. **KEEP CLEAR!** Gate may move at any time.
2. **Do not allow children to operate gate or play in gate area.**
3. **This gate is for vehicles only. Pedestrians must use a separate entrance.**

Warning signs (2 enclosed) to be installed on each side of the gate (3–5 feet above the bottom of the gate)

These warning labels should be found at the locations specified below. If any of them are missing, immediately contact GTO for replacements.

c LISTED us  
#XXXXXXXX

**GTO DC SW-3000XL SERIES**  
**Conforms to UL 325 STANDARDS**  
 Maximum Gate: 650 lb. (294.8 kg); 16 ft. (4.8 m)  
 Voltage: 12 Vdc; Frequency: 0 Hz; Power: 40 W  
 Class I, II, III and IV Vehicular Swing Gate Operator.  
 Serial Number: XXXXXXXXX

**TO MANUALLY OPEN AND CLOSE THE GATE:**

1. Turn control box power switch OFF.
2. Disconnect front or rear mount from gate bracket.
3. Pull operator away from front or rear mounts.

**Disconnect operator ONLY when the control box power switch is OFF and the gate is NOT moving.**

GTO, Inc. Tallahassee, Florida USA

Product identification and manual operation instruction label (1) installed on right side of control box.

1-800-543-GATE (4283) • www.gtopro.com

## WARNING

### Moving Gate Can Cause Injury or Death

1. **KEEP CLEAR!** Gate may move at any time.
2. **Do not allow children to operate gate or play in gate area.**
3. **This gate is for vehicles only. Pedestrians must use separate entrance.**

Logo and warning labels (2) installed on each side of operator housing.

# Single Gate Operator Parts List

## Operator and Mounting Hardware

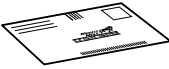

Customer Support Card (1)

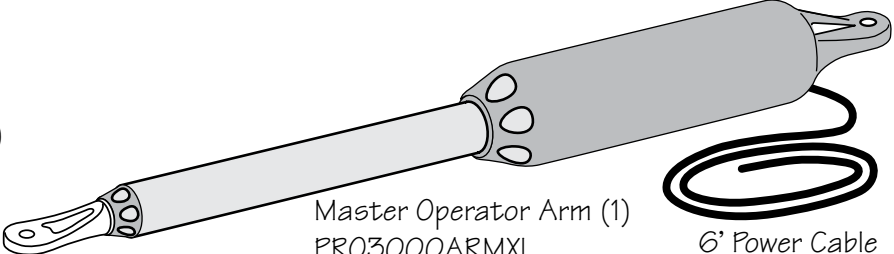

Master Operator Arm (1)  
PR03000ARML

6' Power Cable

### BRACKET BOX - HB3000

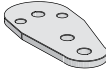

Post Pivot Bracket (1)

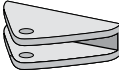

Gate Bracket (1)

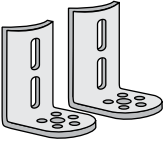

Post Bracket (2)

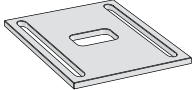

Closed Position Stop Plate (1)

### HARDWARE BAG - H101P

8" Nylon Cable Tie (14)

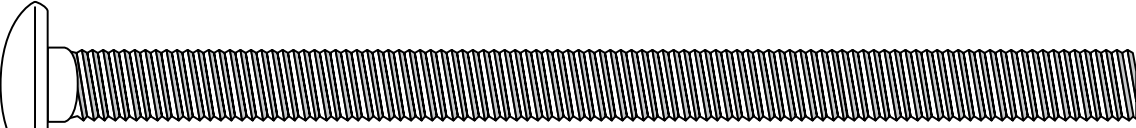

3/8" x 8" Bolt (4)

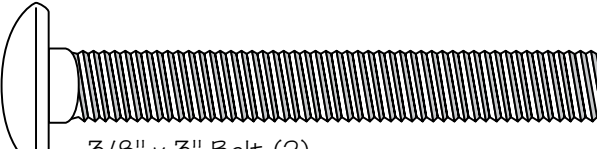

3/8" x 3" Bolt (2)

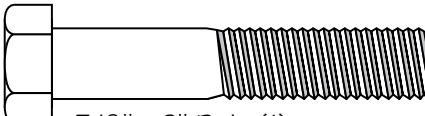

3/8" x 2" Bolt (1)

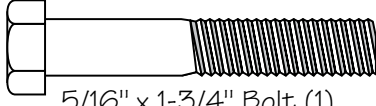

5/16" x 1-3/4" Bolt (1)

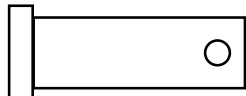

3/8" x 1-1/4" Clevis Pin (2)

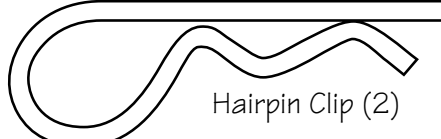

Hairpin Clip (2)



2" Receiver Mounting Screw (5)

3/8" Washer (9)

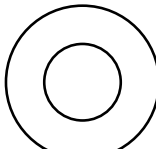

3/8" Lock Washer (7)



5/16" Washer (1)



3/8" Nut (7)



5/16" Nut (1)



3/8" Bushings (2)



# Single Gate Operator Parts List (continued)

## Control Box and Electrical Components

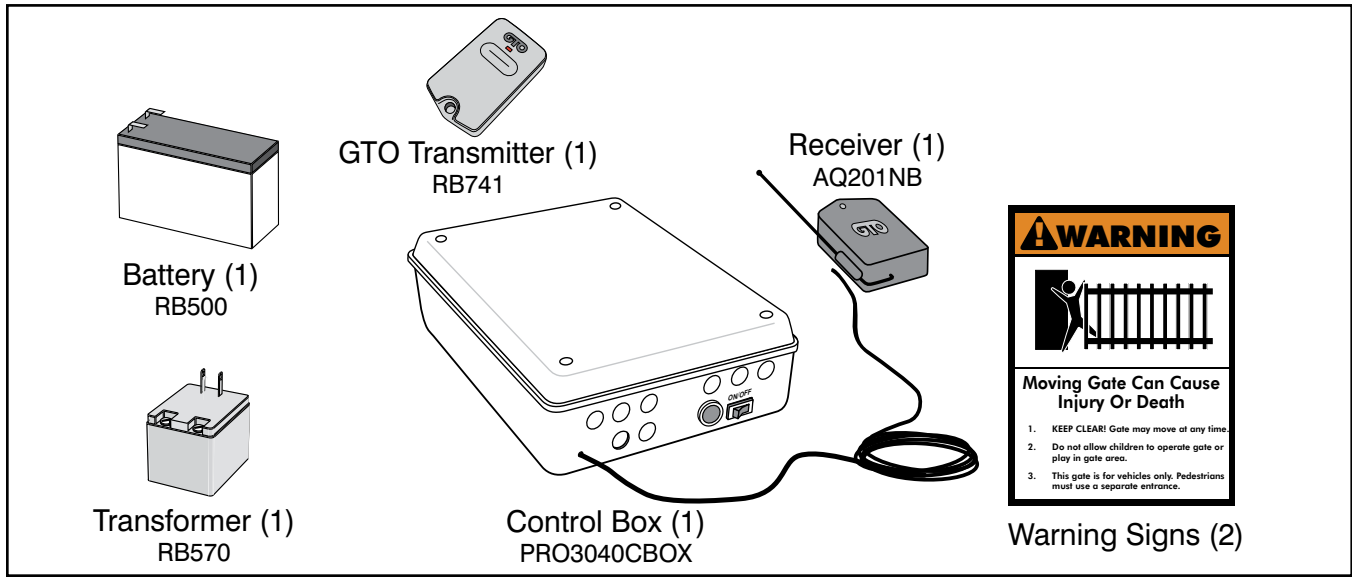

### Tools Needed

- Power Drill
- Open End Wrenches — 3/8", 7/16", 1/2", 9/16"
- 3/8" Drill Bit
- Pliers
- Hacksaw or Heavy Duty Bolt Cutters
- Small (Flat Head) Screwdriver
- Phillips Head Screwdriver
- Tape Measure
- Level
- Wire Strippers
- C-Clamps — small, medium, and large
- Center Punch
- Adjustable Wrench
- Extra person will be helpful

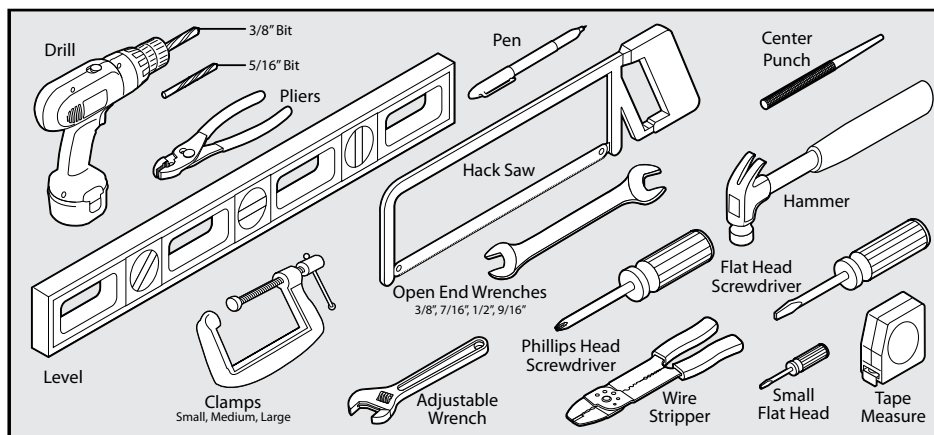

### YOU MAY ALSO NEED THESE ITEMS BEFORE YOU BEGIN THE INSTALLATION (Some of these items can be found in the *Accessory Catalog* page 37):

- **Low voltage wire** will be needed to run from the transformer to the control box; length depends upon the distance between the transformer power supply and the control box. See **Powering the System** on page 19, and the *Accessory Catalog*.
- If your gate is more than 1000' away from an ac power source you will need to use at least 5 watts of solar charging power to trickle charge the battery. See the *Accessory Catalog*.
- If your fence post is made of wood and is less than 6" in diameter or 6" square, see page 12.
- If your fence post is larger than 6" in diameter you will need **threaded rods or carriage bolts longer than 8"**. See pg 15.
- PVC conduit.
- If you have thin walled tube or panel gates, see **Recommended Reinforcement Examples** on page 12.
- Depending on the type of gate, a **horizontal cross member or mounting plate may be needed** to mount the front of the opener and gate bracket to the gate. See page 11, step 2; page 15, step 10.
- Surge protection for transformer.
- Some types of installations require U-Bolts.
- Weatherproof cover for transformer if installed outside.
- For push-to-open applications you must have PTO Bracket 347IH.

# Technical Specifications

## GTO/PRO® 3000XL AUTOMATIC GATE OPERATOR

### DRIVE

- Low friction screw drive (linear actuator) rated for -5 °F to +160 °F (-21 °C to +71 °C). Use of heater bands on arm and control box will enhance performance in extreme cold temperatures.
- Powered by a 12 V motor with integral case hardened steel gear reducer. Motor speed reduced to 300 rpm.
- Maximum opening arc of 110°. Approximate opening time (90°): 15-18 seconds, depending on weight of gate.

### POWER

- The system is powered by a 12 Vdc, 7.0 Ah, sealed, rechargeable acid battery.
- Battery charge is maintained by a 120 Vac, 18 Vac output transformer rectified to 14.5 Vdc (40 VA) through the GTO control board. Blade-style control board fuse is rated for 25 A.

**NOTE: The transformer should not be directly connected to any battery. Do not replace fuses with higher ampere rated fuses; doing so will void your warranty and may damage your control board.**

- For optional solar charging see page 19.

### CONTROL

- GTO microprocessor-based control board is set for single leaf, pull-to-open gate installations. DIP switches can be adjusted to accommodate an optional kit for push-to-open gates (*see Accessory Catalog*).
- Control board has temperature compensated circuits.
- A circuit on the control board regulates charging. "Sleep draw" is 40 mA; "active draw" is 3 to 7 A.
- Auto-memorization of digital transmitter code.
- GTO remote-mounted RF receiver tuned to 318 MHz.
- Operator length with push-pull tube fully retracted is 40<sup>1/4</sup>", mounting point to mounting point. (Maximum Stroke 16")
- Adjustable auto-close timer (OFF to 120 s), and obstruction sensitivity.
- Power terminal block accommodates a transformer or solar panels (not both).
- DIP switches simplify setup of gate operator.
- Accessory terminal block fully compatible with push button controls, digital keypads, safety loops, etc.
- Control board allows connection of safety edge sensors and photoelectric sensors.
- Audio entrapment alarm sounds if unit encounters an obstruction twice while opening or closing.

### OPERATIONAL CAPACITY

- The Gate Capacity Chart shows approximate cycles, per day, you can expect from the GTO/PRO® 3000XL Automatic Gate Operator when powered with a transformer. Actual cycles may vary slightly depending upon the type and condition of gate and installation.

<b>GTO/PRO® 3000XL Gate Capacity Chart</b>									
<i>Estimated number of daily cycles, based on use with a transformer and one(1) 12 Volt battery</i>									
Gate Length	16 ft.	160	150	140	130	120	110	100	90
	14 ft.	170	160	150	140	130	120	110	100
	12 ft.	180	170	160	150	140	130	120	110
	5 - 10 ft.	190	180	170	160	150	140	130	120
	50 lb.	100 lb.	150 lb.	200 lb.	300 lb.	400 lb.	500 lb.	650 lb.	
<b>Gate Weight</b>									

**NOTE: BALL BEARING HINGES SHOULD BE USED ON ALL GATES WEIGHING OVER 250 LB.**

To determine the number of cycles the gate operator will perform using solar panels, please see the specifications listed on page 20 or call (800) 543-1236 or (850) 575-4144 for more information.

\* An operation cycle is one full opening and closing of the gate.

These specifications are subject to change without notice.

# Installation Overview

## Pull-to-Open Gates (Gate Opens into the Property)

The diagram shown below is an example of a pull-to-open installation on a chain link fence and single gate. Mounting the operator on a masonry column requires special procedures; see **Column Installation Information** on page 36 if you intend to mount the operator on a column. Furthermore, if you have a push-to-open gate, you will need to purchase a **push-to-open bracket** (see *Accessory Catalog*) to properly configure your system. See **Push to Open Installation** on page 30 before proceeding.

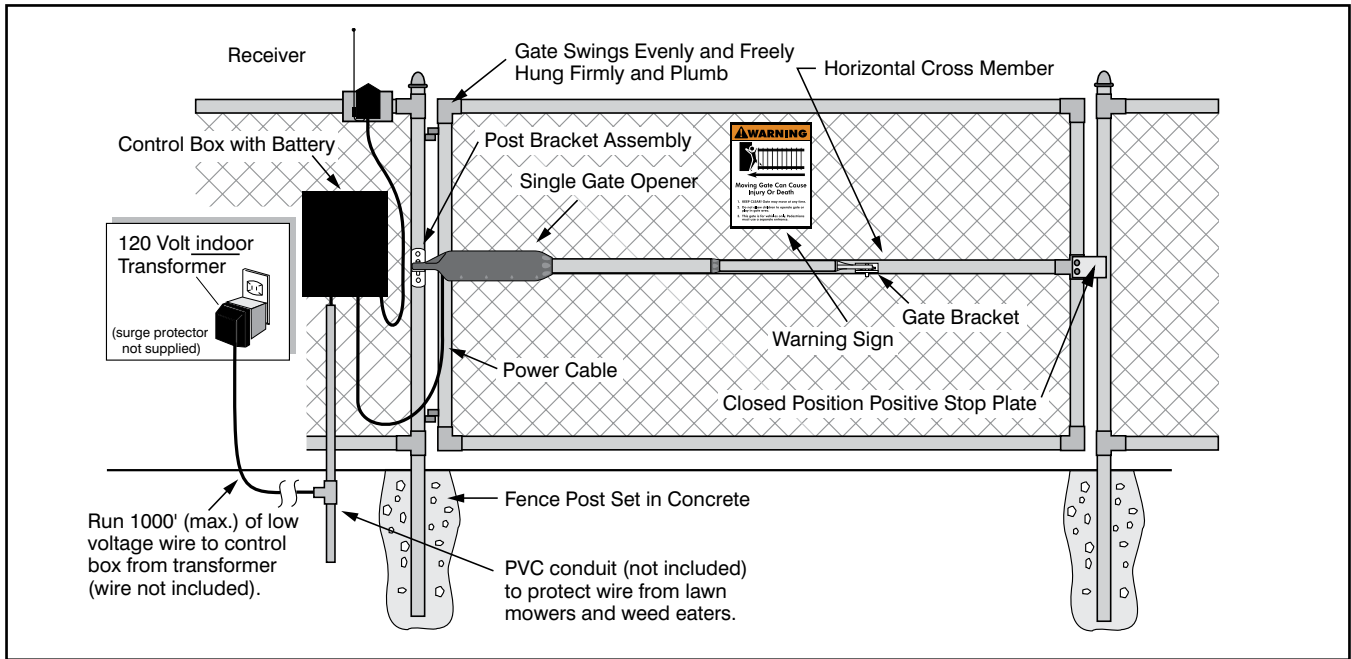

## Preparation of the Gate

### Step 1

The gate **must** be plumb, level, and swing freely on its hinges. Wheels must not be attached to the gate. The gate must move throughout its arc **without binding or dragging on the ground**. Note that gates over 250 lb. should have ball bearing hinges with grease fittings.

### Step 2

The fence post must be secured in the ground with concrete so it will minimize twist or flex when the operator is activated. We recommend you position the operator near the **centerline** of the gate to keep the gate from twisting and flexing and to avoid backsplash from the ground. The addition of a **horizontal or vertical cross member** (if one is not already in place) to provide a stable area for mounting the gate bracket is also important.

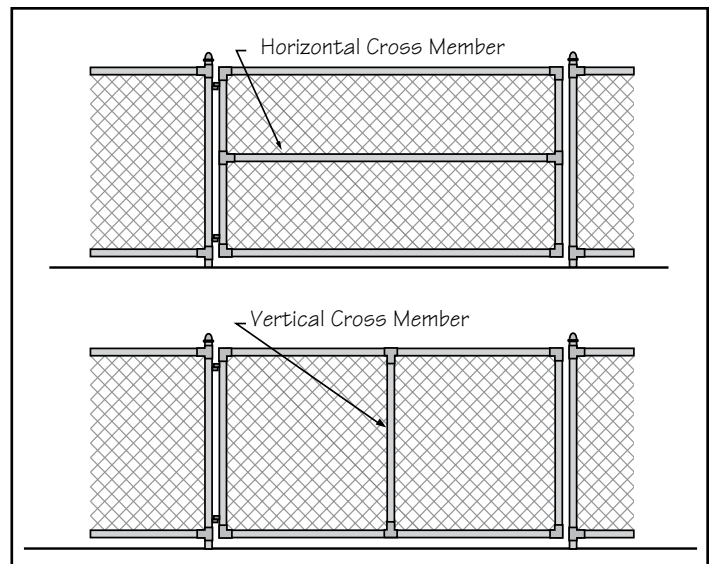

# Installation of Mounting Hardware

The position of the post bracket determines the leverage and efficiency of the operator. The post bracket position also sets the clearance between the operator and gate in the open and closed positions (minimum 2 inches for safety reasons).

The curved design of the post bracket works well for installations on round and square fence posts. Because the post bracket carries the entire thrust of the active operator, **bolts that completely penetrate the fence post must be used.**

On wooden posts, place a metal plate or washer (*not supplied*) between the nuts and the fence post to prevent the thrust of the operator from pulling the bolts and washers out of the wood.

**NOTE:** A fence post smaller than 6" in diameter or 6" square should be made of metal instead of wood so that it will remain stable while the operator is moving the gate.

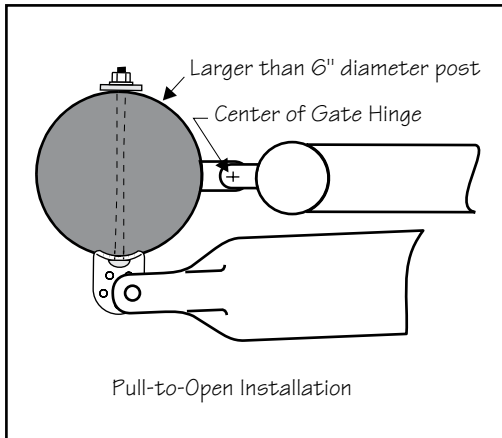
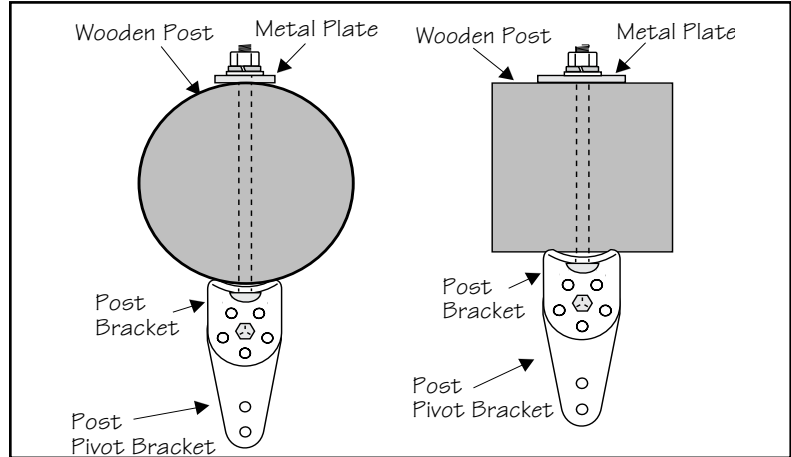

On round posts of 6" diameter or larger, the post pivot bracket may not be necessary for the installation. In this instance, the two post brackets are mounted by themselves.

## IMPORTANT:

We **strongly recommend** using steel pipe, wood or metal to reinforce thin walled tube gates or wood to reinforce panel gates as shown. These reinforcement methods will prevent damage to the operator and gate when the operator is installed.

## Recommended Reinforcement Examples

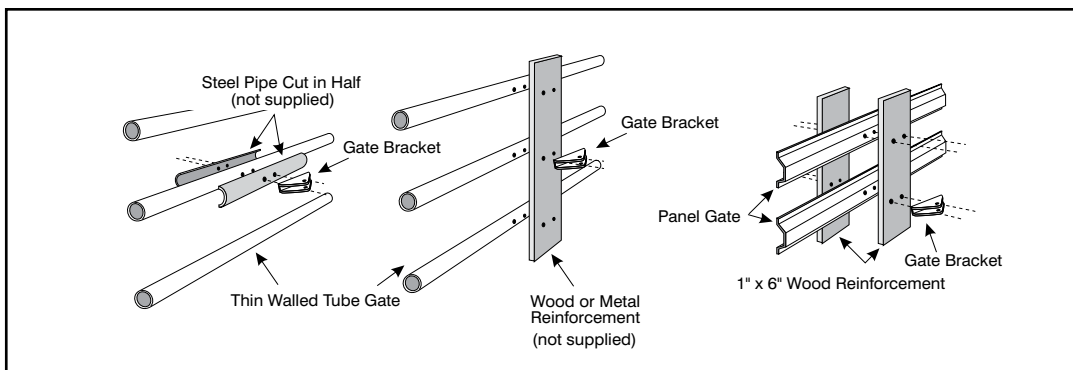



# Determining the Mounting Position of the Post Bracket Assembly and the Gate Bracket

## Step 3

Insert the 3/8" x 2" bolt through the center hole of the post brackets and post pivot bracket as shown. Fasten a 3/8" lock washer, 3/8" washer and 3/8" nut on the end of the bolt. **DO NOT overtighten** the nut because the post pivot bracket will have to be adjusted later.

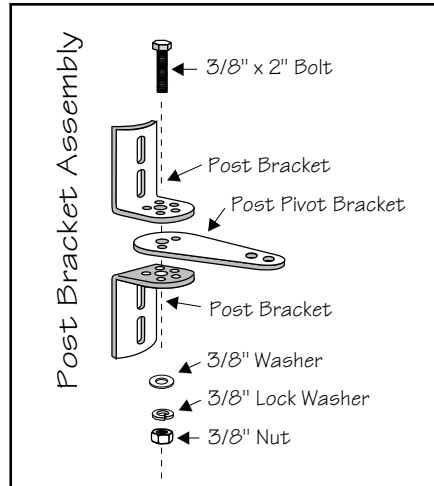

**NOTE:** The following steps are intended for **pull-to-open** gate installations. If you are mounting your operator on a push-to-open gate (e.g., a gate on a sloped driveway) you will need to purchase a **Push To Open** bracket (see *Accessory Catalog*). Also, see **Push-to-Open Installation** beginning on page 30.

## Step 4

Attach post bracket assembly and gate bracket to the operator with the clevis pins and bushings. Secure the clevis pins with hairpin clips.

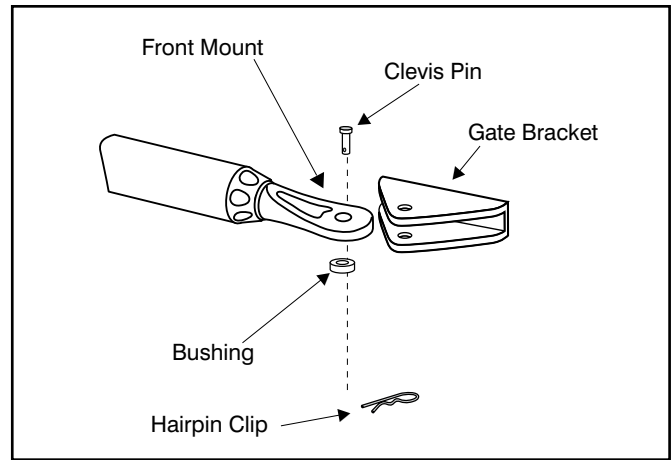
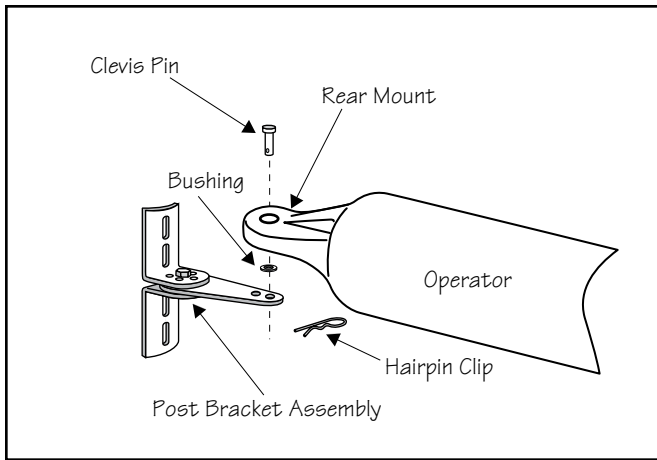

## Step 5

With the gate in the open position (up to 110° from its closed position) and the operator fully retracted, adjust the post bracket assembly and gate bracket until the operator is level. While holding the operator level, use C-clamps to temporarily keep the post bracket assembly and gate bracket in their respective positions on the fence post and gate.

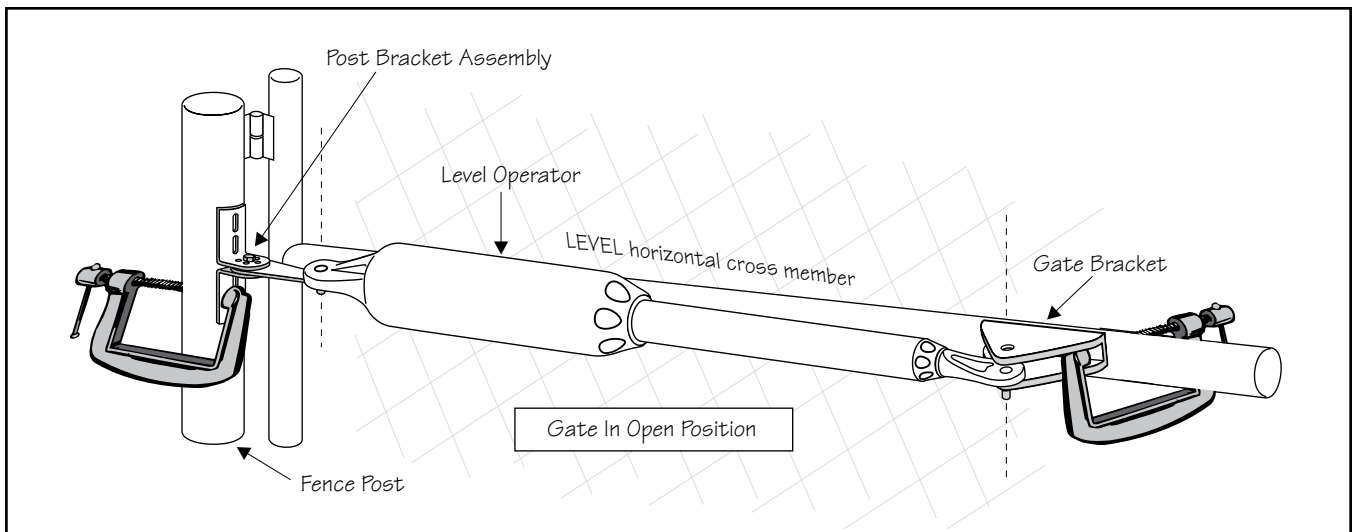

**IMPORTANT:** While determining the mounting point for the post pivot bracket assembly, be sure that the position allows for minimum 2 inches of clearance between the gate and the operator in both the open and closed positions, as shown in the diagrams below. This clearance will give the operator the most efficient leverage point for opening and closing the gate and more importantly provides the least possible pinch area.

## Step 6

When you feel that you have the best position for the post pivot bracket in the open position, insert the 5/16" x 1-3/4" bolt through the aligned holes of the post bracket and post pivot bracket to hold it in place. Remove the clevis pin from the front mount and while supporting the gate operator, swing the gate and gate operator to the closed position. With the gate and gate operator in the closed position check the clearance and be sure that the gate operator is not binding at the post pivot bracket.

If you don't have 2 inches of clearance or the gate operator is binding on the post pivot bracket, remove the 5/16" x 1-3/4" bolt and readjust the pivot bracket until you can achieve these important clearances. Replace the 5/16" x 1-3/4" bolt.

With the post pivot bracket in the optimum position for clearance and freedom of movement, reattach the operator to the gate bracket in the open position and recheck the gate operator level and make sure the brackets are clamped securely.

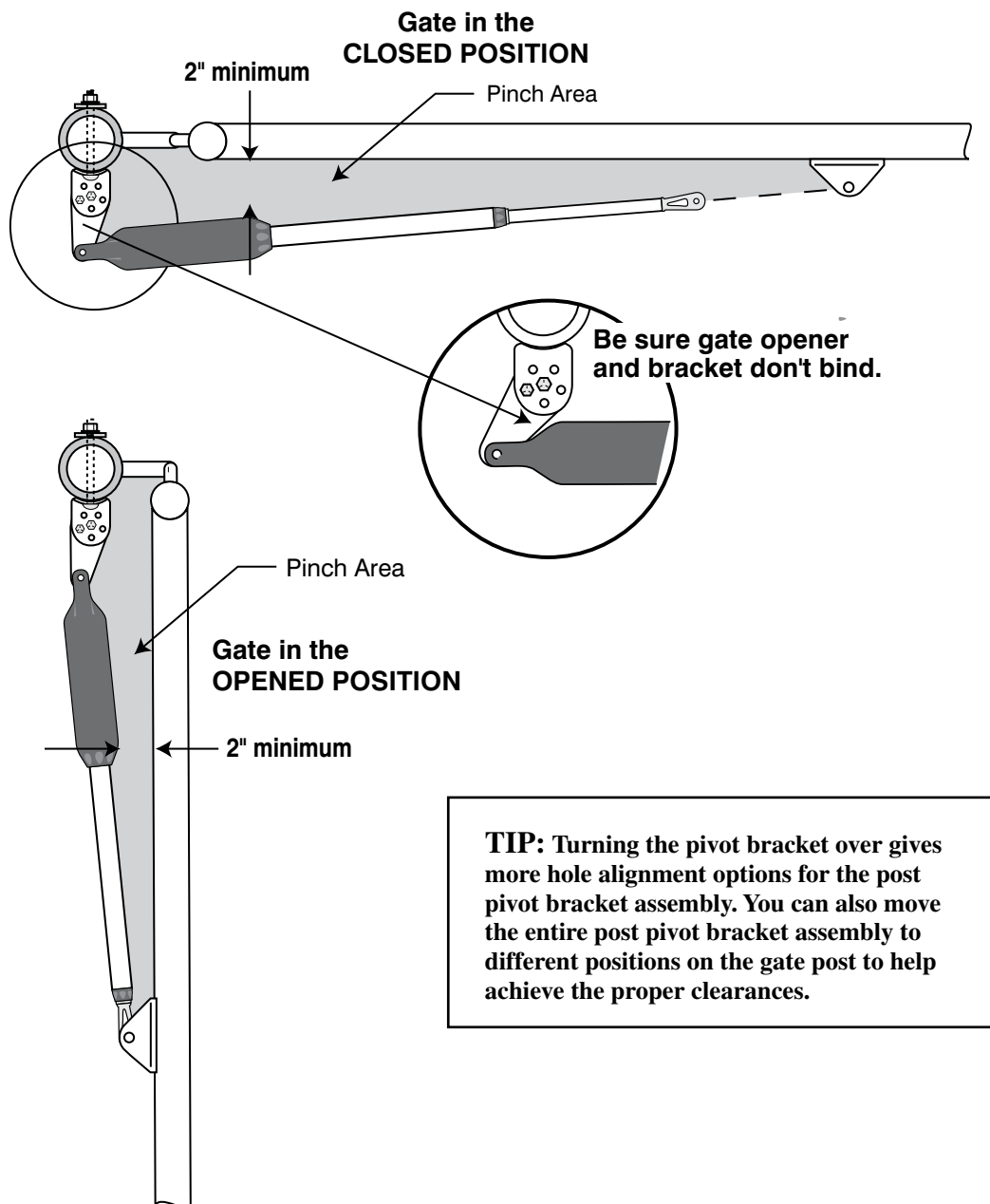

# Installing the Post Bracket Assembly and Gate

## Step 7

Mark reference points for bolt holes on the fence post through middle of bracket slots. Marking reference points in this manner allows room for adjustment when mounting the post bracket assembly and gate bracket. After marking your reference points, remove the operator and brackets from the fence and gate.

## Step 8

Drill  $\frac{3}{8}$ " holes into fence post as marked.

## Step 9

Fasten post bracket assembly to the fence post using (4)  $\frac{3}{8}$ " x 8" bolts, washers, lock washers, and nuts (*provided*). Remove excess bolt length extending beyond the tightened nuts with a hacksaw or bolt cutters.

**NOTE:** In cases where the fence post has a diameter larger than 6", **threaded rods or carriage bolts longer than 8"** (*not supplied*) must be used.

## Step 10

Mark reference points for bolt holes on the gate cross member through middle of gate bracket slots. Drill  $\frac{3}{8}$ " holes into the gate cross member as marked.

Mount gate bracket using (2)  $\frac{3}{8}$ " x 3" bolts, washers, lock washers, and nuts (*provided*). Cut off excess bolt length extending beyond the tightened nuts.

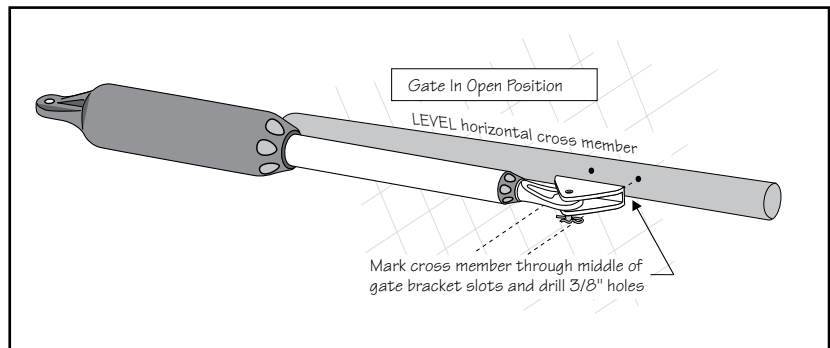
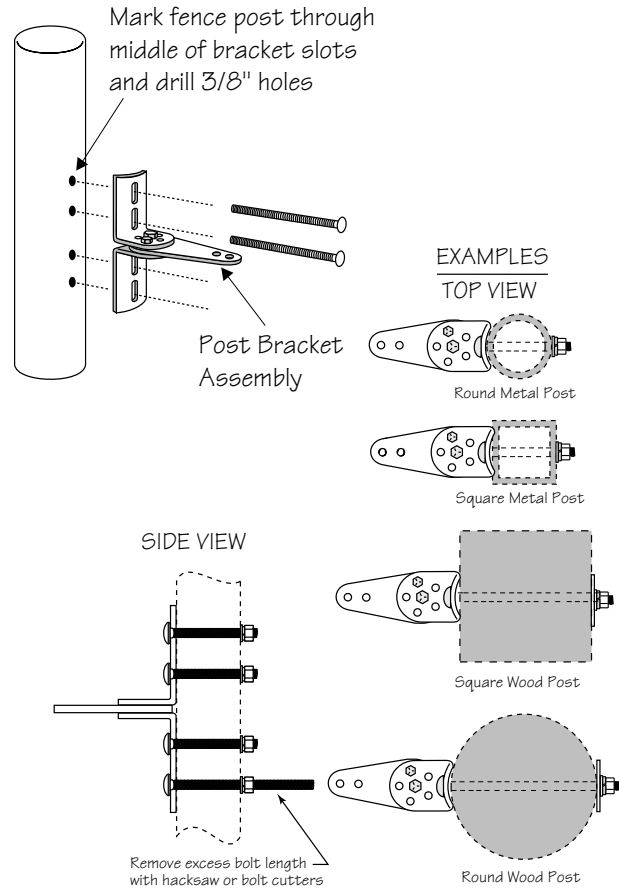

## Gate Bracket Mounting Examples

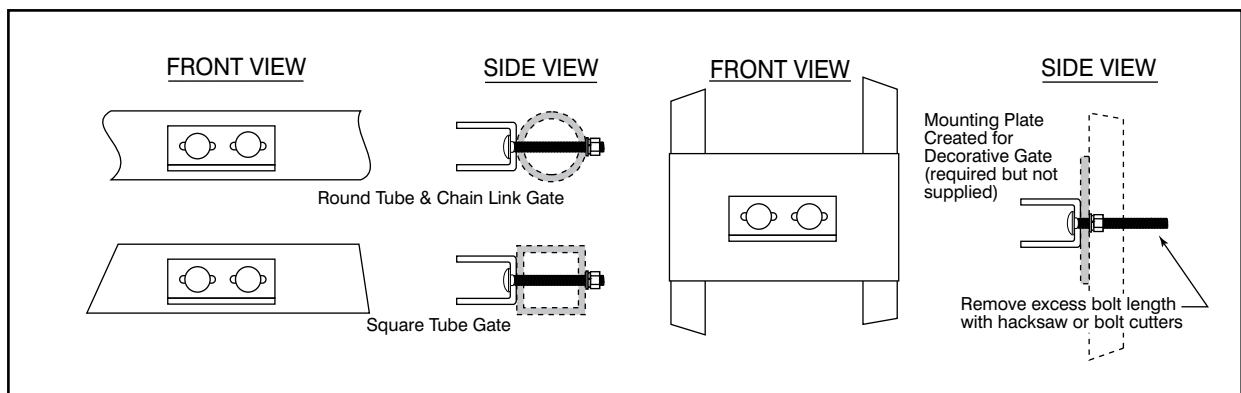

# Mounting the Operator

## Step 11

Attach the operator to the securely bolted post bracket assembly and gate bracket using clevis pins, bushings, and hairpin clips, or optional Pin Locks (see *Accessory Catalog*). Verify that the operator is level and adjust the post bracket assembly if necessary.

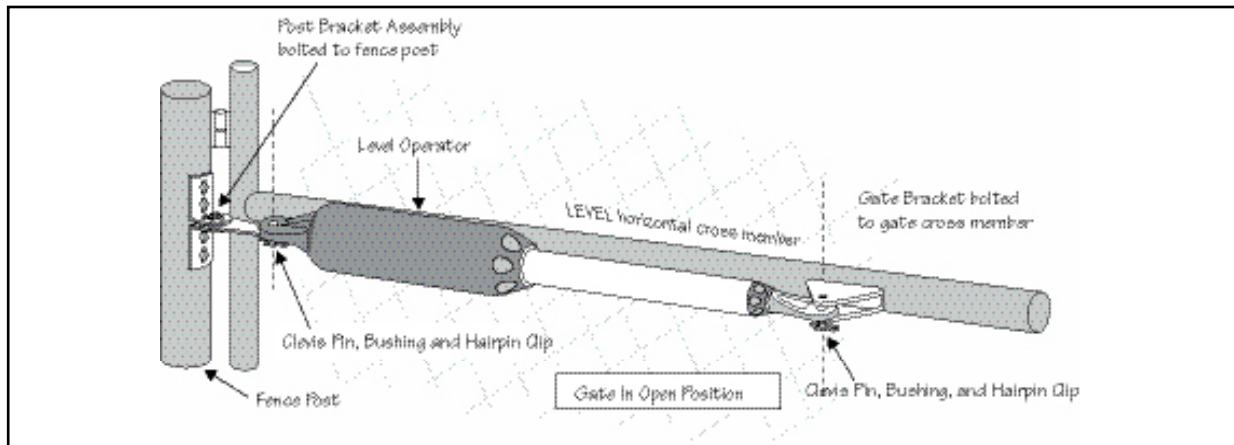

# Installation of the Closed Position Stop

The GTO/PRO® 3000XL Gate Operator firmly holds the gate in the closed position using the positive stop plate. The positive stop helps stabilize the gate leaf in the closed position. To further enhance the stability and security of your gate, install the optional **GTO/PRO® Automatic Gate Lock FM144** (see *Accessory Catalog*).

## Step 12

Remove hairpin, clevis pin, and washer from front mount and close the gate (remember to support operator). Fasten the *closed position stop plate* to the end of the gate frame on the **gate centerline** (in line with the operator arm), but **do not** tighten it completely. Slide the stop plate toward the fence post until they touch (see *illustration*). Once you have moved the stop plate to the correct position, tighten its hardware completely.

Use the appropriate hardware for your type of gate (use U-bolts if you have a tube or chain link gate; wood or lag screws for wood gates; etc.). This hardware is not provided.

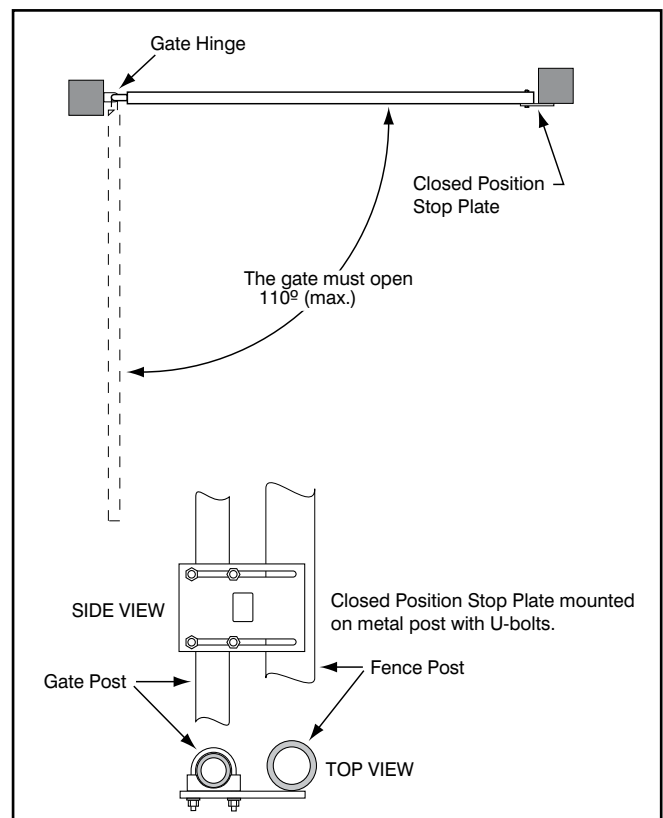

**At this stage of the installation, the operator should be installed on the gate and the closed position stop should be in place.**

**Check List**

- The gate is plumb, level, and swings smoothly on its hinges.
- A plate or support was added for the gate bracket (if necessary).
- The operator is level and mounted on the centerline of the gate.

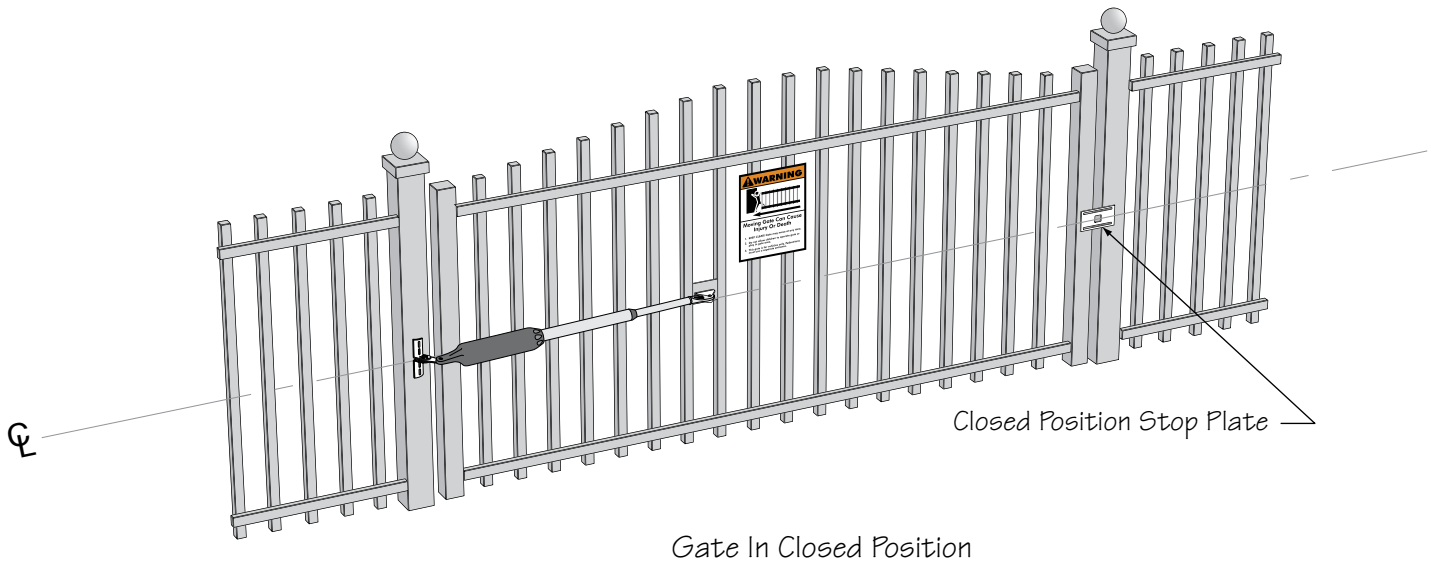

## Mounting the Control Box

### Step 13

Mount the control box using the screws (*provided*) or another secure mounting method. The control box must be mounted at least **3 feet above the ground** to protect it from rain splash, snow, etc., and at least **3 feet from an AC power source** to prevent electrical interference.

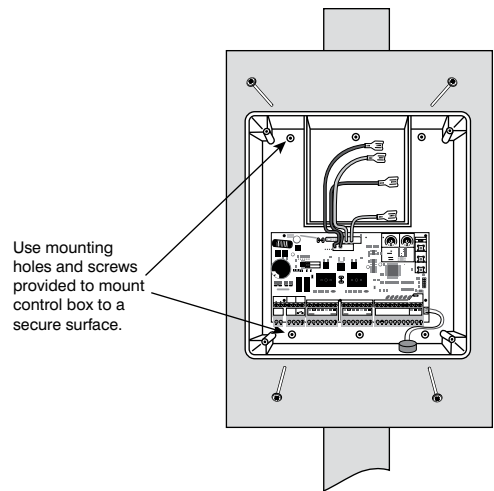

**NOTE:** The battery that came with your GTO/PRO® 3000XL **MUST** be placed horizontally battery with the terminals on the **RIGHT**. If an optional second battery is needed, both batteries must be placed vertically with terminals at the bottom. A second battery is recommended for solar and/or high traffic applications.

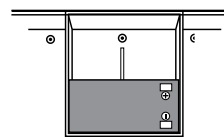

**Single Battery**  
Installed Horizontally  
with terminals on the right.

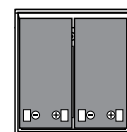

**Dual Batteries**  
Installed Vertically  
with terminals on bottom.

# Connecting Opener Power Cable

## Step 1

Make sure the control box power switch is in the **OFF** position. The ON/OFF Switch is located on the bottom of the control box. Remove the control box cover and slide the battery into position with its terminals to the **RIGHT** (see illustration). Connect the **BLACK** battery wire to the **NEGATIVE (-)** battery terminal. Connect the **RED** battery wire to the **POSITIVE (+)** terminal. *Pay close attention to the color of the wires. If the wires are connected incorrectly, the control board will be damaged. NEVER insert the battery with the terminals to the left.*

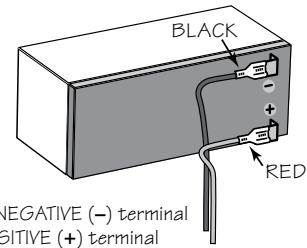

BLACK wire to NEGATIVE (-) terminal  
RED wire to POSITIVE (+) terminal

## Step 2

Strip approximately  $\frac{3}{16}$ " of insulation from each wire of the opener power cable. Twist each exposed wire tightly (there are seven [7] wires inside the power cable sheath). Loosen sealing nut on strain relief hub at bottom of control box. Insert power cable into control box through strain relief. Thread approximately 6" of the power cable into the control box and retighten sealing nut until the power cable locks into place.

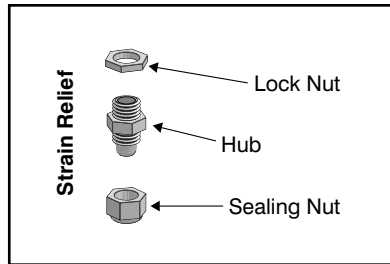
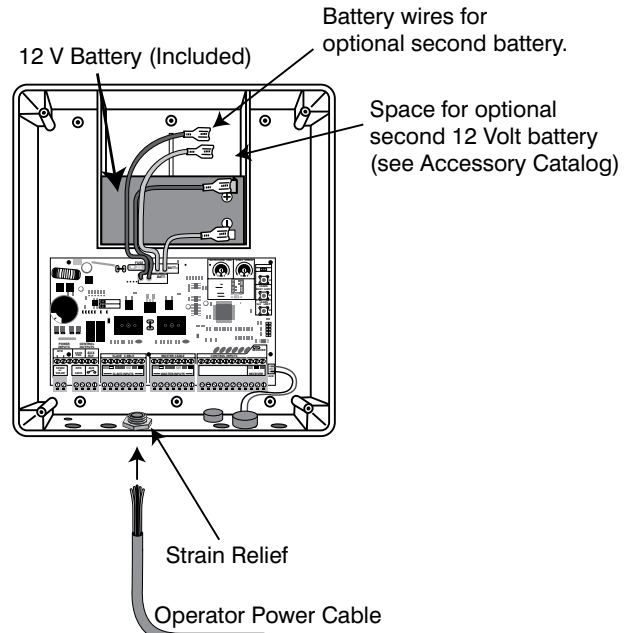

## Step 3

Insert the stripped power cable wires into the appropriate terminals on the **MASTER INPUTS** terminal block. The green wire should be inserted into the **GRN** terminal, the white wire into **WHT**, the blue wire into **BLUE**, brown wire into **BRN**, and the orange wire into the **ORG** terminal, red wire into **RED**, and black wire into **BLK**.

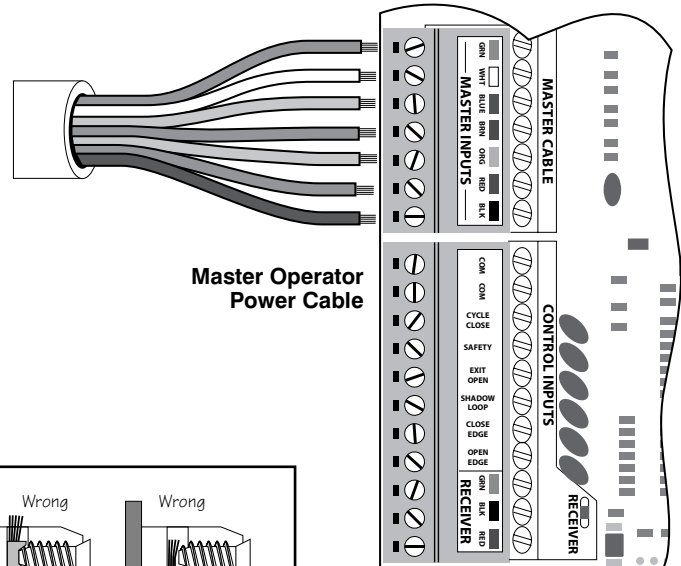

Tighten the set screws against the end of the wires. A dab of petroleum jelly on each terminal will help prevent corrosion.

**NEVER splice wires together. Splicing permits corrosion and seriously degrades the wire's ability to carry an adequate current.**

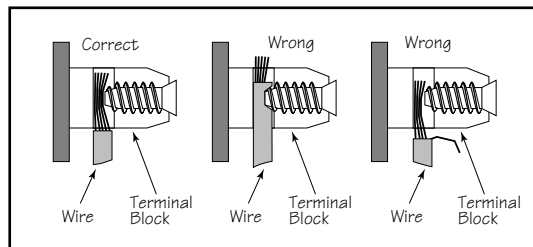

# Powering the System

## Optional Solar Panels and Gate Activity

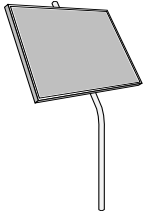

The table and map illustrate the maximum number of gate cycles to expect per day in a particular area when using from 5 to 30 watts of solar charging power. (see *Accessory Catalog*).

The figures shown are for winter (minimum sunlight) and do not account for the use of any accessory items. *Accessories connected to your system will draw additional power from the battery.*

*NOTE: A minimum of 5 watts solar charging power is needed to charge the battery. A second battery is recommended for dual, solar and/or high traffic applications. Consult solar panel installation instructions for further information.*

Winter Ratings	Zone 1	Zone 2	Zone 3
12 v single gate (10 watts) solar charger	8	16	26
12 v single gate (15 watts) solar charger	11	20	30
12 v single gate (20 watts) solar charger	14	28	38
12 v single gate (25 watts) solar charger	17	36	46
12 v single gate (30 watts) solar charger	20	44	54

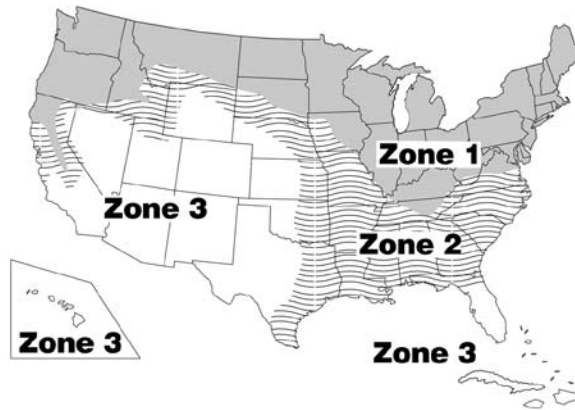

### IMPORTANT:

- If your gate is more than 1000 ft. from an ac power source, you will need to use at least one 5 watt Solar Panel to charge the battery (see *Accessory Catalog*). Refer to the **Solar Panels and Gate Activity** chart above.
- The transformer is designed and intended for indoor use. If the transformer can be plugged only into an outside electrical outlet, a weatherproof cover or housing (available at local electrical supply stores) **must** be used.
- All low voltage wire used with the GTO PRO® Gate Opener must be 16 gauge dual conductor, multi-stranded, direct burial wire (see *page 20* and the *Accessory Catalog*). **Do not run more than 1000 feet of wire.**

## Installation of the Transformer

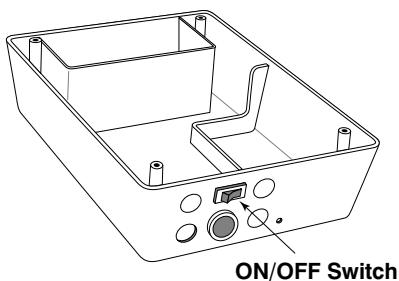

### Step 1

Make sure the power switch is **OFF** before proceeding to the next step.

### Step 2

Select the electrical outlet into which you will plug the transformer. Measure the distance from this outlet to the control box following the path where the wire will be laid. After you have measured how much wire is needed, cut the wire to the appropriate length.

## IMPORTANT INFORMATION ABOUT LOW VOLTAGE WIRE

The only wire acceptable for use with GTO products is 16 gauge multi-stranded, low voltage, PVC sheathed wire. This particular gauge enables the transformer to provide an adequate charge through the control board to the battery at distances up to 1000 ft.

**DO NOT** use telephone wire or solid core wire. Unlike multi-stranded wire, these types of wire are inadequate for use with your gate opener system. Telephone wire and solid core wire do not deliver enough voltage for your gate opener to function and will cause the system to go into a condition known as "low voltage lockout."

**NEVER** splice wires together. Splicing permits corrosion and seriously degrades the wire's ability to carry an adequate current.

### Step 3

Lay the measured length of low voltage wire in a trench following a path from the selected electrical outlet to the control box. Wires coming up from the ground should be run through PVC conduit to protect them from lawn mower blades, weed eaters, and grazing animals. Be sure to bury the wire laid in the trench.

### Step 4

Feed the low voltage wires upward through the strain relief opening on the lower left of the control box. Pull 6" to 8" of wire into the control box.

**⚠ WARNING! DO NOT PLUG THE TRANSFORMER INTO AN OUTLET DURING THIS STEP! THE TRANSFORMER MUST ONLY BE PLUGGED INTO AN OUTLET DURING STEP 7!**

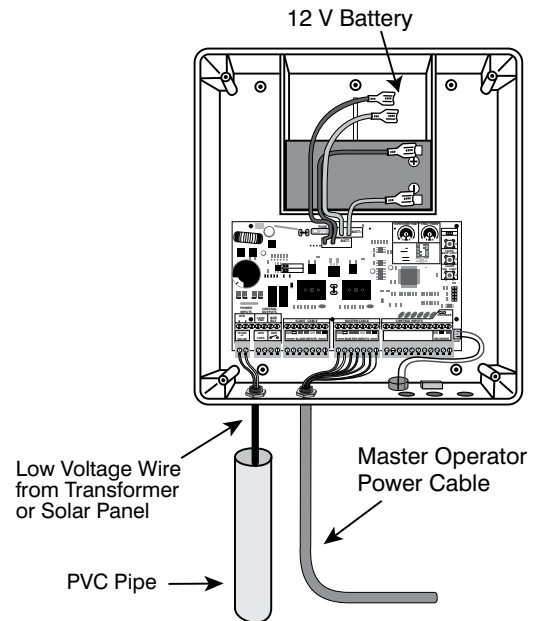

### Step 5

Strip  $\frac{3}{16}$ " off the ends of the low voltage wire and twist tightly. Attach these ends to the **GTO TRANSF** (GTO Transformer) terminals located on the **POWER INPUTS** (GTO Transformer) terminal block (*see illustration at right*). **Be certain not to let the exposed wires touch each other!**

Insert one transformer wire into an **GTO TRANSF** terminal. Insert the other transformer wire into the remaining **GTO TRANSF** terminal. The transformer wires can be connected to the **GTO TRANSF** terminals regardless of color or polarity.

Tighten set screws against exposed end of wires. A dab of household petroleum jelly on each terminal will help prevent corrosion.

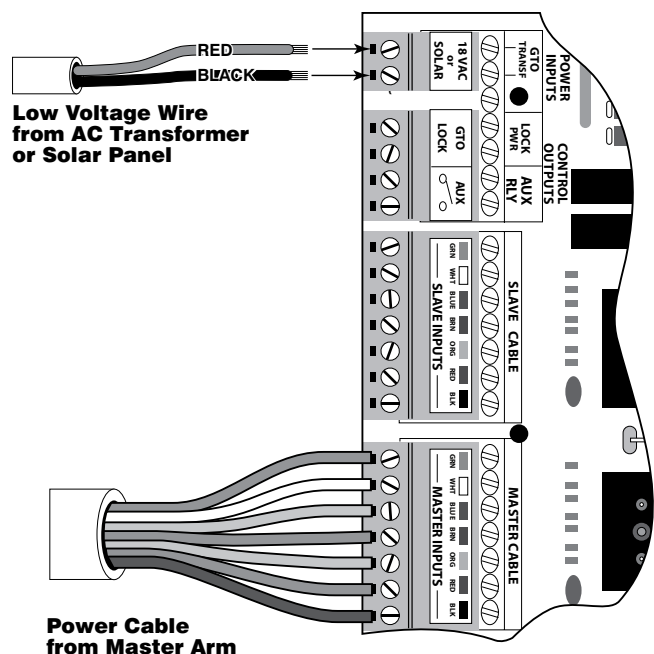



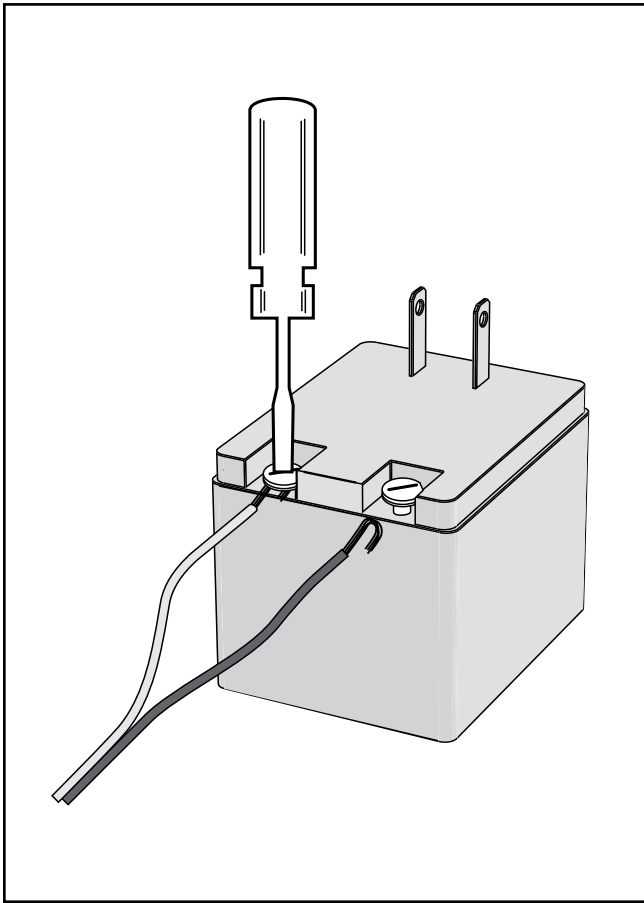

## Step 6

Strip 1/2" of insulation from the ends of the low voltage wire. Attach these stripped ends to the transformer terminals.

A dab of household petroleum jelly on each terminal will help prevent corrosion.

**Make sure the exposed wires do not touch each other!**

## Step 7

Plug the transformer into the electrical outlet.  
(Use of a surge protector with the transformer is strongly recommended.)

**NOTE: This is a class II indoor transformer.**

**IMPORTANT:** If using transformer outdoors be sure to enclose it in a weatherproof case.

**HINT:** Keep a few mothballs in the control box to discourage insects from entering it and damaging the control board.

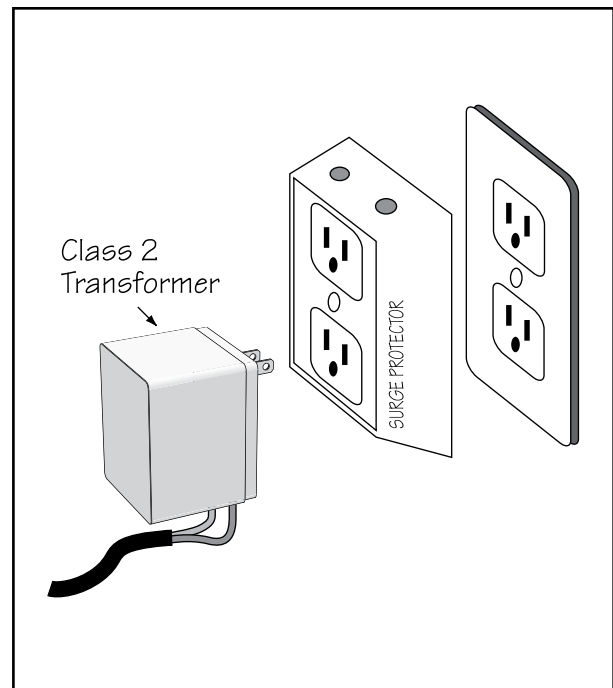

# CONTROL BOARD SETTINGS

## DIP Switches

### Main DIP Switch Settings (MODES)

#### DIP Switch #1 - Soft Start/Stop

**ON** - Soft start enabled (factory preset).

**OFF** - Soft start disabled.

The Soft Start/Stop feature slowly starts the gate as it begins to open and slows the gate as it comes to the closed position. This saves wear and tear on the gate and gate opener system.

#### DIP Switch #2 - Warning Buzzer

**ON** - Buzzer warning enabled (factory preset).

**OFF** - Buzzer warning disabled.

The Warning Buzzer alerts you when the gate opener is beginning to either open or close the gate. It sounds for the first 2 seconds in each direction. It also sounds a warning when the gate obstructs two times in one cycle. Switching this to OFF only disables the open and close warning not the obstruction warning.

#### DIP Switch #3 - Push/Pull-to-Open

**ON** - Push to open.

**OFF** - Pull to open (factory preset).

If your gate opens into the property the DIP Switch is set to the OFF position (factory setting). If your gate opens out from the property the DIP Switch must be set to the ON position.

NOTE: if you have a Push-to-Open gate application you will need a Push-to-Open bracket (see Push-to-Open Instructions on page 30).

#### DIP Switch #4 - Dual Operation

**ON** - Slave opens simultaneously with master.

**OFF** - Slave opens after master.

Note: Not applicable for single gate operator.

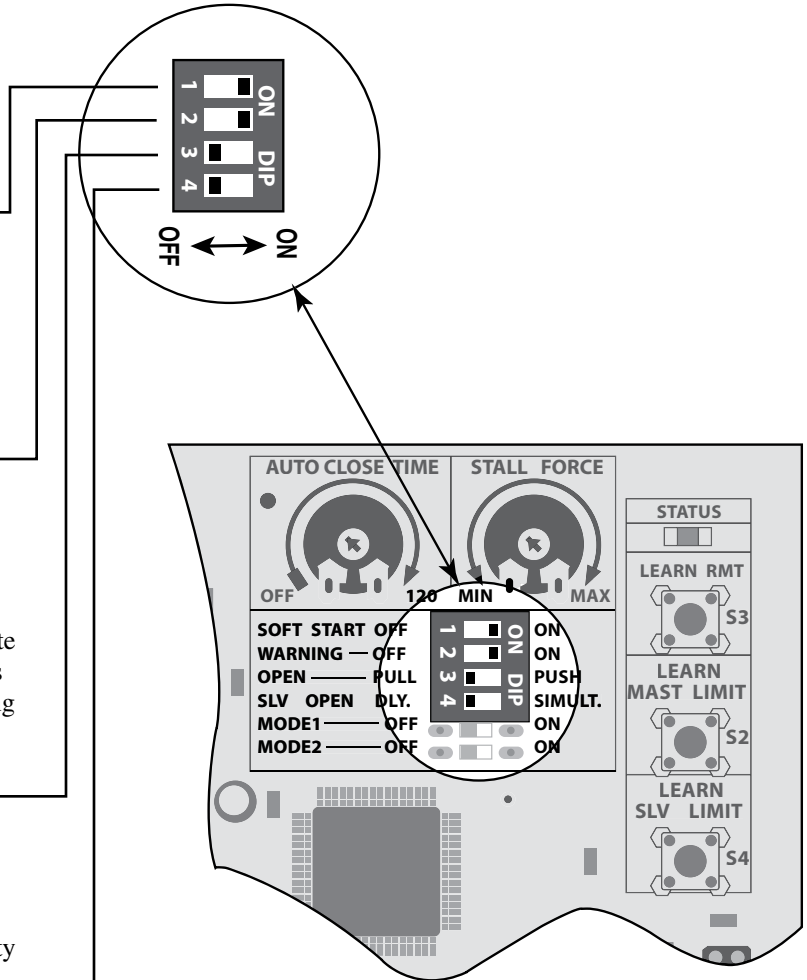

## Auto Close

The 'AUTO CLOSE TIME' potentiometer controls auto close feature.

Turning the potentiometer all the way counter-clockwise will turn auto close feature off. The minimum auto close time is 3 seconds. The maximum (turn the potentiometer all the way clockwise) auto close time is 120 seconds.

Auto Close Time Potentiometer

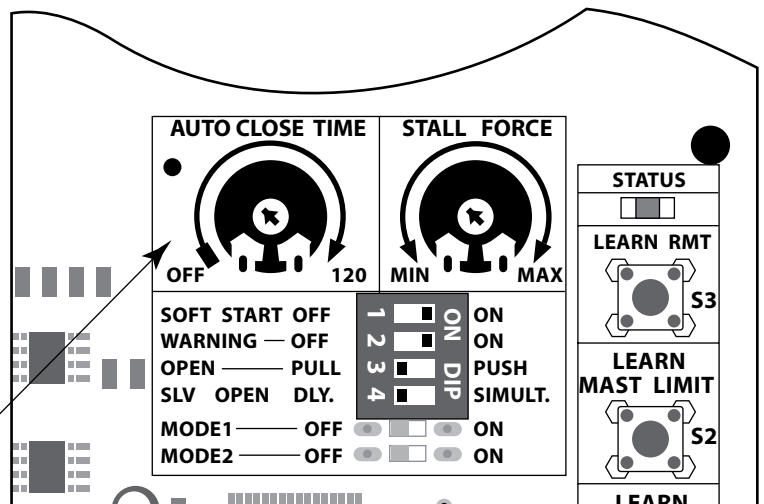

# Setting the Closed Position Limit for Pull to Open Applications

**NOTE:** For heavier gates you may need to increase the stall force (see pg 24). If the gate still does not open or close to the limits you have set, check to ensure that the gate installation was performed correctly according to the guidelines set forth on page 11. If the transmitter does not activate the gate operator you may have to reset the transmitter code (see pg 25).

## TURN CONTROL BOX ON

### Your GTO PRO® has two Limit Settings

1) **OPEN Limit setting:** (Gate in the OPEN POSITION / the limit is FACTORY SET and NOT ADJUSTABLE)  
The open limit setting is the fully open position. The tube on the operator arm must be fully retracted.

2) **CLOSED Limit setting:** (Gate in the CLOSED POSITION) To achieve optimum closed position, you are required to complete the following FOUR STEPS:

### Step 1

Confirm that the power switch is in the ON position and the gate is in the OPEN POSITION.

### Step 2

Activate your opener by pressing the entry transmitter button. Your gate should now be moving from the fully open position toward the closed position. Prepare to STOP the gate by pressing the entry transmitter button again when the gate reaches the desired closed position. This step may be repeated until desired close position is achieved. Once the desired CLOSED position has been achieved, proceed to step 3.

### Step 3

With the gate in the desired closed position PRESS & HOLD the "LEARN MAST LIMIT" button on the control board for 5 seconds.

### Step 4

Press the transmitter button and allow the gate to return to the fully open position. YOUR GATE'S CLOSED POSITION LIMIT IS NOW PROGRAMMED.

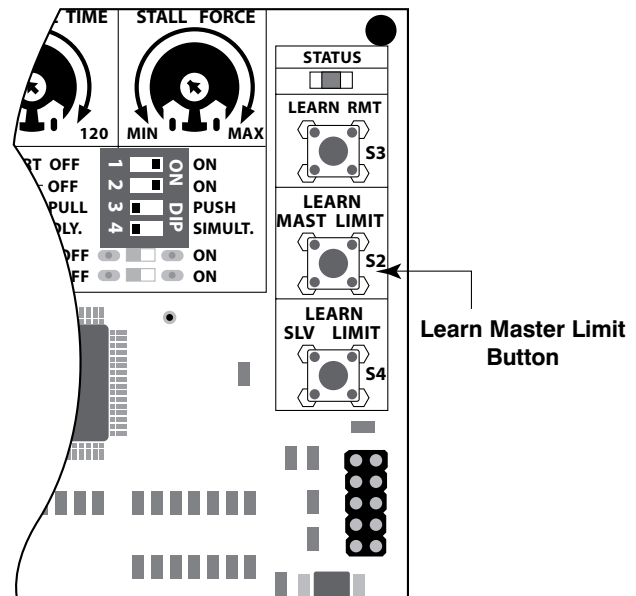

### TESTING YOUR CLOSED LIMIT SETTING:

Press your entry transmitter and allow your gate to close. If the CLOSED position is not correct or needs to be changed, you will need to CLEAR your CLOSED LIMIT settings and follow Steps 1-4 again.

### CLEARING THE PROGRAMMED CLOSED LIMIT SETTING:

If you make a mistake and set the limit at the wrong position – press your transmitter to return the gate to the fully opened position, then press and hold the "LEARN MAST LIMIT" button for 5 seconds. This will clear the memory for the closed limit position. Follow Steps 1-4 again.

# Obstruction Sensitivity Potentiometer

**IMPORTANT:** For safety reasons the obstruction setting or **Stall Force** on the GTO PRO® control board comes from the factory set at **MIN** (minimum). In many gate installations this setting will need to be adjusted to overcome the weight and size of the gates.

The **Stall Force** potentiometer on the control board operates like a volume control on a radio. It controls the obstruction sensitivity (or the amount of force the opener will apply to an obstruction) before it automatically stops and reverses direction for approximately two (2) seconds.

Use a small slotted screwdriver to turn the arrow in the center of the potentiometer. Adjust the stall force from the **MINIMUM** position where the gate operates without obstructing from its own weight or the wind conditions in your area.

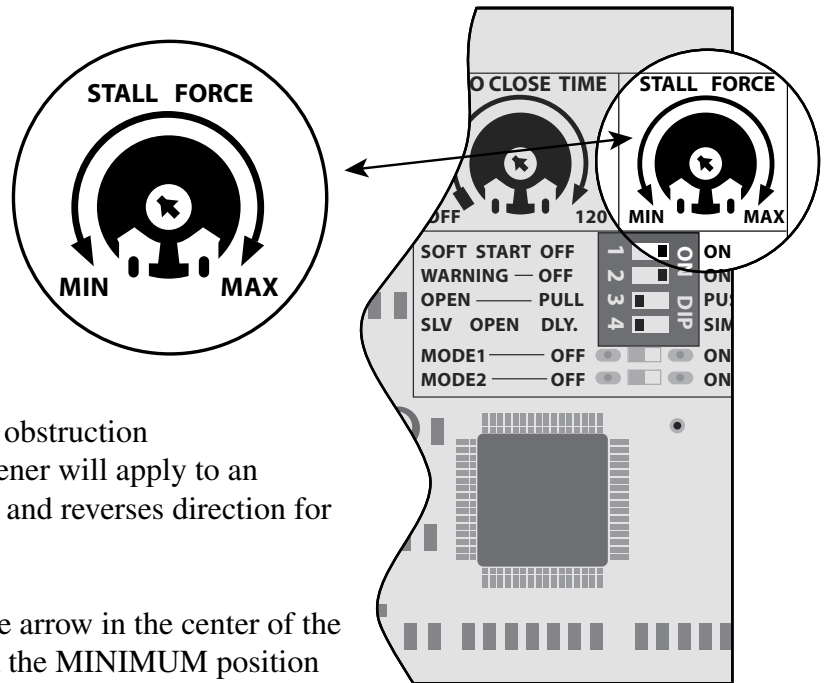

**ALWAYS KEEP SAFETY AT THE TOP OF YOUR LIST WHEN ADJUSTING OR SERVICING YOUR AUTOMATIC GATE OPENER!**

# Setting Your Personal Transmitter Code

All GTO transmitters are set to a standard code at the factory and are ready to operate your GTO PRO® Gate Opener®. For your safety and security, however, we **strongly recommend** that you replace the factory setting with your own personal code. Follow the directions below:

## 1. Remove the Transmitter Cover

On the back of the transmitter use a small phillips head screw driver to remove the two screws on the sides of the visor clip and separate the front cover from the transmitter. With the front cover removed, the battery and the DIP switches will be exposed. To set a new code, use a small screwdriver to move the switches.



## 2. Set the transmitter DIP Switches

There are nine (9) transmitter DIP switches; each can be placed in three different positions (+, 0, -). **DO NOT** set all the switches in the same position, such as all +, all 0, or all -. Once the DIP switches have been set to a personal code, replace front cover.

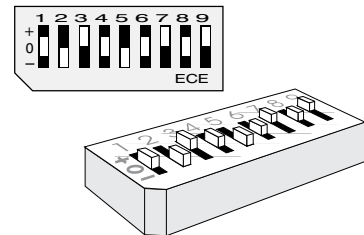

**WARNING:** No other adjustments should be made inside the transmitter.

## 3. "Teach" the New Code to Control Board Memory

- Press and hold transmitter button.
- Press and hold the **LEARN RMT (Learn Remote)** button on the control board until the buzzer sounds.
- Release transmitter button. The new code is stored in control board memory.
- Release the **LEARN RMT (Learn Remote)** button.

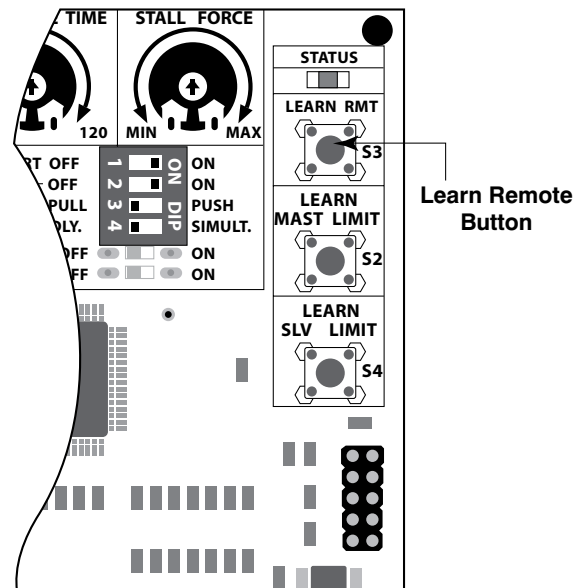

# Installing the Receiver

Use the transmitter to check the range of the receiver *before permanently mounting it*.

Consider the following when mounting the receiver:

- Standard receiver cable length is 10 feet (receivers with a longer cable are available as special order items; *call the GTO Sales Department*). NEVER splice receiver cable!
- **Run the cable through PVC conduit to protect it from damage.**
- DO NOT run cable through metal conduit because the receiver signal range will be decreased.
- DO NOT run cable in conduit containing ac wiring.
- The receiver range can vary from 50 to 100 feet depending upon weather, topography, and external interference.
- DO NOT mount upside down.
- DO NOT mount on metal fence or post; doing so will decrease signal range.
- MOUNT so that you have line of sight between remote to antenna.
- MOUNT 3 feet away from AC voltage.
- MOUNT as high as possible for optimum range.

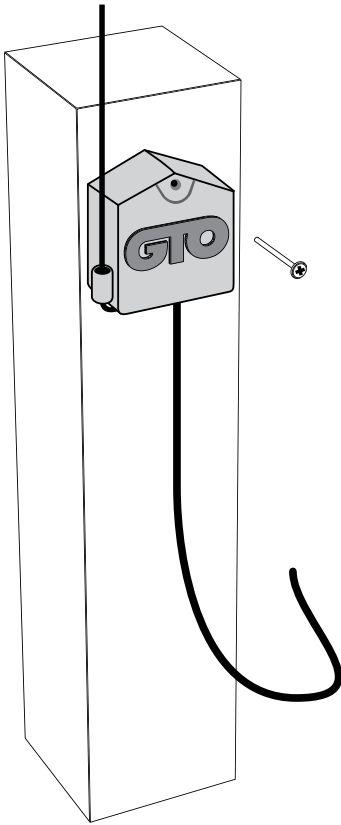

## FCC Regulation

This device complies with FCC rules Part 15. Operation is subject to the following conditions:

1. This device may not cause harmful interference.
2. This device must accept an interference that may cause undesired operation.

Transmitter distance may vary due to circumstances beyond our control. **NOTE:** **The manufacturer is not responsible for any radio or TV interference caused by unauthorized modifications to this equipment. Such modifications could void the user's authority to operate the equipment.**

# Connecting Accessories

## Input Connections

**NOTE:**

- All control inputs are dry-contact, normally open, inputs. DO NOT apply external voltage sources to these inputs.
- All inputs are connected with respect to **COMMON** terminal.
- The status LED will blink once when its corresponding input is activated.

- 1 COM:** Circuit common (reference for all logic input)

  - Two (2) terminals to provide extra common connection point.
- 2 CYCLE CLOSE:** (Typically for use with doorbell button or hardwired key pad)

  - Each activation at this input will cycle the operation as follows:  
.... OPEN STOP CLOSE STOP OPEN ...
- 3 SAFETY:** (Typically for use with photo beam device, loop detector or other non-contact sensors)

  - Activation of this input while the gate is closing will cause the gate to stop and return to the opened position.
  - Activation of this input while the gate is opening has no effect (gate will continue to open).
  - Activation of this input while gate is idle will prevent gate from closing.
- 4 EXIT/OPEN:** (Typically for use with exit loop or wand)

  - Activation of this input will open the gate if it's not already at the open position
  - Activation of this input while at open limit will restart the auto close time (if enabled).
- 5 SHADOW LOOP:** (Typically for use with loop detector device)

  - This input is only monitored when the gate is at the fully open position. At any other position, activation of this input has no effect on gate operation.
  - Activation of this input while gate at the fully open position will prevent gate from closing.
- 6 CLOSE EDGE:** (Typically for use with safety edge device)

  - Activation of this input while the gate is closing will cause the gate to stop and reverse direction for approximately 2 seconds.
  - Activation of this input while the gate is opening has no effect (gate will continue to open).
  - Activation of this input while gate is idle will prevent gate from closing.
- 7 OPEN EDGE:** (Typically for use with safety edge device)

  - Activation of this input while the gate is opening will cause the gate to stop and reverse direction for approximately 2 seconds.
  - Activation of this input while the gate is closing has no effect (gate will continue to close).
  - Activation of this input while gate is idle will prevent gate from opening.

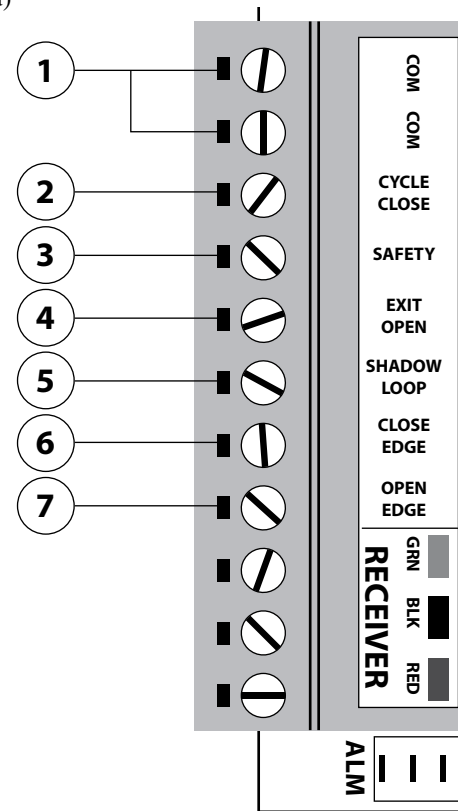

# Connecting Accessories

## Wiring Accessories

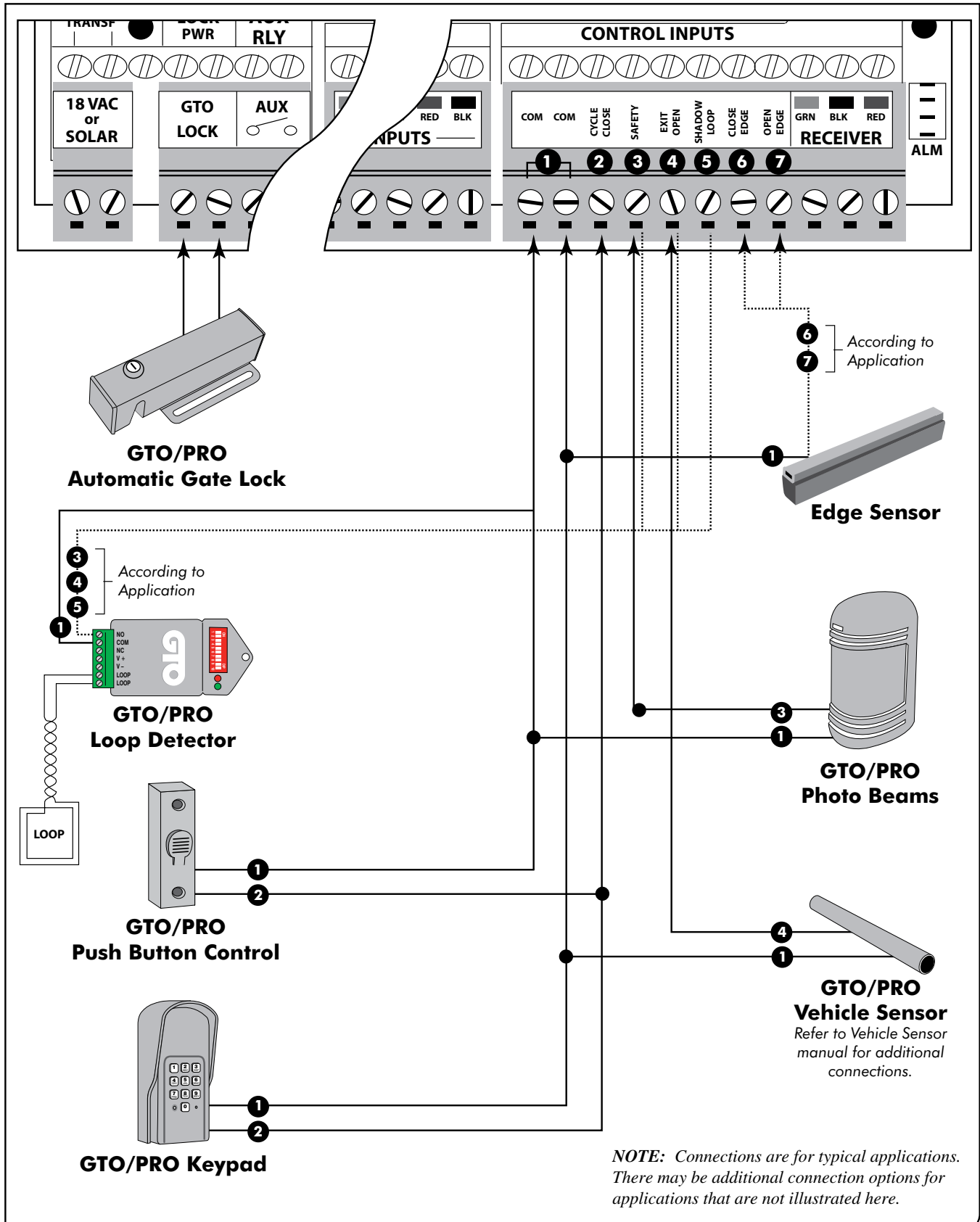



# Connecting Other Auxiliary Devices (Mag Locks, Sirens, Lights, etc.)

- These 2 terminals are normally open 'dry-contact' (no voltage) relay output.
- These 2 terminals are ON (shorted) whenever the gate is moving and OFF (opened) otherwise.
- These 2 terminals maximum rating is 24Vdc, 1 Amp.

## Push to Open Installation

### Determining The Mounting Position of The Post Bracket Assembly

**⚠** Swinging gates shall not open into public access areas!

A "Push-to-Open" gate opens *out* from the property. A **Push-to-Open Bracket** is required for this type of installation (see *Accessory Catalog*). If you have a pull-to-open gate (gate opens *into* the property), return to page 13; step 3.

In a PUSH-TO-OPEN installation the openers are installed while the gates are in the **closed** position.

#### Step 1

With the gates **closed**, adjust the post bracket assembly and the gate bracket until the opener is level. While holding the opener level, use C-clamps to temporarily keep the post bracket assembly and gate bracket in their respective positions on the fence post and gate.

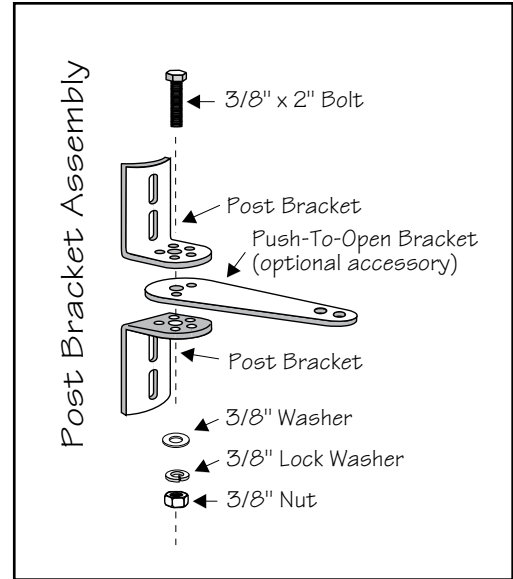

**IMPORTANT:** While determining the mounting point for the post pivot bracket assembly be sure that the position allows for maximum clearance between the gate and the opener in both the open and closed positions, as shown in the diagrams below. This clearance will give the opener the most efficient leverage point for opening and closing the gate and more importantly provides the least possible pinch area.

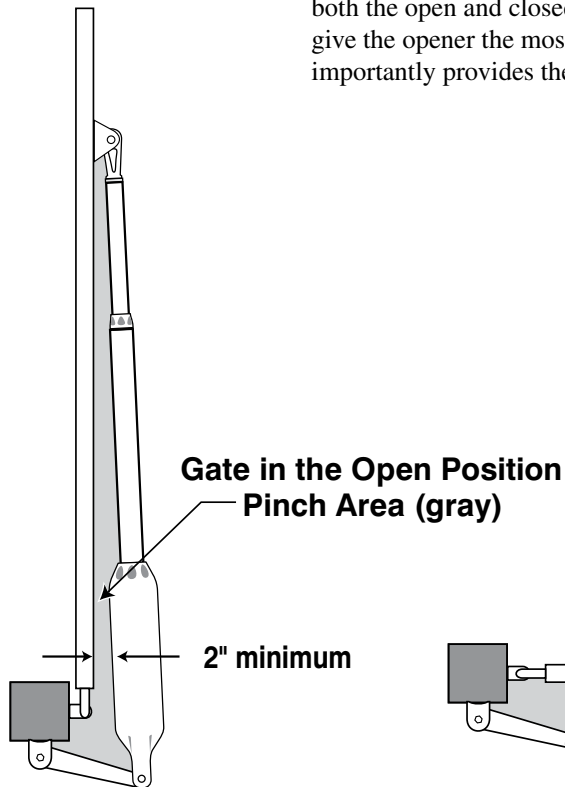

#### Step 2

After verifying that you have the best position for the post pivot bracket, insert the  $\frac{5}{16}$ " x  $1\frac{3}{4}$ " bolt through the aligned holes of the post bracket and post pivot bracket and fasten it with the  $\frac{5}{16}$ " washer and nut.

**IMPORTANT:** If you loosened the clamp on the post bracket to achieve the optimum position, tighten it in its new position and recheck the gate bracket with the gate in the open position (move the gate bracket and re-clamp it if necessary).

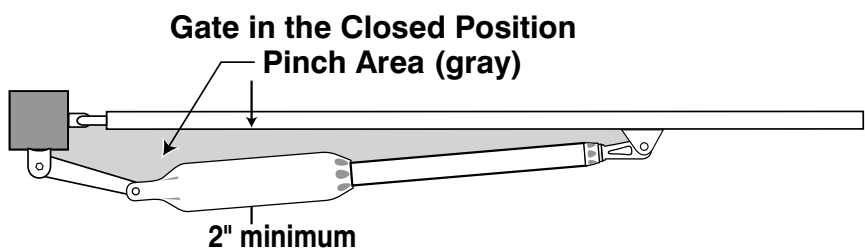

# Push to Open Installation

## Step 3

With the gate in the **fully closed position** and the opener retracted, align the opener to the gate. Mark reference points for bolt holes on gate cross member through middle of gate bracket slots. The opener must be level. (Some vertical adjustment is possible by sliding the post bracket assembly up and down.) Drill  $\frac{3}{8}$ " holes into the gate cross member as marked. Fasten gate bracket to cross member using (2)  $\frac{3}{8}$ " x 3" bolts, washers, lock washers, and nuts. Attach the opener to the post bracket assembly and gate bracket using clevis pins, bushings, and hairpins clips.

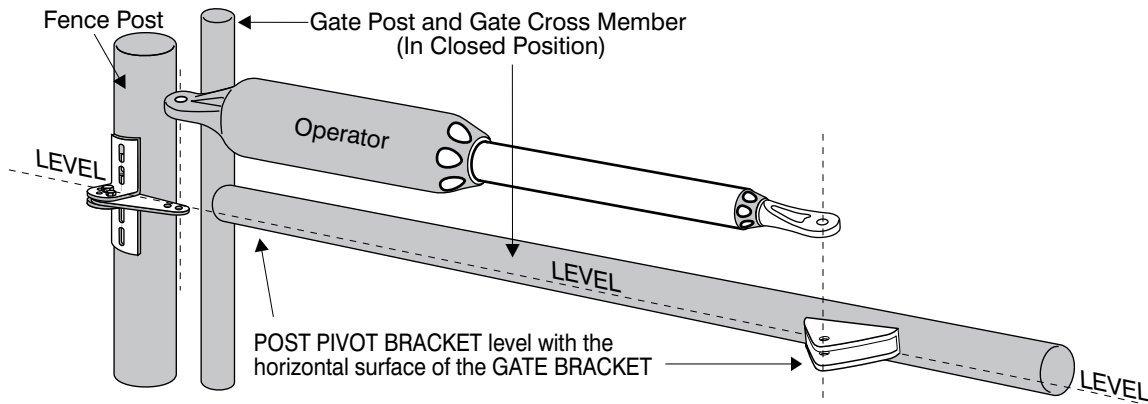

## Step 4

Make sure the control box power switch is **OFF**. Use a small screwdriver to move the **Number 3** DIP switch from the factory setting (OFF / Pull-To-Open) to **ON for Push-To-Open**. Turn power switch **ON**. The control board is now configured to *push* the gate open.

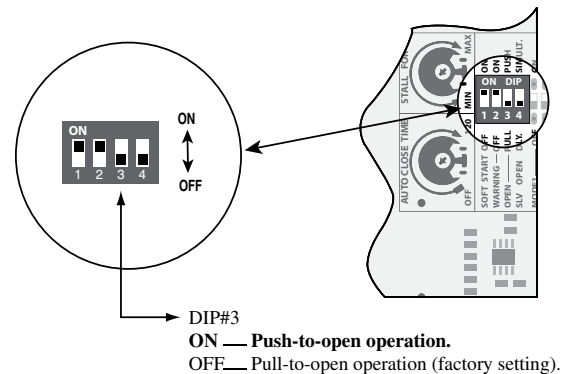

# Setting the Open Position Limit

## Step 1

Confirm that the power switch is in the ON position, and the gate is in the CLOSED POSITION.

## Step 2

Activate your opener by pressing the entry transmitter button. Your gate should now be moving from the closed position toward the open position. Prepare to **STOP** gate by pressing the entry transmitter button again when the gate reaches the desired open position. This step may be repeated until desired open position is achieved. Once the desired **OPEN** position has been achieved, proceed to Step 3.

### Step 3

With the gate in the desired open position PRESS & HOLD the "LEARN MAST LIMIT" button on the control board for 5 seconds.

### Step 4

Press the transmitter button and allow the gate to return to the closed position. YOUR GATE'S OPEN POSITION LIMIT IS NOW PROGRAMMED.

#### TESTING YOUR OPEN LIMIT SETTING:

Press your entry transmitter and allow your gate to open. If the OPEN position is not correct or needs to be changed, you will need to CLEAR your OPEN LIMIT settings and follow steps one (1) to four (4) again.

#### CLEARING PROGRAMMED OPEN LIMIT SETTING:

If you make a mistake and set the limit at the wrong position – press your transmitter to return the gate to the fully closed position, then press and hold the "LEARN MAST LIMIT" button for 5 seconds. This will clear the memory for the

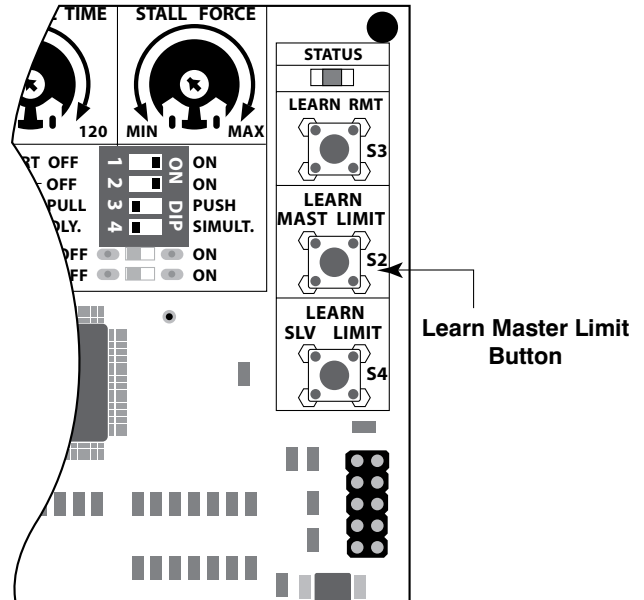

# Troubleshooting Guide

If your gate opener does not function properly after it is installed, use this guide before calling the GTO Service Department.

## Generation 3 Audible Feedback

Symptom	Diagnosis	Check:
1 short beep upon activation	Blown Fuse Low or Bad Battery Loose Battery Connection	<ul style="list-style-type: none"> <li>• Fuse</li> <li>• Battery Under Load</li> <li>• Battery Harness Connections</li> </ul>
1 short beep upon power up	Circuit Board Powered Up & Ready	<ul style="list-style-type: none"> <li>• Normal Operation</li> </ul>
Continuous Uninterrupted Alarm	Circuit Board Senses an Obstruction	<ul style="list-style-type: none"> <li>• Path of Gate</li> <li>• Gate for Level and Plumb</li> <li>• Stall Force Adjustment</li> <li>• Disconnect Safety Devices</li> <li>• Rev Counter</li> </ul>
1 beep with 10 seconds off	Low Battery Condition	<ul style="list-style-type: none"> <li>• Fuses</li> <li>• Battery Harness Connections</li> <li>• Battery Under Load</li> </ul>
1 beep then 2 beeps	Master Motor Terminals Shorted	<ul style="list-style-type: none"> <li>• Connections to Master Inputs</li> <li>• Master Arm Power Cable</li> <li>• Motor</li> <li>• Circuit Board</li> </ul>
1 beep then 3 beeps	Slave Motor Terminals Shorted	<ul style="list-style-type: none"> <li>• Connections to Master Inputs</li> <li>• Master Arm Power Cable</li> <li>• Motor</li> <li>• Circuit Board</li> </ul>
1 beep with 2 seconds off	Master Arm Limit Switch Error	<ul style="list-style-type: none"> <li>• Connections to Master Inputs</li> <li>• Master Arm Power Cable</li> <li>• Master Input ORG &amp; GRN, BRN &amp; GRN voltage with wires disconnected. 11VDC across each terminal.</li> </ul>
2 beeps with 2 seconds off	Slave Arm Limit Switch Error	<ul style="list-style-type: none"> <li>• Connections to Slave Inputs</li> <li>• Slave Arm Power Cable</li> <li>• Slave Input ORG &amp; GRN, BRN &amp; GRN voltage with wires disconnected. 11VDC each across each terminal.</li> </ul>
3 beeps with 2 seconds off	Master Arm Rev Counter Error	<ul style="list-style-type: none"> <li>• Connections to Master Inputs</li> <li>• Master Arm Power Cable</li> <li>• Rev Counter</li> </ul>
4 beeps with 2 seconds off	Slave Arm Rev Counter Error	<ul style="list-style-type: none"> <li>• Connections to Master Inputs</li> <li>• Master Arm Power Cable</li> <li>• Rev Counter</li> </ul>

# Generation 3 Visual Feedback

Symptom	Diagnosis	Check:
Status (clear) 1 blink	Cycle Terminal Shorted	Disconnect the push button, keypad, intercom keypad, or any other accessory wired to this terminal. Try the remote. If the remote works, then the problem is the accessory.
Status (clear) 2 blinks	Safety Terminal Shorted	Disconnect the loop detector, photo beam, or any other accessory wired to this terminal. Try the remote. If the remote works, the problem is the accessory.
Status (clear) 3 blinks	Exit Terminal Shorted	Disconnect exit wand, loop detector, photo beam, Knox box, or any other accessory wired to this terminal. Try remote. If the remote works, the problem is the accessory.
Status (clear) 4 blinks	Shadow Terminal Shorted	Disconnect the loop detector, photo beam, or any other accessory wired to this terminal. Try remote. If the remote works, the problem is the accessory.
Status (clear) 5 blinks	Close Edge Terminal Shorted	Disconnect the edge sensor, photo beam, or any other accessory wired to this terminal. Try the remote. If the remote works, the problem is the accessory.
Status (clear) 6 blinks	Open Edge Terminal Shorted	Disconnect edge sensor, photo beam, or any other accessory wired to this terminal. Try the remote. If the remote works, the problem is the accessory.
RF (yellow) Flickers	Receiving 318 MHz RF	Normal operation when remote or wireless keypad is used.
RF (yellow) OFF	No 318 MHz RF Received	<ul style="list-style-type: none"> <li>• Battery in Remote</li> <li>• Program Remote</li> <li>• Antenna Receiver Connections</li> <li>• Antenna Receiver</li> </ul>
Power (green) ON	AC or Solar Power Present	Normal Operation
Power (green) OFF	No AC or Solar Power	<p><b>Transformer:</b></p> <ul style="list-style-type: none"> <li>• Breaker or GFI</li> <li>• Power at AC outlet.</li> <li>• Output of Transformer.</li> <li>• Voltage on wire at 18 VAC Input</li> </ul> <p><b>Solar:</b></p> <ul style="list-style-type: none"> <li>• Solar Panel Wires Reversed</li> <li>• Weather</li> <li>• Solar Panel Placement</li> <li>• Output of Solar Panel</li> <li>• Voltage on wire at Solar Input</li> </ul>
Charge (red) ON	Fast Charging Mode	Battery Voltage should be ~14.8 VDC when connected to the circuit board
Charge (red) Fast Blinking	Soak Charging Mode	Battery Voltage should be ~14.1 VDC when connected to the circuit board
Charge (red) Slow Blinking	Float Charge	Battery Voltage should be ~13.8 VDC when connected to the circuit board
Charge (red) OFF	Battery Not Being Charged	AC power Transformer Solar Panel – Check Weather Charging Circuit

# Repair Service

If your GTO/PRO® 3000XL Gate Opener is not operating properly, please follow the steps below:

1. First use the procedures found in the *Troubleshooting Guide* (see page 32).
2. If you are unable to solve the problem, call the **GTO/PRO Service Department** at (800) 543-1236, or (850) 575-4144. Refer to the serial number (located on the control box cover) and date of purchase when calling for assistance.
3. If repair or replacement of your gate opener is necessary, the Service Department will assign a **Return Goods Authorization (RGA) number** to you for warranty repair.
4. Securely pack the component(s) authorized for return to the factory. Include a copy of proof of purchase. Write the RGA number issued to you on the outside of the package in **LARGE BOLD PRINT**. Ship the package(s) freight prepaid to: **GTO/PRO, 3121 Hartsfield Road, Tallahassee, Florida, USA 32303.**

**NOTE: Products returned to GTO/PRO without a Return Goods Authorization (RGA) number in LARGE BOLD PRINT on the outside of the package WILL NOT be accepted. Also, items returned to GTO/PRO freight collect WILL NOT be accepted.**

The **GTO, Inc. Technical Service Department** is open  
Monday – Friday 8:00 A.M. – 7:00 P.M. (Eastern Time)  
1-800-543-1236 • FAX (850)575-8950  
e-mail: techsupport@gtoinc.com

### VOLTAGE RATINGS

18 Vac Transformer \_\_\_\_\_ 18.0 to 22.0 Vac, 2200 mA

5 W Solar panel (single) \_\_\_\_\_ 18.0 to 22.0 Vdc 300 mA  
measure voltage at panel and control box.

12 V, 7 amp hour Battery \_\_\_\_\_ 12.0 to 13.5 Vdc 7.0 Ah  
or Two 12V, 7 amp hour Batteries if using solar power

Charging circuit \_\_\_\_\_ 12.0 to 14.8 Vdc  
measure voltage with battery connected

The GTO, Inc. Technical Service Department is open  
Monday – Friday 8:00 A.M. – 7:00 P.M. (Eastern Time)

**Telephone (800) 543-1236**  
**Telephone (850) 575-4144**

**GTO/PRO<sup>®</sup>**  
**PROFESSIONAL ACCESS SYSTEMS**

**Fax (850) 575-8950 • Web site: [www.gtopro.com](http://www.gtopro.com)**

**E-Mail: [techsupport@gtoinc.com](mailto:techsupport@gtoinc.com)**

3121 Hartsfield Road • Tallahassee, Florida, USA 32303  
Telephone GTO Sales: 1-800-543-GATE (4283) or (850) 575-0176 • Fax (850) 580-8816

**[www.gtopro.com](http://www.gtopro.com)**

# Column Installation Information

**IF THIS OPERATOR WILL BE USED WITH GATES THAT ARE MOUNTED ON MASONRY, BRICK, OR ROCK (etc.) COLUMNS:**

**READ THE FOLLOWING CAREFULLY BEFORE PROCEEDING**

- A. The simplest solution is to install the operator in a push-to-open configuration (requires Push-To-Open Bracket, see Accessory Catalog). The minimum clearance is easier to achieve and clearance is no longer a problem, since the operator will be pushing the gate away from the column instead of pulling it toward the column. It is recommended that you place a steel plate between the operator mounting brackets and masonry surface for additional strength.
- B. If a push-to-open installation is impossible due to traffic hazards, terrain, etc., another option is to re-hang the gate. You may hang it on a post, either in the center of the column or at the back corner, or move the gate to the back corner of the columns.
- C. The most difficult solution is to cut a notch in the column to accommodate the operator and power cable. This job is **NOT** for the inexperienced!

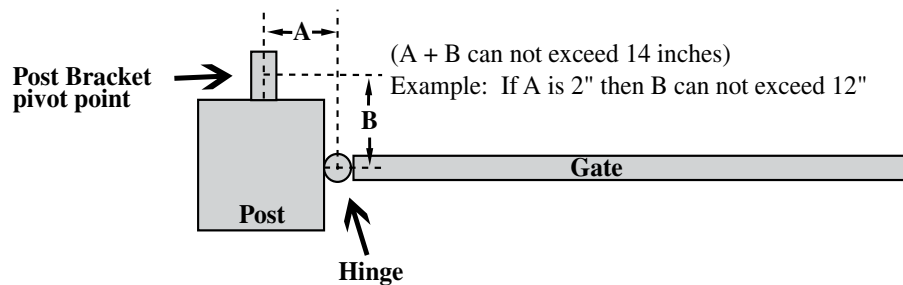





## ACCESSORIES

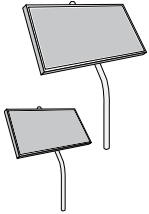

### **Solar Panel (FM123), (FM122)**

The **Solar Panel** is a 10 watt solar powered battery charger for use with the **all GTO/PRO DC** gate operator systems. Particularly suited for remote installations, each **Solar Panel** comes with tubular steel support, mounting clips, wire connectors, and 8 ft. of low voltage wire (see Low Voltage Wire for additional wire). The **GTO/PRO®** control board has clearly labeled terminal connections for easy installation of the **Solar Panel**. Installation in some regions of the world will require multiple solar panels for adequate charging power. **Solar Panel (FM122)** is a 5 watt solar powered battery charger with all the same features as (FM123).



### **Push Button Control (RB101)**

Unlit doorbell button for remote entry or exit control. Wires directly to the control board and uses 16 gauge multi-stranded, dual conductor low voltage wire (sold separately).

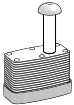

### **Pin Lock (FM345)**

The **Pin Lock** substitutes for the clevis pin at the front end of the **GTO/PRO® 3000XL** gate operator. Helps prevent theft of the operator from the gate, while allowing quick release of the operator.



### **Key Chain Two Button Transmitter (RB742)**

The Key Chain Mini Transmitter is a miniature version of the **GTO/PRO®** entry transmitter and has the same adjustable code settings. 12 Volt battery included.



### **Single Button Transmitter (RB741)**

The **GTO/PRO®** entry transmitter, with adjustable code settings, is standard equipment with all **GTO/PRO®** systems. 12 Volt battery included.

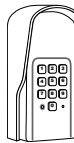

### **Digital Keypad (F310)**

The specially designed digital keypad can be easily installed as a wireless or wired keypad. It can be programmed to use up to 25 different personal identification number (PIN) codes. Each code is face programmable with additional security features built in. Wired installations require 16 gauge, low voltage, multi-stranded, dual conductor, direct burial wire (sold separately). Requires 3 AA batteries (not included).



### **Mounting Post (F100) - In Ground**

This black powder coated pedestal is designed to provide convenient access to your keypad, wireless intercom, or other access control device from your vehicle. With its break down design it is easy to install and works well in most standard applications. Surface Mount Flanges (F102) and Extensions (F103) for added height are available.

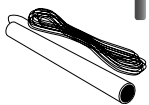

### **GTO/PRO 50' Exit Wand (FM139), 100' Exit Wand (FM140), 150' Exit Wand (FM141)**

The **GTO/PRO®** Exit Wand is designed for residential and agricultural applications and is compatible with all **GTO/PRO®** automatic gate operator models. The wand is an electromagnetic sensor, which offers 'hands free' operation of the **GTO/PRO®** Gate Operators with a 12 ft. radius of detection of vehicles in motion.



### **Automatic Gate Lock Pull-to-Open (FM144)**

A **MUST** for added security. Solenoid driven, with a steel housing. Unlocks and locks automatically as gates open and close. Used with **GTO/PRO®** DC swing gate operating systems for maximum stability and security. Comes with a keyed manual release. Recommended for gates over 8 ft. long. Ideal for animal enclosures or high wind areas.

# ACCESSORIES



## Wireless Entry Intercom / Keypad (F3100MBC)

Allows owner to screen guest at the gate before allowing access to the property. Keypad also allows owner to give up to 25 programmable entry codes to family, friends or approved delivery personnel. Codes can be permanent or temporary. Can be wireless up to 500 feet or hard wired up to 1000 feet. Additional base stations available (F3101MBC).



## Replacement Battery (RB500)

Standard 12 volt, 7.0 amp-hour, maintenance-free battery for the **GTO/PRO® 2500**, **GTO/PRO® 2000XL**, **GTO/PRO® 3000XL**, **GTO/PRO® 4000XL** gate operator systems. This is the only battery approved for use with the **GTO/PRO®** gate operator systems. Life expectancy is 3-5 years.



## Low Voltage Wire (RB509)

The 16 gauge, multi-stranded, dual conductor **Low Voltage Wire** is for connecting the AC powered transformer, or the **Solar Panel** to the control board. Also used for the connection of accessories, such as locks, keypads, push buttons and other wired control devices. This specially designed wire is UV treated, PVC coated and ready for direct burial. Available in 50, 100, 250, 500 and 1000 foot rolls.

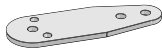

## Push to Open Bracket (347 IH)

Required when **GTO/PRO® 3000XL** gate operator(s) must push the gate open, such as on a sloping driveway or where space prevents gate(s) from opening inward (pulled open). Order two PTO brackets for conversion of a dual swing gate installation.



## Column Mount Lock Receiver (433IH)

For mounting the **Automatic Gate Lock** on brick columns, walls, or for other applications with limited space between gate and post.

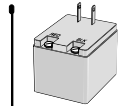

## Replacement Transformer (RB570)

Standard 18 volt, 2200 mA, AC transformer for maintaining the battery included with the **GTO/PRO® 3000XL** gate operator. This is the only transformer approved for use with **all UL325 GTO/PRO®** gate operator systems.



## Garage Door Receiver (RB709U)

The Garage Door Receiver allows you to use the same **GTO/PRO®** entry transmitter (see Dual Transmitter) to operate your gate operator and your garage door operator. Compatible with most garage door operators.

**If you have a question about GTO/PRO accessories  
just call 1-800-543-GATE!**

The contents of all material available on this installation manual are copyrighted by GTO, Inc. ("GTO"), unless otherwise indicated. All rights are reserved by GTO, and content may not be reproduced, downloaded, disseminated, published, or transferred in any form or by any means, except with the prior, written permission of GTO. Any reprinting of GTO publications is by permission only. Copyright infringement is a violation of federal law.

GTO®, GTO/PRO®, Bulldog® are registered trademarks of GTO, Inc. Professional Access Systems™ is a trademark of GTO, Inc. and are the exclusive property of GTO, Inc. ("GTO"). All rights are reserved by GTO, and these marks may not be used, in any for without the prior, written permission of GTO.