

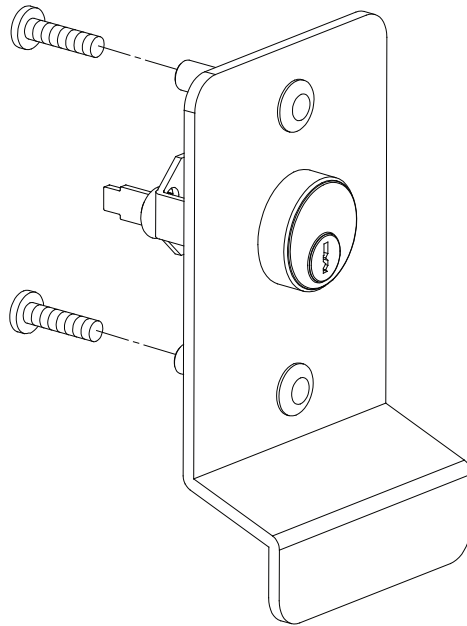

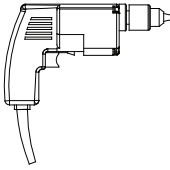



Detex Corporation, 302 Detex Drive, New Braunfels, Texas 78130-3045
(830)629-2900 / 1-800-729-3839 / Fax (830)620-6711
E-MAIL: detex@detex.com INTERNET: www.detex.com

INSTALLATION INSTRUCTIONS FOR 03P/03PN VALUE SERIES TRIM

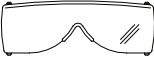

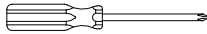
03 PORTLAND Trim

Tools Required	
Power Drill 	Pencil 
	Hammer 
Safety Glasses 	Tape Measure 
Screw Driver 	Center Punch 

Preparing the Trim

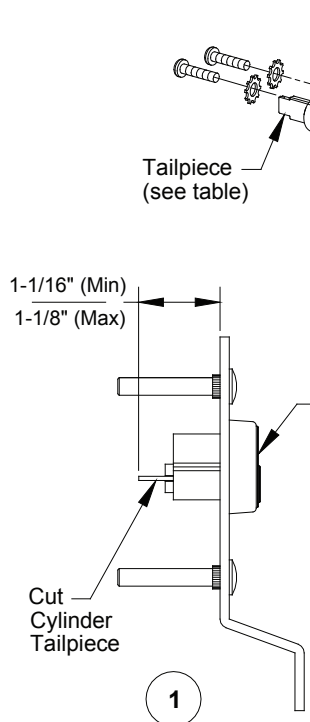

1-1/16" (Min)
1-1/8" (Max)

Cut Cylinder Tailpiece

1

Rim Cylinder Preparation

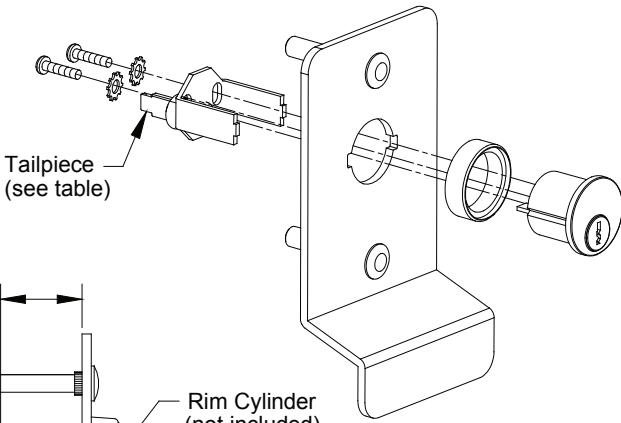



Tailpiece (see table)

Rim Cylinder (not included)

2

Install Tailpiece Assembly

Tailpiece Used	Door Thickness
	1-3/4" and 2" Thick Doors
	2-1/4" Thick Doors

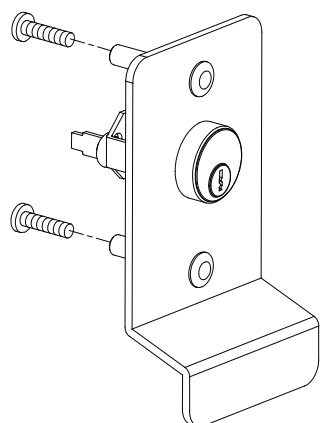

3

Install Trim Unit on Door
(see next page)

Door Preparation

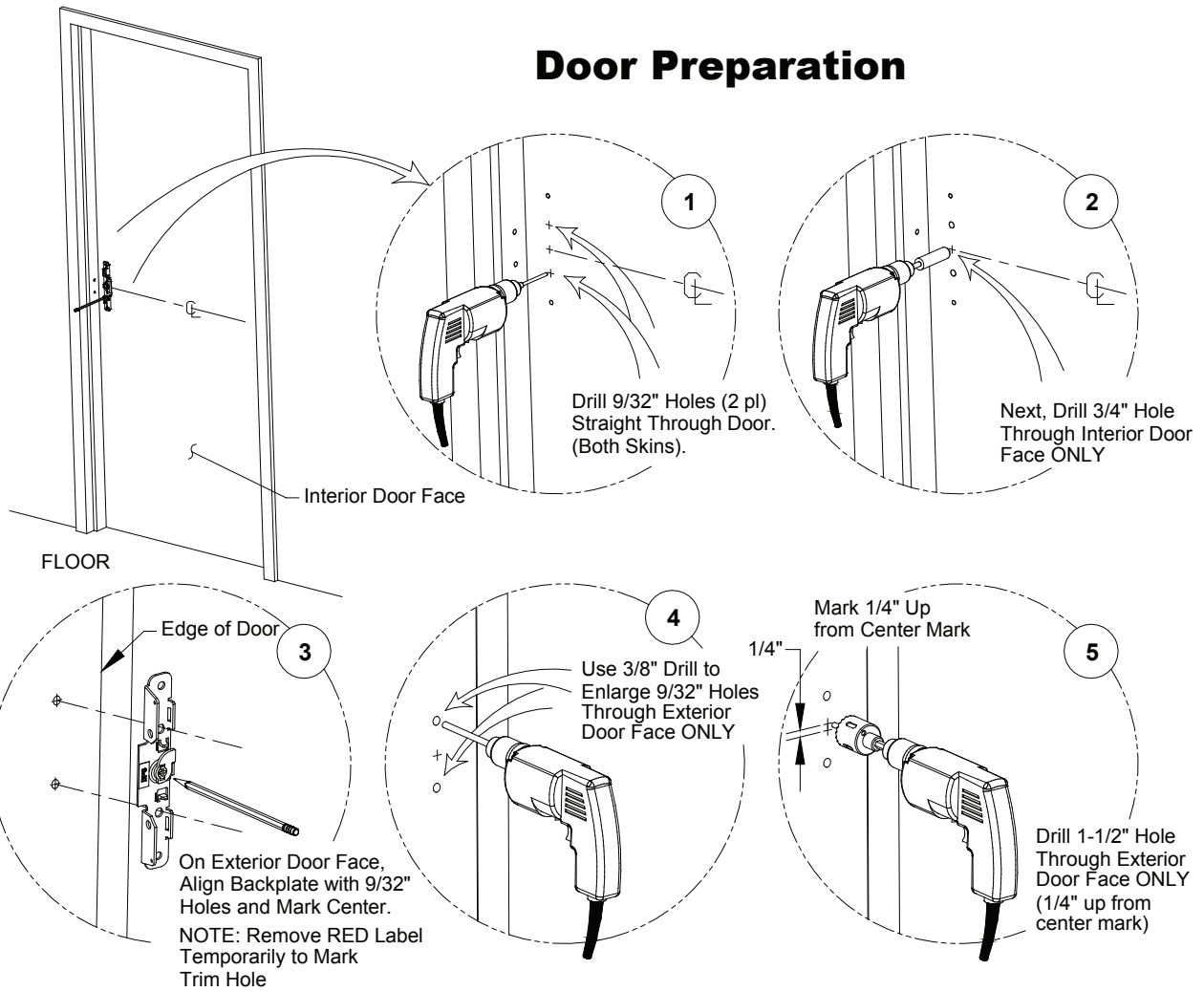

Installing the Trim

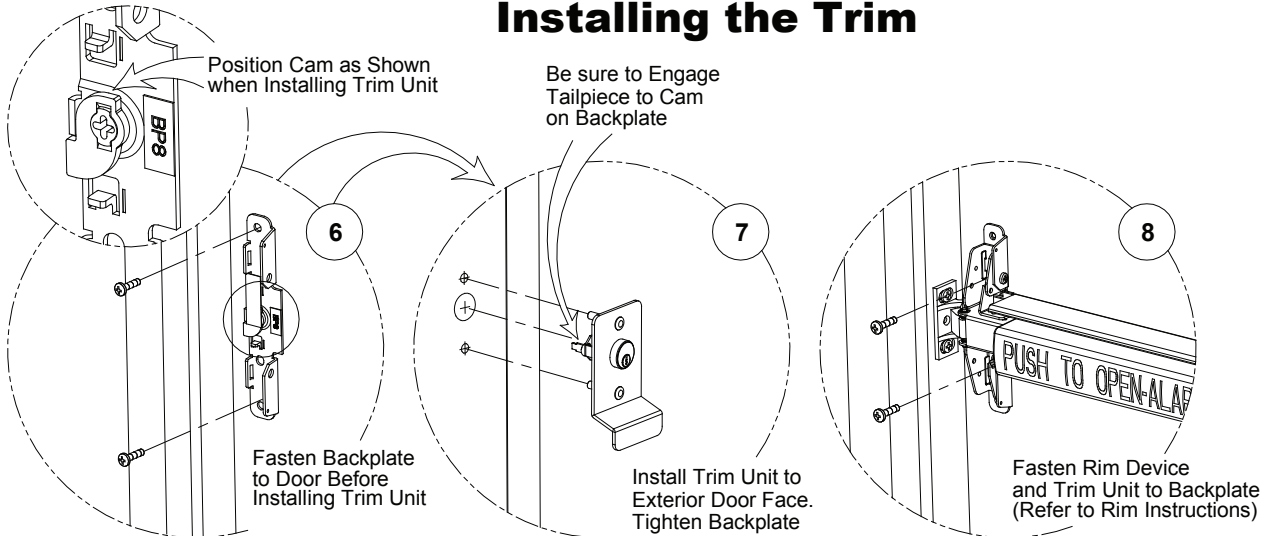

Testing the Trim Installation

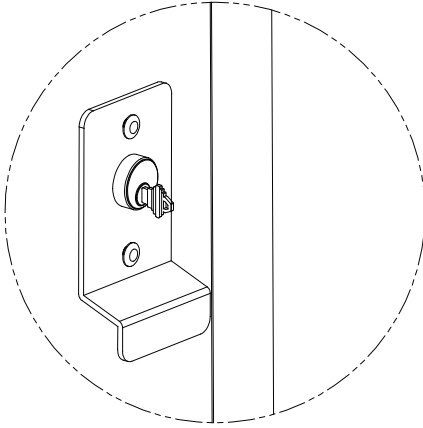

Key should turn smoothly.

If binding occurs, check the following:

1. For hollow metal doors, adjust for door compression.
2. Verify cylinder tailpiece length.
3. Verify tailpiece and cam engagement

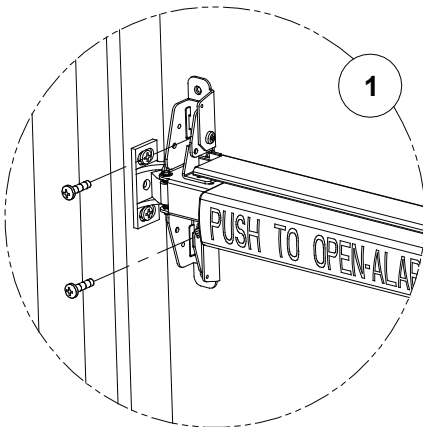

Adjust screws to relieve door compression.

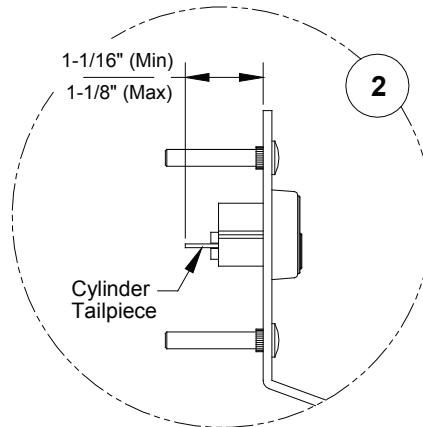

Verify cylinder tailpiece length.
(Shorten tailpiece if necessary)

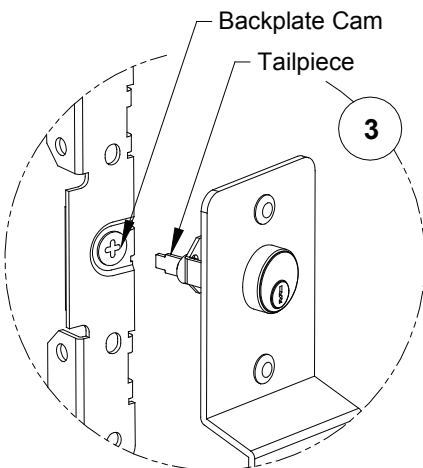

Verify tailpiece and cam engagement