

CLUBHOUSE CELLULAR PVC DECKING

Installation Instructions



Clubhouse Cellular PVC Decking features Korelite™ and SunShield® technology with performance in mind. Clubhouse Cellular PVC Decking should be installed using the same building requirements used for wood or composite decking and should adhere to local building codes. Clubhouse Cellular PVC products meet and exceed the acceptance criteria for the Universal Building Code's CCRR Tested in Compliance with ICC AC-174 Requirements, ATI Report #95796.01, and CA SFM Intertek Report #3195900SAT-001.

Storage and handling

Although all Clubhouse Cellular PVC Deck planks are made with low maintenance materials, each plank should be handled with care to ensure lasting beauty.

- Store under cover to maintain a clean surface
- Store flat and on a dry surface
- Stack units with banding and bottom supports aligned
- Never dump Clubhouse Cellular PVC Deck planks when unloading
- Always carry the plank on edge for better support
- Do not slide planks against each other or drag equipment including tools across the top of the planks
- During construction keep the surface of planks clear of waste and debris

Tools required

Clubhouse Cellular PVC Deck planks require no special tools for installation. The following is a list of standard tools required:

- Variable speed drill
- 3/16" drill bit
- Plate joiner (for use with hidden fastener system)
- Circular saw with carbide-tipped blade
- Jig saw
- Tape measure
- Framing square
- Pencil
- Safety glasses
- Rubber mallet

Because of the density of the Clubhouse Cellular PVC plank, nails and nail guns are not recommended.

Ventilation is required

To reduce moisture build-up beneath the deck there must be unobstructed continuous airspace of the deck to allow for proper ventilation.

- The use of lattice panels are permitted as long as the lattice openings are at least as wide as the lattice slats.
- Clubhouse Cellular PVC deck planks should never be used for roof applications, directly on top of or attached to a cement slab or installed directly in contact with the ground.

Failure to provide adequate ventilation may result in damage to the product and will void the warranty.

Joist spacing for new and existing frames

For both new and existing deck frames, use the following guidelines for joist spacing prior to installing Clubhouse Cellular PVC Decking. **IMPORTANT:** Clubhouse Cellular PVC Decking is a load bearing material but should **NEVER** be used for structural framing. Consult your local building codes for specific information.

- For proper installation, joist system must be level.
- Residential installations: 5/4" plank up to 16" on center. For diagonal installations reduce the span by 4".
- Commercial installations: Review local building codes for framing requirements.
- Stairs: 5/4" plank up to 12" on center.
- To aid in water run-off, the deck should slope 1/2" for every 8' away from structure.

Traditional screw down installation

We recommend surface screws designed for dense cellular PVC decking. Hand nailing is not recommended due to the density of the product. Always refer to the fastener manufacturer's recommendations and warranties to determine the best one for the job. Always choose fasteners that have an ACQ rated finish and one that is guaranteed by the fastener manufacturer. Fasteners must also comply with ASTM A153 or current code.

Note: Be sure to test screws on a scrap piece of Clubhouse Cellular PVC Decking prior to installation.

Clubhouse Screw Color Charts

Hardwoods				
Manufacturer	IPE	Walnut	Mahogany	Ironwood
Dexter Swan	Tan	Kona	Jatoba	Gray
Split Stop Titan III	Hickory/Cedar	Dk. Brown	Redwood/Dk. Brown	Gray
Composi-Iok Simpson Strong Tie	Tan	Redwood	Redwood	Gray
DeckFast Starborn	Cedar	Chocolate	Burgundy	Gray

Earthtones				
Manufacturer	Brookstone	Cobblestone	Sandstone	Clay
Dexter Swan	Lt. Gray	Mocha	Almond	Khaki
Split Stop Titan III	Gray	Cedar	Cedar	Cedar
Composi-Iok Simpson Strong Tie	Gray	Tan	Tan	Tan
DeckFast Starborn	Gray	Sand	White	Sand

Other approved fastening systems include:

Clubhouse HF Biscuit, HID Fast, Tiger Claw TC-G with gun, CAMO, The Deck Clip

Here are some best practices:

- Pre-drilling is recommended for the best overall appearance with most fasteners.
- Always start the screw at a slower speed and maintain a steady speed and pressure. This allows the screw to cut into the plank, rather than merely burn or spin.
- Mushrooming is a term that refers to the “bubble” of material that forms around the screw head as the threads exhaust Cellular PVC plank material toward the surface, resulting in a mushroom-like appearance.
 - To avoid mushrooming pre-drilling is recommended, keep drill at a constant, steady speed until the fastener is completely flush or countersunk approximately 1/16".
- Temperature, humidity and the moisture of the substructure can affect how much a Cellular PVC plank mushrooms.

Because of the density of the Clubhouse Cellular PVC plank, nails and nail guns are not recommended.

Color patterns and variation of variegated Clubhouse hardwood decking

Clubhouse Hardwood Decking is designed with variegation and variation in color and patterns. For best results during installation it is recommended that multiple courses of planks be laid out prior to installation. The courses should be reviewed for desired effect. This process is most critical when installing boards from multiple bundles of material. Mixing colors and patterns will allow for the most realistic replication of true hardwood decking.

Screw down installation process:

1. Begin installing planks at the outside edge of the deck and work back toward the structure. Screws should not be placed closer than 3/4" from end or edge of plank.
2. Notch first plank to fit around any wood posts as necessary.
3. Install the first plank with color-coordinated Swaneze or like screws using two screws per plank, per joist. (See Figure 1.)
4. Continue installing planks across the joists, allowing a 1/8" gap between planks. Gapping allows for expansion of planks for proper water drainage. (See Figure 2.)

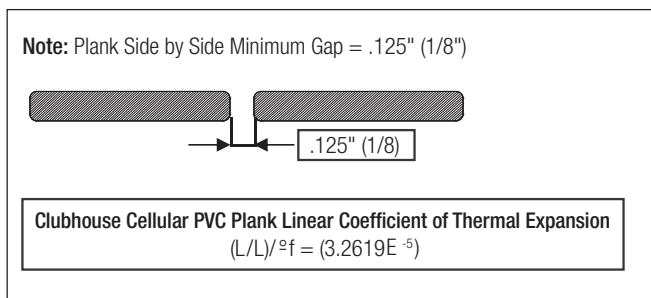

FIGURE 2

5. When butting planks end to end:
 - In temperatures 70° F or above, planks can be butted together without a gap. In temperatures between 32° and 70° F, planks should have a gap of 1/8" on each end. (Refer to Clubhouse Cellular PVC Total Expansion Value Chart on the Web site for areas where extreme temperature changes are possible.)

- Planks should only butt together over a joist or other proper support. It is recommended to use a double joist at butt ends. For the best appearance options, miter ends at 45 degrees or step overlap ends of the butt joint. (See Figure 3.)

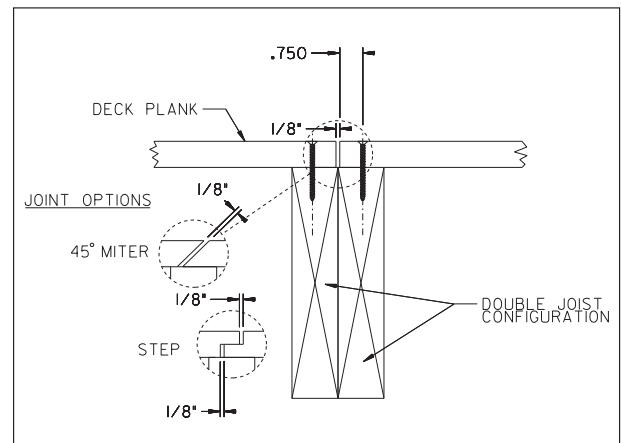

FIGURE 3

6. Always consult your local building code for application procedures.
7. Do not allow Clubhouse Cellular PVC planks to overhang more than 1-1/4" on all exposed sides of the deck.

Fascia installation

1. Measure and cut fascia to length, allow for a 1/8" gap between fascia planks and butt joints. (See Figure 4.)
2. Install fascia with matching color screws. (See Figure 1.) If using new, wet lumber pre-drill a hole that is slightly larger than the screw shaft to allow for contraction as the sub-structure dries.
3. Construction adhesives are sometimes used with cellular PVC fascia applications. You must check with the adhesive manufacturer to make sure their product may be used with Clubhouse Cellular PVC Decking and Fascia. Decuninck NV assumes no responsibility for the use of adhesives on their decking or fascia products.
4. Screws should be installed at a maximum of 16" intervals, 3/4" from edge and end of plank.
 - 10" width fascia use 3 fasteners evenly spaced
 - 6" width fascia use 2 fasteners evenly spaced
5. Never allow fascia to extend more than 1-1/4" below joist unsupported.

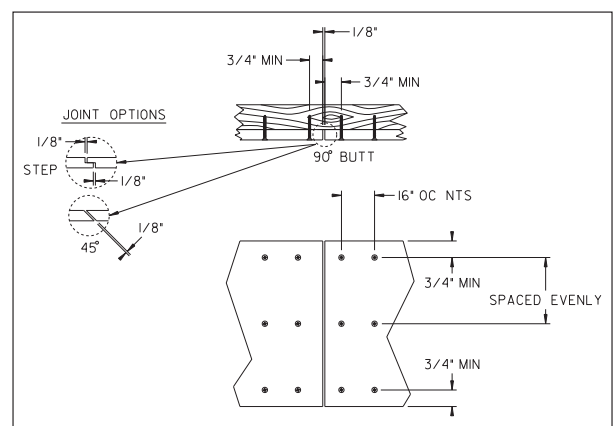

FIGURE 4

Hidden fastener system installation

Clubhouse Cellular PVC Hidden Fastener planks are designed to allow for easy installation – even by one person. No special tools are required to install the planks (see installation tools for a complete list). There are a number of hidden fasteners currently available today (including deck clips and biscuits) that have been used successfully to install Clubhouse decking, however you should always consult the manufacturer of the fastener to see if their product has been fully tested for use with Clubhouse decking. Deceuninck NV is not responsible for any failure that is a direct result of the hidden fastener.

Hidden fastener installation process

1. Install the first plank with color-coordinated screws. (See Figure 5.)
 - Install fasteners about 3/4" from the plank edge. Pre-drilling is recommended.
2. Place a hidden fastener in the deck plank groove, centered over each joist. (See Figure 6.)
3. Drive a 2-1/4" black head stainless steel screw flush to the top of each hidden fastener. The screw should drive straight into the joist, and **NOT** at an angle through the plank. Refer to hidden fastener manufacturer's recommendations. **Do not dverdrive.** (See Figure 7.)
4. Slide the next Clubhouse Cellular PVC plank over the exposed edge of the installed hidden fastener. The hidden fastener will automatically space each plank. Make sure the hidden fastener fully engages the plank. (See Figure 8.)



FIGURE 5



FIGURE 6



FIGURE 7



FIGURE 8

5. When butting planks end to end:
 - Planks should only butt together over a joist or other proper support. It is recommended to use a double joist at butt ends. Affix the hidden fastener as described in Steps 3 and 4.
 - In temperatures 70° F or above, planks can be butted together without a gap. In temperatures between 32° and 70° F, planks should have a gap of 1/8" on each end. (Refer to Clubhouse Cellular PVC Total Expansion Value Chart on the Web site for areas where extreme temperature changes are possible.)
6. Clubhouse Cellular PVC planks should not overhang more than 1-1/4" on all exposed sides of the deck.
7. Install the final plank with color-coordinated screws. (See *Swan Secure Products* for color match details.)
 - Because of the continuous groove, consider a technique using standard Clubhouse Cellular PVC screw down planks to frame the outer perimeter edge; use a plate joiner to cut biscuit grooves on one side, affix plank with color-coordinated screws. (See Figures 9 & 10.)

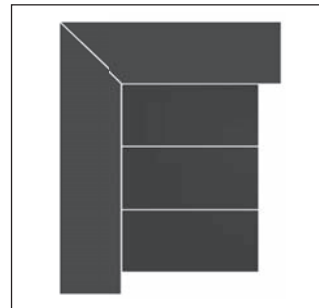

FIGURE 9

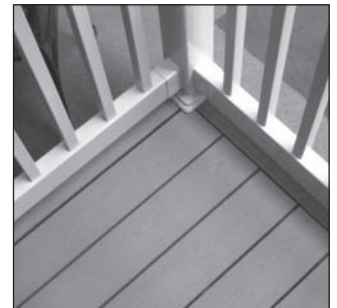

FIGURE 10

Helpful Tips

254 deck clips are required to build a deck which is a 100 square foot using a frame that is built 12" on center. 175 deck clips are required to build a deck which is 100 square foot when built 16" on center. (See Figure 11.)



EB-TY HIDDEN FASTENER BISCUIT
FIGURE 11

**CLUBHOUSE**[™]
DECKING

CLUBHOUSE CELLULAR PVC DECKING
Installation Instructions

Dirt, grime, mold and mildew stains

As with all outdoor products, common dirt and dust should be cleaned occasionally with a garden hose or soft-bristled brush. Clubhouse Cellular PVC Decking is a low-maintenance product, not a no-maintenance product. Clubhouse products are formulated to inhibit mildew growth and minimize staining. Even if it appears clean, it is important to prevent build-up of pollen/debris. Mildew stains may occur where moisture, pollens and/or dirt are present. Mildew needs a food source to grow, which can be grass, pollens and dirt.

Rust

Use a deck cleaner containing phosphoric acid and a commercial pressure washer (not to exceed 1100 PSI; see additional information below under power washing).

Caulking, tar, compounds and similar substances

Clean with mineral spirits in reasonable amounts, rinsing with water immediately.

Between deck planks

Use a plastic putty knife and gently clean between decking planks to clear debris.

Barbecue grills, chimeneas and portable fire pits

All sources of high heat should be placed on a non-rubber/non-vinyl grill mat or splatter guard to minimize stains. With any cleaning job that requires more than just water and a brush, we recommend that you try cleaning a small inconspicuous area or scrap piece of material before cleaning the entire surface area.

Power washing

Although not required, Clubhouse Cellular PVC Decking may be power washed with a gas or electric-powered spray hose. The level of the power washer should be set no higher than 1100 pounds per square inch (PSI). A fan tip nozzle should be used along with the proper cleaning product. Spray in the direction of the brush/grain pattern to avoid damaging the product. Use caution not to damage the material and always take the proper safety precautions when operating a power washer.

Snow and ice removal

Snow may be removed from deck surface using a non-metallic shovel. Sharp shovels that scrape or chip wood decks should not be used. While salt will not affect the structural integrity of Clubhouse, it may cause stains. If using salt to break up ice patches, remove salt as soon as possible to avoid stains and scratches. Do not use salt/ash mixtures.

Approved Cleaners

Most household type cleaners may be used on Clubhouse Cellular PVC Decking, however it is a good idea to test any intended cleaner on a small sample piece of material prior to using on the full deck. The following is a list of household cleaners that may be used:

- Fantastic[®]
- Murphy Oil Soap[®]
- Lestoil[®]
- Windex[®]
- Lysol[®]

Pools and spas

Clubhouse planks are designed to be used in conjunction with all outdoor living activity. Chlorinated water from pools and spas will not harm Clubhouse Cellular PVC Decking.

Docks and marine installations

Clubhouse Cellular PVC Decking is designed to withstand marine environments. It's the perfect choice for docks, boat slips and beach house decks.

Slip resistance

Clubhouse Cellular PVC Decking meets the Americans with Disabilities Act (ADA) Requirements.

Splintering and rotting

Clubhouse Cellular PVC Decking is guaranteed not to splinter or rot. It will not split when properly installed following the instructions provided.

Rubber or vinyl mats

The use of rubber or vinyl products such as door mats and catch mats under barbecue grills or other rubber or vinyl products is not recommended as these products may cause discoloration of the deck.