

# OPERATING INSTRUCTIONS

# NIR-50-325

## RETROREFLECTIVE PHOTOEYE

UL325-2018 MONITORED DEVICE



4564 Johnston Parkway, Cleveland, Ohio 44128

P. 800 426 9912 F. 216 518 9884

**Sales Inquiries:** [salesupport@emxinc.com](mailto:salesupport@emxinc.com)

**Technical Support:** [technical@emxinc.com](mailto:technical@emxinc.com)

[www.emxinc.com](http://www.emxinc.com)

# Contents

<b>Cautions and Warnings</b>	<b>2</b>
<b>Product Overview</b>	<b>2</b>
<b>Specifications</b>	<b>3</b>
<b>Configuration Settings and Wiring Diagrams</b>	<b>4</b>
<b>Indicators</b>	<b>5</b>
<b>Installation</b>	<b>5</b>
<b>Verification and Operation</b>	<b>6</b>
<b>Troubleshooting</b>	<b>6</b>
<b>Ordering Information</b>	<b>7</b>
<b>Warranty</b>	<b>7</b>

## Cautions and Warnings



1. ***Read and follow all operating and installation instructions.***
2. ***Always follow gate operator manufacturer installation instructions regarding installation of Type B1 sensor and operator.***
3. ***Disable the gate so it is unable to move.***

***Refer servicing to qualified service personnel.***

### **IMPORTANT:**

This product is an accessory or part of a system. Always read and follow the manufacturer's instructions for the equipment before connecting this product. Comply with all applicable codes and safety regulations. Failure to do so may result in damage, injury or death.



Retroreflective photoeyes rely on a reflective surface (a reflector) for proper operation. In some cases a vehicle with reflective surface at a given distance can act as a reflector and allow the gate to close on a vehicle.

EMX Industries Inc. assumes no responsibility in this case and all the risks are on the installer, designer and user of the gate system with a retroreflective photoeye. In case such a risk is not acceptable, EMX Industries Inc. strongly recommends the use of a thru-beam type of a photoeye.

## Product Overview

The NIR-50-325 retroreflective photoeye is an external entrapment protection device Type B1, non-contact sensor for use with automatic gates and doors. The light beam is pulsed near infrared. Since the reflector directs the beam back to the photoeye, wiring to the other side of the roadway is not required. The NIR-50-325 provides a signal to the gate or door operator that the beam is not obstructed. The operating range is up to 50ft. The NIR-50-325 operates over a voltage range of 12-30VDC and 24-30VAC.

Two LED indicators provide status information at a glance, making set-up and alignment easy. A yellow LED indicates signal stability. A red LED indicates alignment with reflector (off when obstructed).

The NIR-50-325 is configured for normally closed (NC) and 10k monitoring by the operator and complies with UL325 requirements effective August 1, 2018. The 10k termination resistor is built into the photoeye. Refer to operator manufacturer's instructions to ensure compatibility.

**Refer to operator installation instructions for proper monitoring selection.**

# Specifications

Specifications	
Operating range	0.5ft (0.1m) ...50ft (15.2m)
Sensitivity adjustment	Potentiometer
Signal stability indicator	Yellow LED
Alignment indicator	Red LED
Relay output	Form C contacts (NO, COM, NC) 30VAC/VDC, 2A
Resistive termination	10k $\Omega$ (internal)
Response time	10ms
Power (see Cautions and Warnings)	12...30VDC, 24...30VAC @ 60 Hz
Current draw	83mA
Operating temperature	-4°...131°F (-20°...55°C)
Environmental protection	IP 66 IEC
Dimensions (L x W x H)	1.3" (33mm) x 0.8" (21mm) x 2.6" (66mm)
Weight	0.2 lbs (91g),
Connections	5 wires, 6.5' (2m) cable
Certifications	CE, UL 325-2018

## Sensor Dimensions

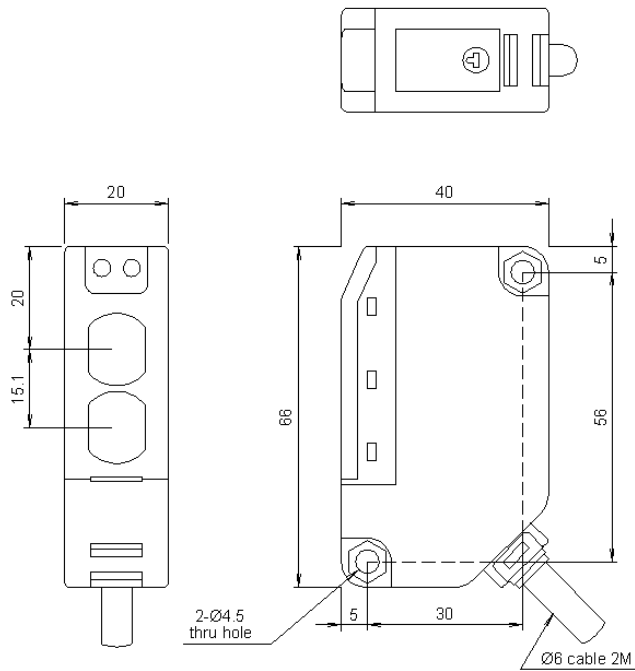

## Bracket Dimensions

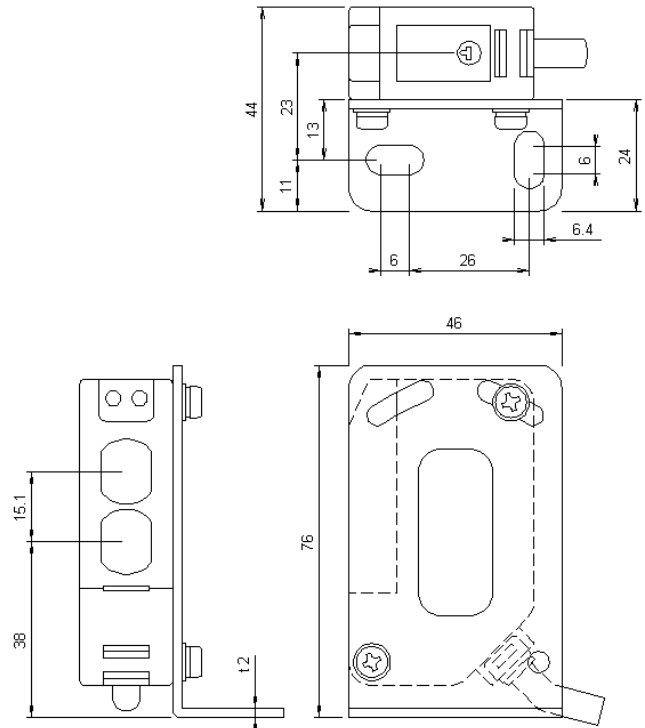

## REFLECTOR- O Dimensions

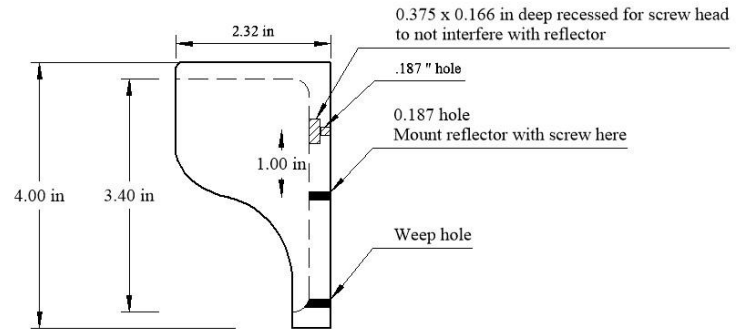
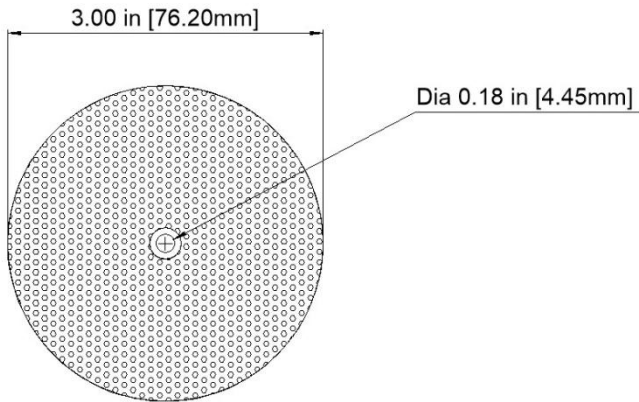

## NIR-HD Dimensions

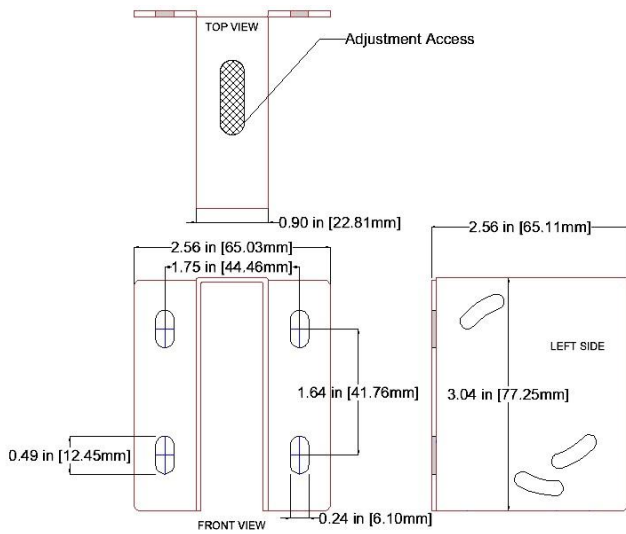

## Indicators

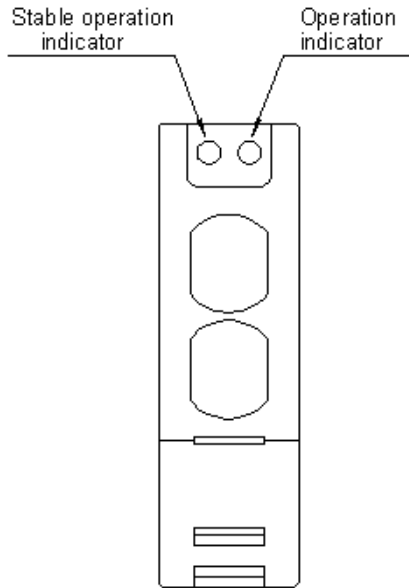

## Sensitivity Adjustment

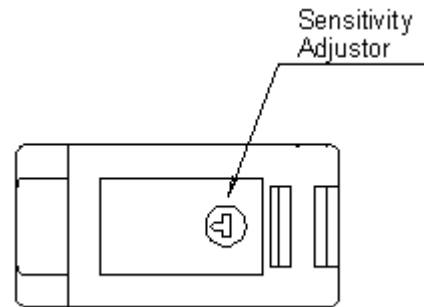

## Configuration Settings and Wiring Diagrams

Wire color	Description
<b>Brown</b>	Power input ( + )
<b>Blue</b>	Power input ( - )
<b>Gray</b>	Normally Open (NO) contact Relay output shown in energized state (power on, aligned with reflector, no obstruction)
<b>White</b>	Common (COM) contact
<b>Black</b>	Normally Closed (NC) contact Relay output shown in energized state (power on, aligned with reflector, no obstruction)

## Resistive

**NOTE: Remove power when wiring the unit**

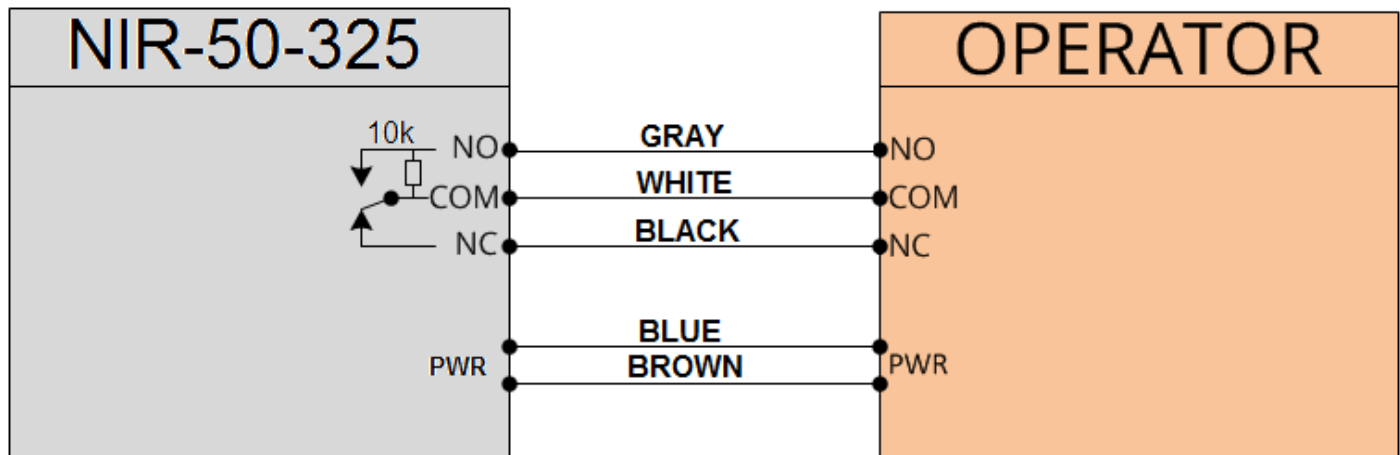

NOTE: The relay contacts on the board and the references to them in these instructions are shown in the energized state, aligned with reflector and no obstruction

## Indicators

### Indicator Definitions

Yellow	On	Unit is energized <u>and</u> signal is aligned and stable
Yellow	Off	Unit is off or signal is unstable
Red	On	Unit is energized and alignment is correct
Red	Off	Beam is obstructed or unit is not aligned with the reflector

## Installation



**Install the NIR-50-325 according to instructions from the gate operator manufacturer. The intent of External Entrapment Protection Device Type B1 non-contact sensor is to protect a person from being accidentally injured by the moving gate or door.**

1. Always follow the instructions of the gate operator manufacturer regarding installation of Type B1 sensors on the gate operator. The instructions of the gate operator manufacturer always supersede any instructions given in this or any other instructions by EMX Industries
2. When using the relay outputs, do not exceed the voltage/current ratings indicated in the specification table.

The recommended alignment technique is to mount the NIR-50-325 at the desired location and hold reflector about 3 feet in front of the unit while watching the lights to assure that both remain lit. Move backward to the desired mounting location for the reflector. You may have to move the reflector up, down, left or right to keep the reflector in the middle of the signal path. This ensures

the least troublesome setup by keeping the reflector off the edges of the signal where any movement may take it out of alignment.

NOTE: The signal pattern is only 2 feet in diameter

## Verification and Operation



**Verify proper operation of the NIR-50-325 according to instructions from the gate operator manufacturer. The intent of External Entrapment Protection Device Type B1 non-contact sensor is to protect a person from being accidentally injured by the moving gate or door.**

1. Verify that the NIR-50-325 and reflector are in line of sight and apply power. Confirm that the red LED and yellow LED are on, indicating power and proper alignment.
2. Place an obstruction (ex. hand) between the NIR-50-325 and the reflector. Ensure the yellow LED and red LED turn off. Check the operator control board and verify that the safety input is actuated.
3. Remove the obstruction and the yellow LED and red LED will turn on.
4. Follow gate/door manufacturer's installation instructions and safety checks to verify that the NIR-50-325 is operating properly.

## Troubleshooting

Symptom	Possible cause	Solution
Unit stays in detect	Unit out of alignment	Verify alignment
	Reflector covered with dirt, dust, snow, or water	Clean reflector surface of contaminants
	Water inside reflector	Replace reflector
No output	No Power	Check power and wiring as per chart on page 4 and 5
	Bad connection, wires broken	Check connections
	Improper wiring	Verify wired to correct inputs on operator
No detection	Unit not powered	Check power
	Other reflective surface causing signal return	Check surrounding area for reflective surface



## Ordering Information

<b>NIR-50-325</b>	<b>Retroreflective photoeye; includes mounting bracket with hardware</b>
<b>REFLECTOR-O</b>	<b>Reflector, 3" dia.</b>
<b>REFLECTOR-O-HD</b>	<b>Protective hood for reflector</b>
<b>NIR-HD</b>	<b>Protective hood for NIR</b>

## Warranty

EMX Industries Incorporated warrants all products to be free of defects in materials and workmanship for a period of two years under normal use and service from the date of sale to our customer. This warranty does not cover normal wear and tear, abuse, misuse, overloading, altered products, damage caused by incorrect connections, lightning damage, or use other than intended design.

There is no warranty of merchantability. There are no warranties expressed or implied or any affirmation of fact or representation except as set forth herein.

EMX Industries Inc. sole responsibility and liability, and the purchaser's exclusive remedy shall be limited to the repair or replacement at EMX Industries option of a part or parts found not conforming to the warranty. In no event shall EMX Industries Inc. be liable for damages, including but not limited to damages resulting from non-conformity, defect in material or workmanship.

Effective date: January 1<sup>st</sup>, 2002





4564 Johnston Parkway  
Cleveland, Ohio 44128  
United States of America  
[www.emxinc.com](http://www.emxinc.com)

Technical Support: (216) 834-0761  
[technical@emxinc.com](mailto:technical@emxinc.com)

Sales: (216) 518-9888  
Fax: (216) 518-9884  
[salesupport@emxinc.com](mailto:salesupport@emxinc.com)



Revision 1.4  
3-1-18