

SNUG COTTAGE HARDWARE (8292 OLD FASHIONED STRAP HINGE SPEC SHEET)

[www.snugcottagehardware.com](http://www.snugcottagehardware.com)

see accompanying Dimensions and Sizes Sheet

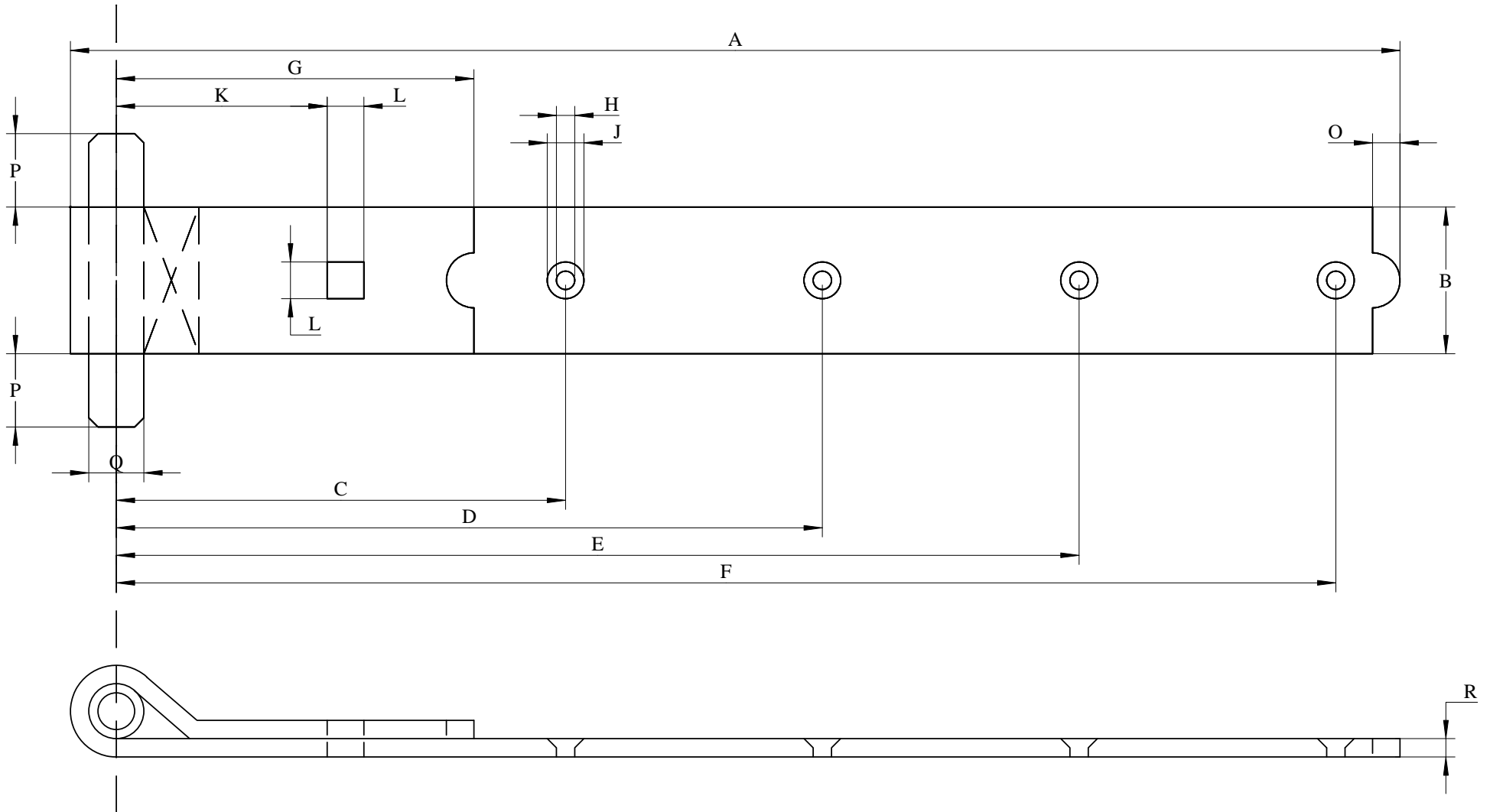

SNUG COTTAGE HARDWARE  
Old Fashioned Heavy Duty Hinges (8292)  
Dimensions and Sizes

Strap Length (inches)	DIMENSION (inches)														
	A	B	C	D	E	F	G	H	J	K	L	O	P	Q	R
7	7	1.5	6.125	NA	NA	NA	4	0.25	0.5	2.375	7/16" for 3/8" carriage bolt	0.375	0.75	0.5	0.1875
12	12	1.5	6	NA	NA	10.875	4.125	0.25	0.5	2.5	7/16" for 3/8" carriage bolt	0.375	0.75	0.5	0.1875
14	14	1.5	6.625	NA	NA	12.875	4.125	0.25	0.5	2.5	7/16" for 3/8" carriage bolt	0.375	0.75	0.5	0.1875
16	16	1.5	6	11	NA	15	4.125	0.25	0.5	2.5	7/16" for 3/8" carriage bolt	0.375	0.75	0.5	0.1875
18	18	2	6.75	11.625	NA	16.5	5.625	0.25	0.5	3.25	9/16" for 1/2" carriage bolt	0.5	1	0.625	0.1875
20	20	2	8.5	13.5	NA	18.5	4.875	0.25	0.5	3.25	9/16" for 1/2" carriage bolt	0.5	1	0.625	0.1875
24	24	2.25	7.5	15.5	NA	22.5	5	0.25	0.5	3.25	9/16" for 1/2" carriage bolt	0.625	1	0.625	0.1875
30	30	2.25	12.5	21	NA	29	5.375	0.25	0.5	3.75	9/16" for 1/2" carriage bolt	0.625	1	0.75	0.1875
36	36	2.25	12.5	21	28.75	34.75	5.375	0.25	0.5	3.75	9/16" for 1/2" carriage bolt	0.625	1	0.75	0.1875
48	48	2.75	11.125	23	34.75	46.5	5.375	0.25	0.5	3.75	9/16" for 1/2" carriage bolt	0.625	1	0.875	0.25

\* Screw hole locations are +/- 0.125 inches  
NA = Not Applicable for this size

12/8/2009

TOLERANCE - INP	METRIC
1 DEC PLACE	±.4 mm
2 DEC PLACE	±.1 mm
3 DEC PLACE	---
DRAFT = 5° U.O.S.	

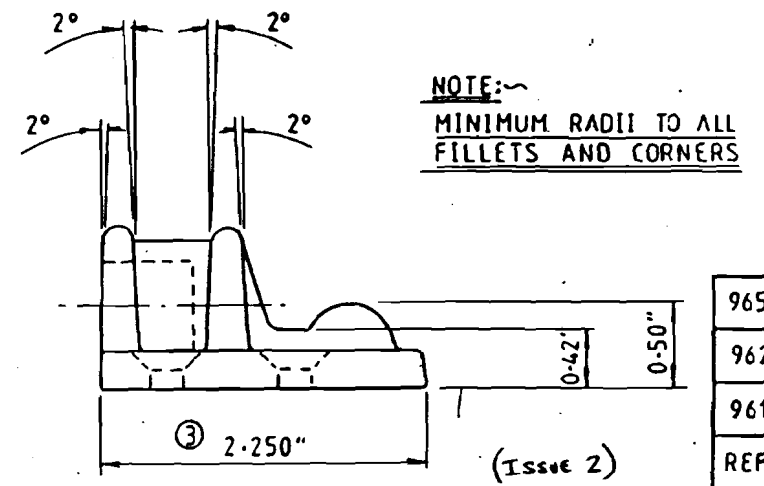
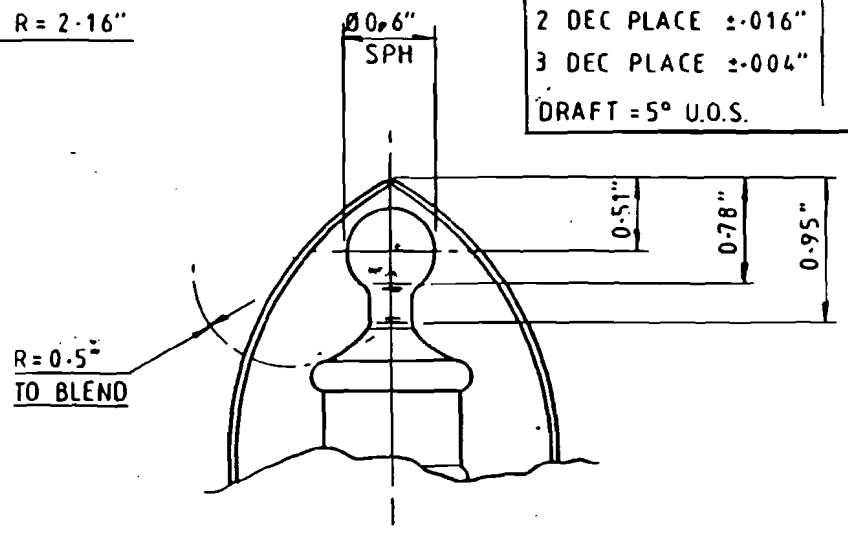
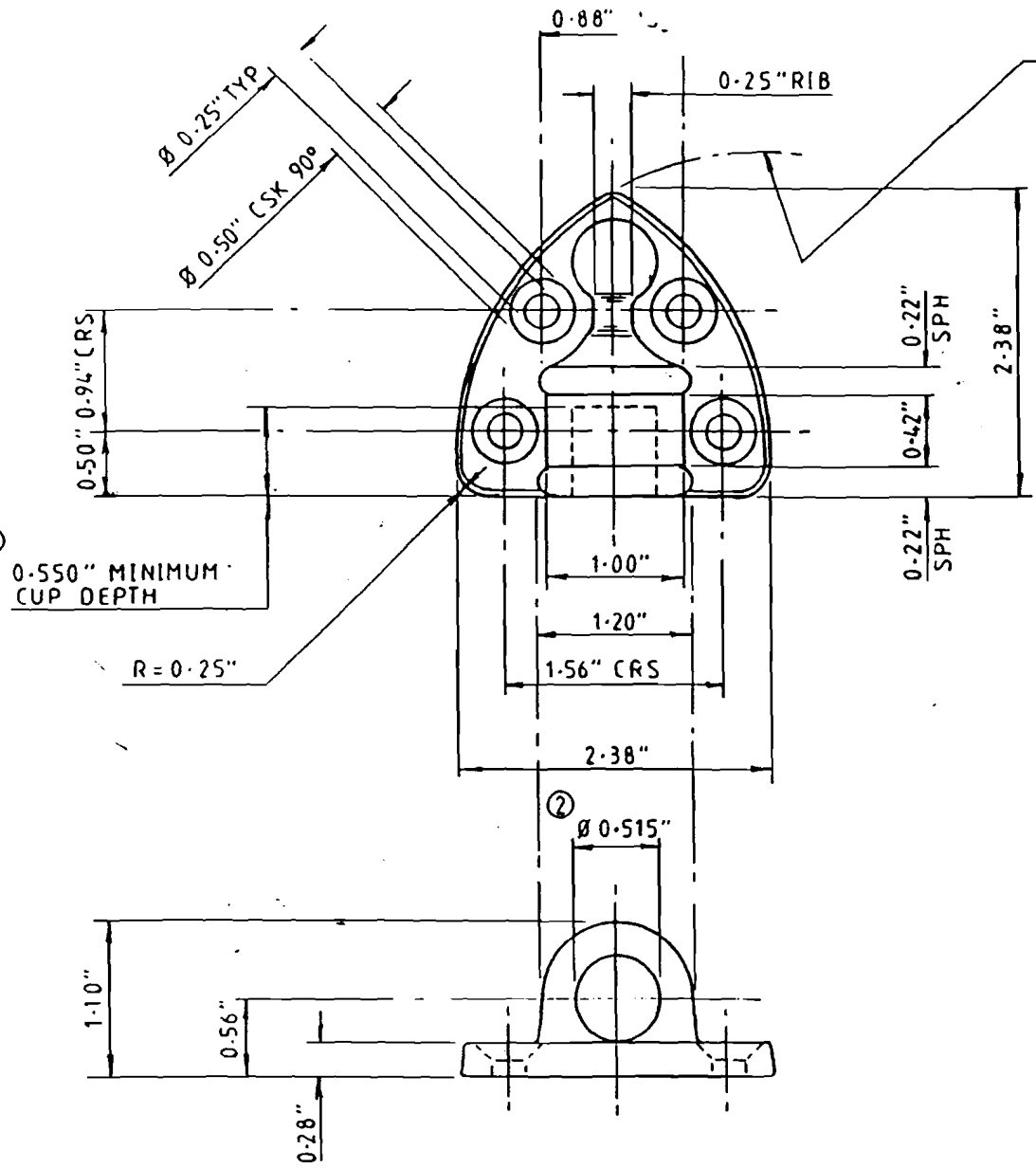

NOTE:~  
MINIMUM RADII TO ALL  
FILLETS AND CORNERS

965	SBM
962	GALV
961	SC
REF	FINISH

Snug Cottage Hardware  
Port Huron, MI 48060  
www.snugcottagehardware.com

TITLE  
"HEAVY REVERSIBLE HINGE  
CUP N° 2"  
For 7", 12", 14", & 16"

DATE 16/3/13  
DIA CHECKED  
DRAWN  
SCALE  
DO NOT SCALE

MATL  
MALL' CAST IRON  
FINISH  
SEE CHART  
TREATMENT

REF	DATE	REMARK
③	JAN'13	WAS 2.38"
②	JAN'13	WAS 0.56"
①	JAN'13	ADDED

DRG - 965  
- 962  
8292-961  
(SHT 3 OF 5)

TOLERANCE - IMP	METRIC
1 DEC PLACE	± .4 mm
2 DEC PLACE	± .1 mm
3 DEC PLACE	—
DRAFT = 5° U.O.S.	

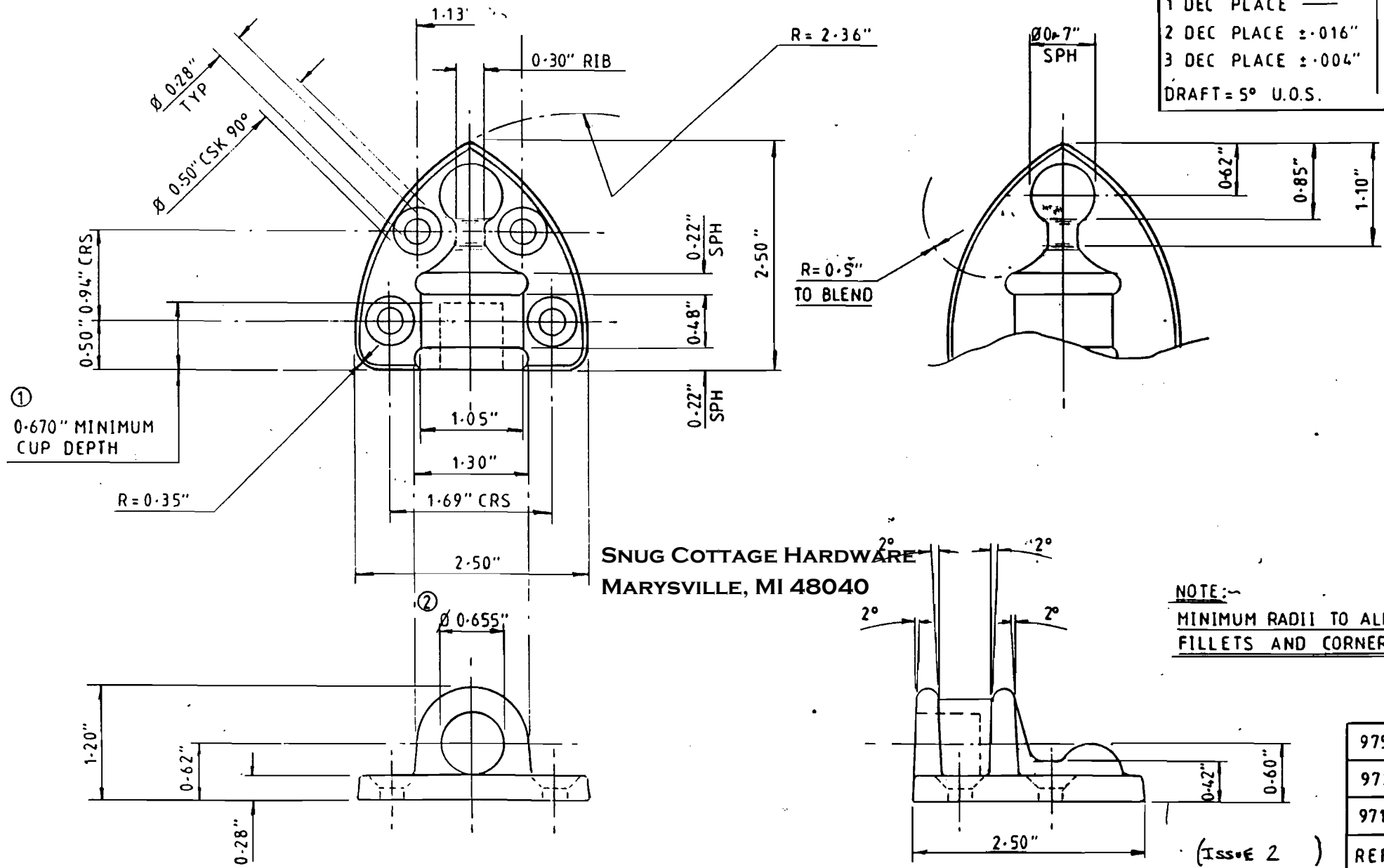

NOTE:~  
MINIMUM RADII TO ALL FILLETS AND CORNERS

975	SBM
972	GALV
971	SC
REF	FINISH

**Snug Cottage Hardware**  
 Port Huron, MI 48060  
 www.snugcottagehardware.com

TITLE  
**"HEAVY REVERSIBLE HINGE CUP N°3"**  
 From 18" 20" + 24"

DATE 10/1/93  
DIM CHECKED ✓  
DRAWN  
SCALE  
 DO NOT SCALE

MATL  
 MAL' CAST IRON  
FINISH  
 SEE CHART  
TREATMENT

②	Jan'93	WAS 0.68"
①	Jan'93	ADDED
REF	DATE	REMARK

DRG -975  
 -972  
**8292-971**  
 (SHT 4 OF 5)

TOLERANCE - IMP	METRIC
1 DEC PLACE —	±.4mm
2 DEC PLACE ±.016"	±.1mm
3 DEC PLACE ±.004"	—
DRAFT = 5° U.O.S.	

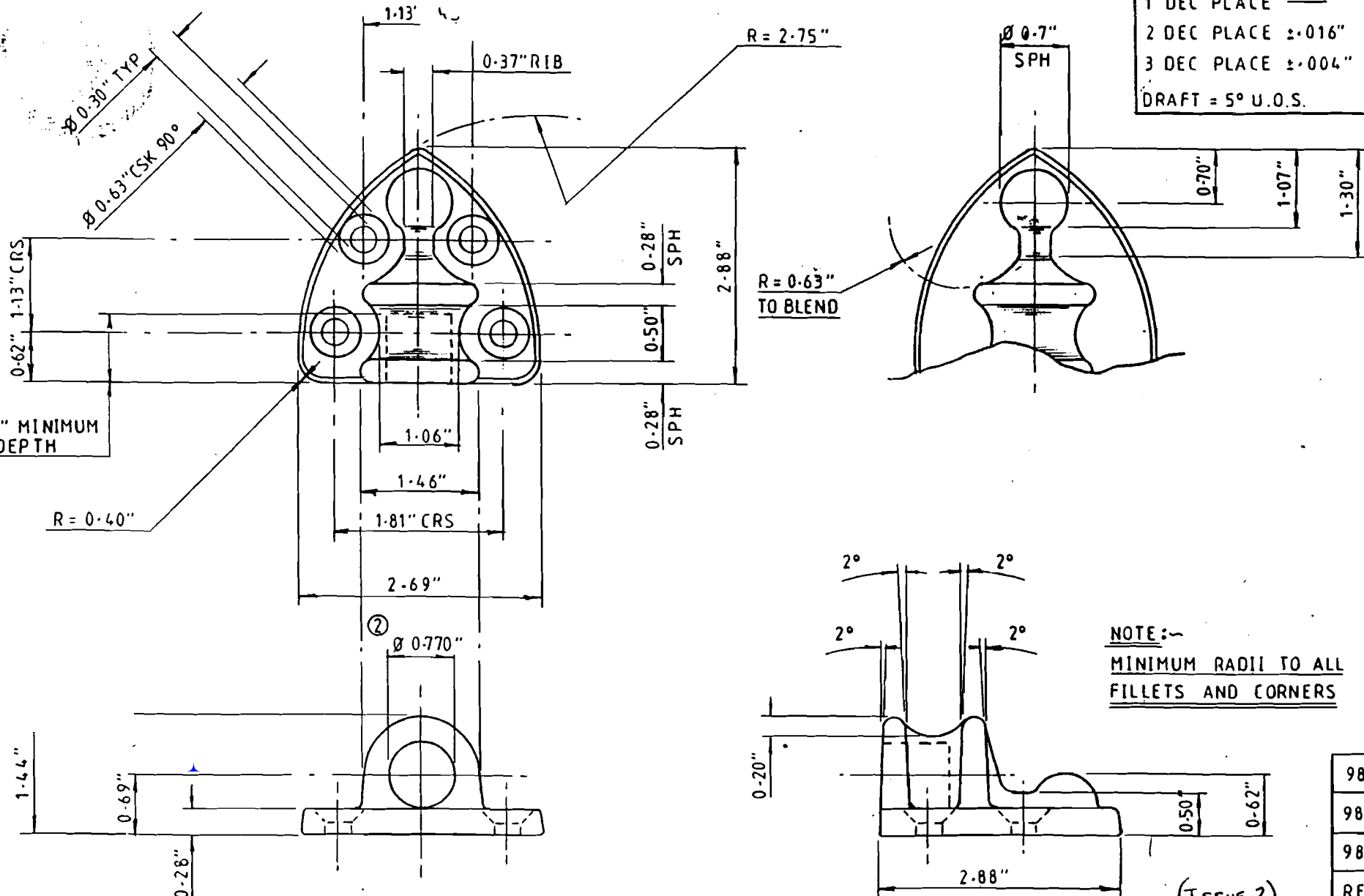

NOTE:~  
MINIMUM RADII TO ALL  
 FILLETS AND CORNERS

985	SBM
982	GALV
981	SC
REF	FINISH

**Snug Cottage Hardware**  
 Port Huron, MI 48060  
 www.snugcottagehardware.com

TITLE  
**"HEAVY REVERSIBLE HINGE  
 CUP N°4"**  
 For 30" x 36"

DATE 11/27/93  
 Dwn CHECKED *AK*  
DRAWN  
SCALE  
 DO NOT SCALE

MATL  
 MALL CAST IRON  
FINISH  
 SEE CHART  
TREATMENT

REF	DATE	REMARK
②	JAN'93	WAS 0.80"
①	JAN'93	ADDED

DRG -985  
 -982  
**8292-981**  
 (SHT 5 of 5)

(ISSUE 2)