

PART #	PACKAGING INSTRUCTIONS
NW6244-SD-FB	SHEET 2
NW6244-FB	SHEET 2

REVISIONS				
ECR/DCR	REV.	DESCRIPTION	DATE	APPD
-	-	INITIAL RELEASE	05/07/14	-

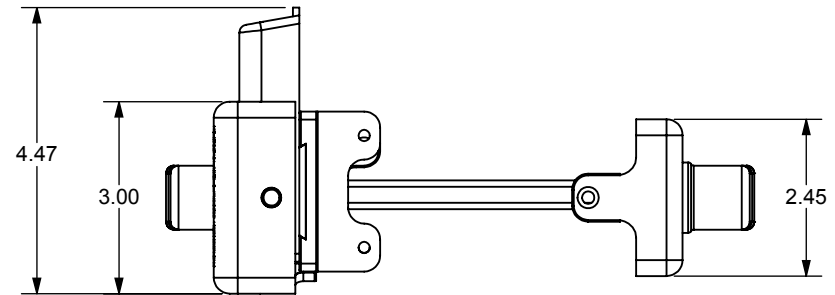
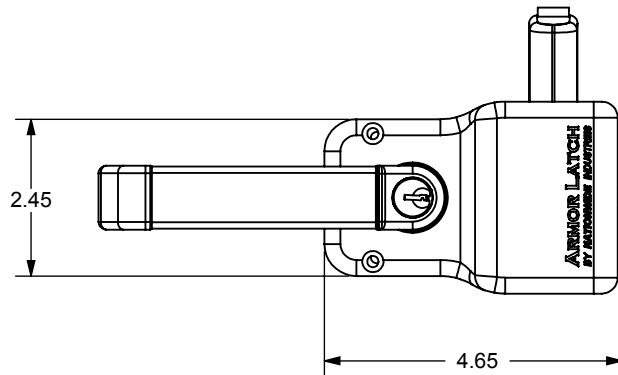
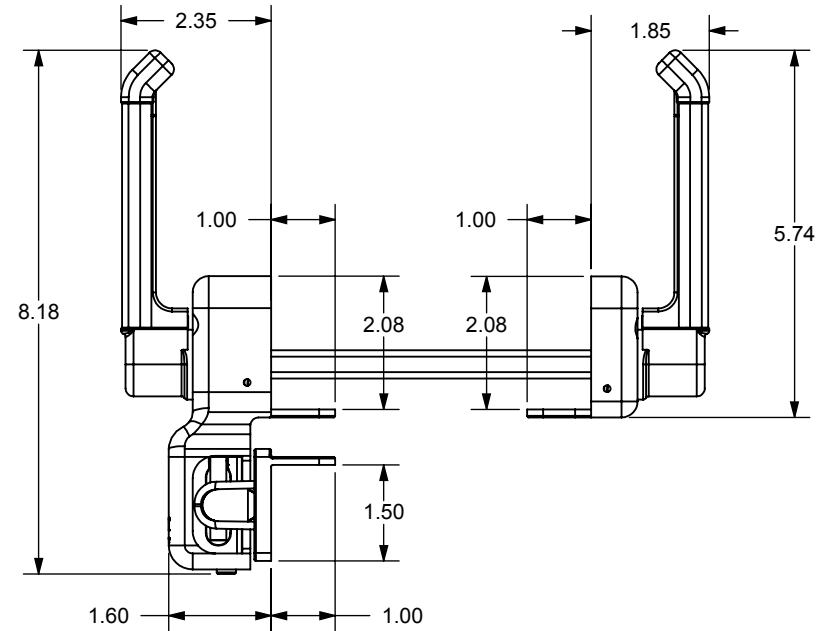
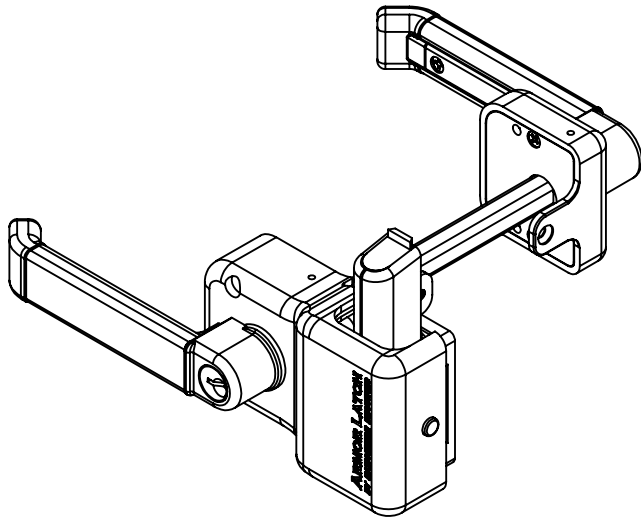

DIMENSIONS ARE IN INCHES
TOLERANCES:
FRACTIONAL $\pm 1/16"$
ANGULAR: MACH $\pm 1^\circ$ BEND $\pm 1^\circ$
TWO PLACE DECIMAL ± 0.01
THREE PLACE DECIMAL ± 0.005

PROPRIETARY AND CONFIDENTIAL
THE INFORMATION CONTAINED IN THIS DRAWING IS THE SOLE PROPERTY OF NATIONWIDE INDUSTRIES. ANY REPRODUCTION IN PART OR AS A WHOLE WITHOUT THE WRITTEN PERMISSION OF NATIONWIDE INDUSTRIES IS PROHIBITED.

NATIONWIDE INDUSTRIES

"ARMOR LATCH" MAGNETIC GATE LATCH

SIZE: **A** DWG. NO. **CS--NW6244** REV. **--**
SCALE: 1:3 WEIGHT: SHEET 1 OF 2

NW6244-SD-**

PACKAGING INSTRUCTIONS:

EACH INDIVIDUALLY LABELED BOXED SET TO CONTAIN:

1. INDIVIDUALLY POLYBAGGED

- (1) KEEPER ASSEMBLY
- (1) FRONT HOUSING ASSEMBLY
- (1) BACK HOUSING ASSEMBLY

2. POLYBAGGED MOUNTING HARDWARE KIT CONTAINING:

- (1) 5.95" HANDLE SPINDLE
- (1) 4.95" HANDLE SPINDLE
- (1) 2.95" HANDLE SPINDLE
- (1) 2.70" HANDLE SPINDLE
- (1) SET OF FRONT HOUSING KEYS
- (1) SET OF BACK HOUSING KEYS
- (1) INSTALLATION INSTRUCTION SHEET
- (1) "WARRANTY" SHEET
- (1) POLYBAGGED SCREW SET CONTAINING:
 - (2) #8 X 1.75" L PHILLIPS FLAT HEAD SELF DRILLING SCREW
 - (2) #8 X 1.25" L PHILLIPS FLAT HEAD SELF DRILLING SCREW
 - (6) #8 X .75" L PHILLIPS FLAT HEAD SELF DRILLING SCREW
 - (1) #8 X .5" L PHILLIPS FLAT HEAD SELF DRILLING SCREW
 - (3) 6-32 X .25" L PHILLIPS FLAT HEAD MACHINE SCREW

NW6244-**

PACKAGING INSTRUCTIONS:

EACH INDIVIDUALLY LABELED BOXED SET TO CONTAIN:

1. INDIVIDUALLY POLYBAGGED

- (1) KEEPER ASSEMBLY
- (1) FRONT HOUSING ASSEMBLY
- (1) BACK HOUSING ASSEMBLY

2. POLYBAGGED MOUNTING HARDWARE KIT CONTAINING:

- (1) 5.95" HANDLE SPINDLE
- (1) 4.95" HANDLE SPINDLE
- (1) 2.95" HANDLE SPINDLE
- (1) 2.70" HANDLE SPINDLE
- (1) SET OF FRONT HOUSING KEYS
- (1) SET OF BACK HOUSING KEYS
- (1) INSTALLATION INSTRUCTION SHEET
- (1) "WARRANTY" SHEET
- (1) POLYBAGGED SCREW SET CONTAINING:
 - (2) #8 X 1.75" L PHILLIPS FLAT HEAD SHEET METAL SCREW
 - (2) #8 X 1.25" L PHILLIPS FLAT HEAD SHEET METAL SCREW
 - (6) #8 X .75" L PHILLIPS FLAT HEAD SHEET METAL SCREW
 - (1) #8 X .5" L PHILLIPS FLAT HEAD SHEET METAL SCREW
 - (3) 6-32 X .25" L PHILLIPS FLAT HEAD MACHINE SCREW

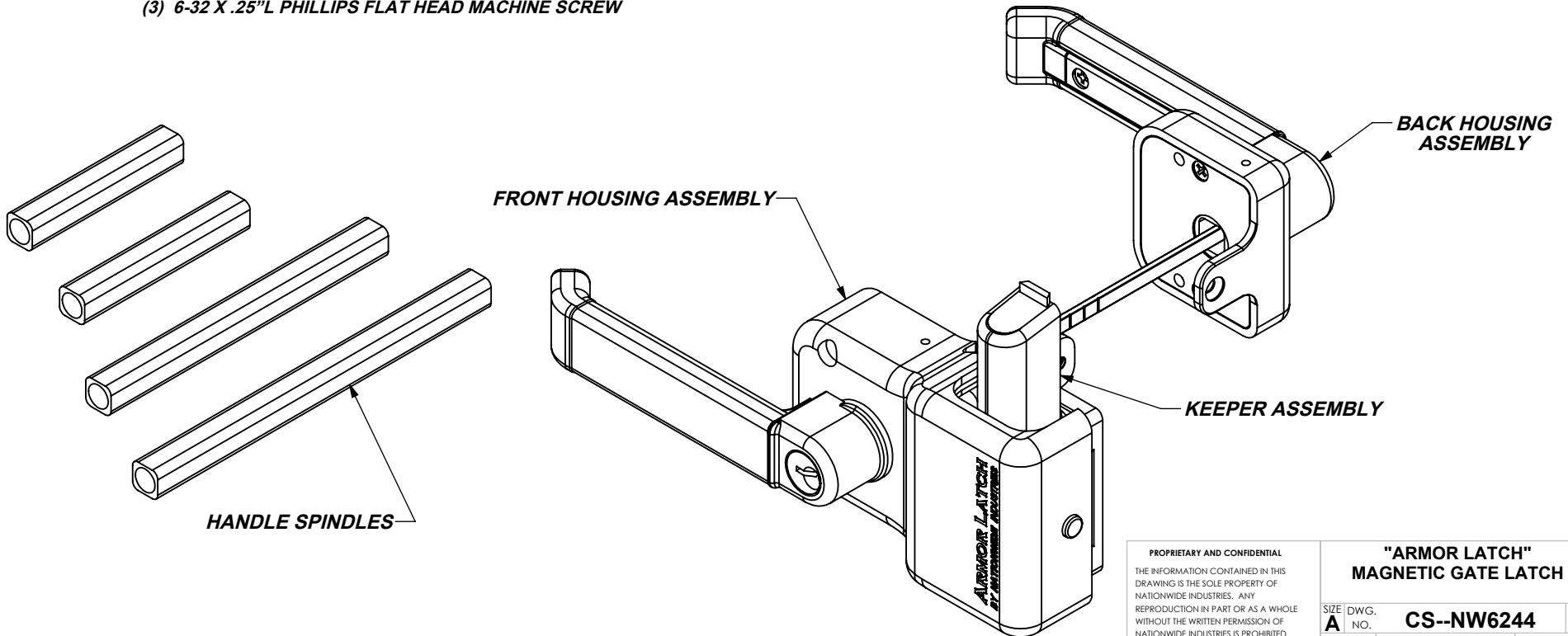

PROPRIETARY AND CONFIDENTIAL
THE INFORMATION CONTAINED IN THIS
DRAWING IS THE SOLE PROPERTY OF
NATIONWIDE INDUSTRIES. ANY
REPRODUCTION IN PART OR AS A WHOLE
WITHOUT THE WRITTEN PERMISSION OF
NATIONWIDE INDUSTRIES IS PROHIBITED.

"ARMOR LATCH"
MAGNETIC GATE LATCH

SIZE	DWG.	NO.	CS--NW6244	REV.	--
SCALE:1:4	WEIGHT:			SHEET 2 OF 2	