

Corner A Measure from the floor to the top of the bracket. Height should be railing height less 2 inches. Mark post and install brackets.

Align elbow so that there is equal distance from one side of the elbow to the existing railing, as with the other side.

Note: When installing railing into posts that have steel post brackets an aluminum insert is recommended for railing bracket installation. See lower step railing post illustration on back page.

Make sure that the elbow is flat, drill pilot holes and secure with screws.

Screw and Pilot Bit Recommendations:

Into Post (A, Step 1) Screw #14 x 1" into an aluminum insert using a 7/32" Pilot Bit or a #14 x 1 1/2" into wood using a 5/32" Pilot Bit - Phillips Bit P3
 Into Hand Rail (A, Step 3) Screw #14 x 1" - Pilot Bit 7/32" - Phillips Bit P3
 Into Connector (B, Step 3) Screw #10 x 1" - Pilot Bit 5/32", Countersink Drill 9/32", Square Drive #2 Bit

CORNER "A"

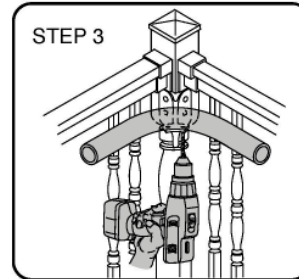
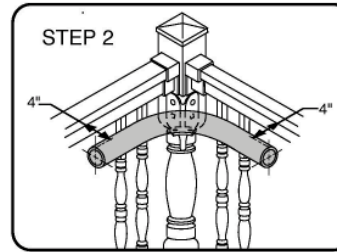
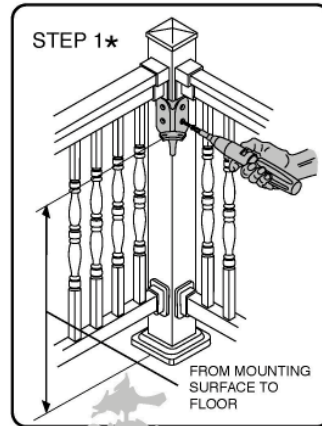

Corner B Install elbow using the same instructions as Corner A.

Hand Rail Measure distance between corners A and B (as shown). Add required pieces to corners using connectors. Pump pliers or vise grips can be used to fit connectors into the hand rail as well as tapping, as required, with a heavy rubber mallet. Final length may need to be cut for exact fit. Remove Corner B and fit together with handrail. Return Corner B to bracket and secure with screws.

CORNER "B"

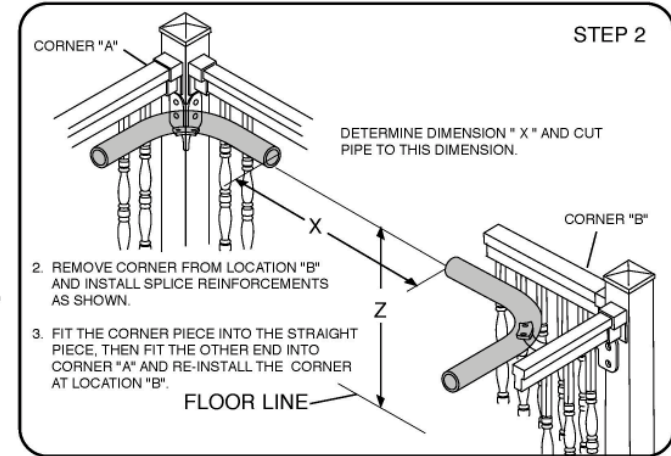
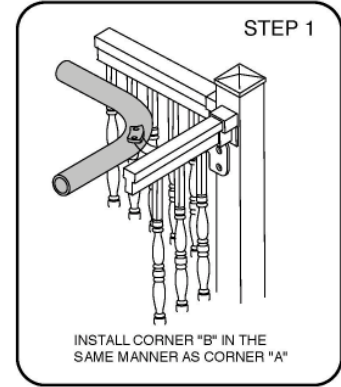

Where ever two ends of secondary handrail are joined, either to each other or to elbows, tighten the joint by drilling a 9/32" countersink and 5/32" thru hole and securing with screws. Make sure screw heads are smooth. (See next page, Finishing Connections)

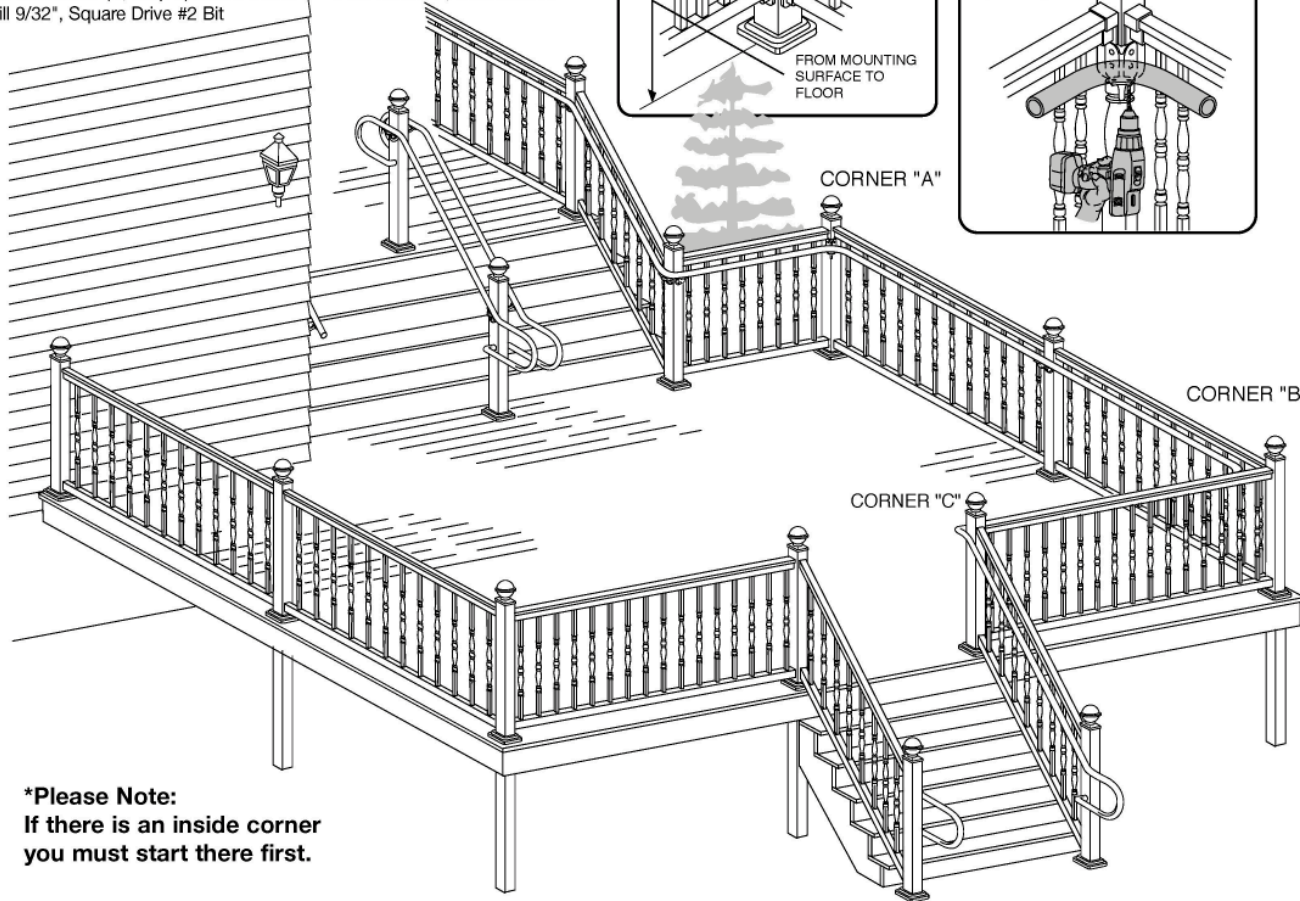
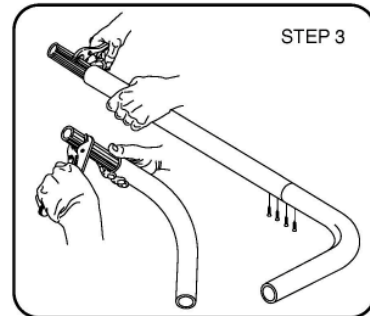

***Please Note:**
 If there is an inside corner you must start there first.

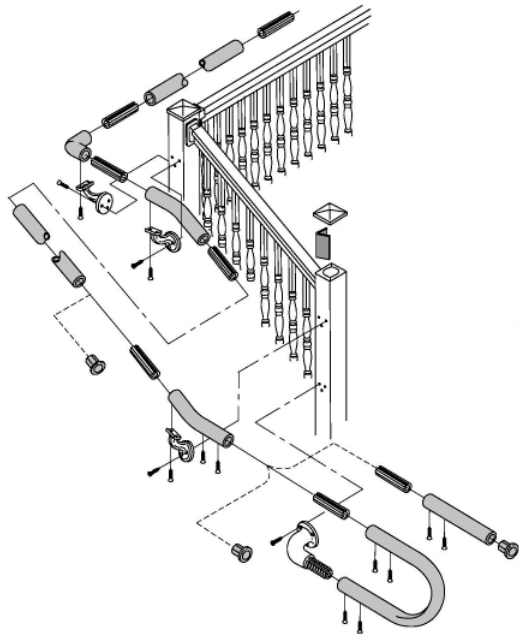

Finishing Connections

On bottom of railing use (2) screws on either side of a connector or (2) screws on a return.

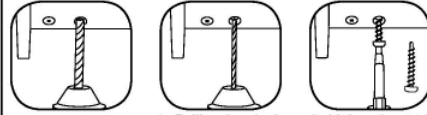

1. For each screw drill a counter sink the depth of the vinyl using a 9/32" bit.
2. Drill a thru hole using a 5/32" bit. *Do not rely on self drilling capabilities of the connector screws.*
3. Using the #10 x 1" connector screw provided, fully seat into the counter sink.

Determine the length to cut the handrail which is joined to the modified post return, by inserting the next piece of railing or elbow into the corner and laying it over the adjacent piece on the other side of the corner. This will establish a mark to cut the railing.

The post bracket must first be installed so that the piece inserted into the corner will lie on the bracket to establish a proper positioning.

Using a connector, join the corner with the railing cut in previous step and secure to the bracket as shown.

Secondary Handrail Components

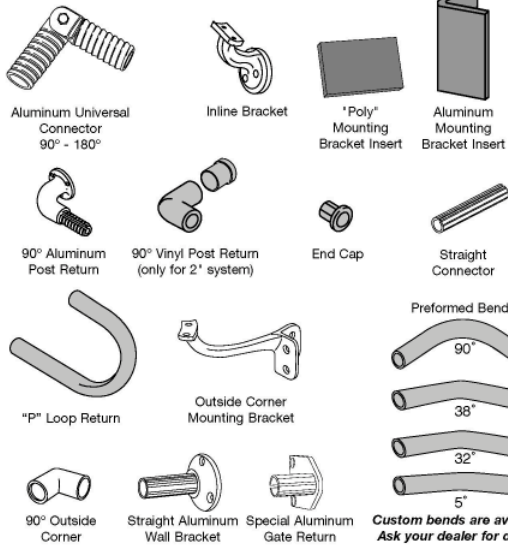

Custom bends are available. Ask your dealer for details.

"P" LOOP INSTALLATION

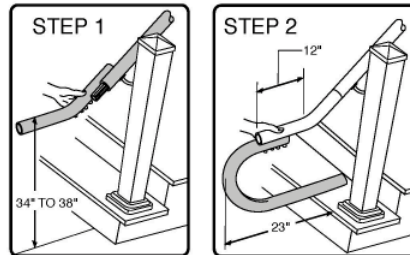

With corner now in place, determine the height of the in-line brackets on a step railing installation by holding a piece of railing in line with the elbow and parallel to the primary railing.

Typically, the secondary railing will be below the level of the primary railing. Install in-line brackets with screws, putting brackets on every post. Continue until ground level post is reached. At this point railing will be terminated in one of a number of ways: either by end capping a straight rail, end capping an elbow, or by using the "P" loop return to meet certain municipal requirements (see options, above).

01_2500

1 1/2" and 2" Secondary Handrail Installation Instructions

The 1 1/2" system complies with ADA Requirements. Properly installed, both systems exceed current ICC test requirements.

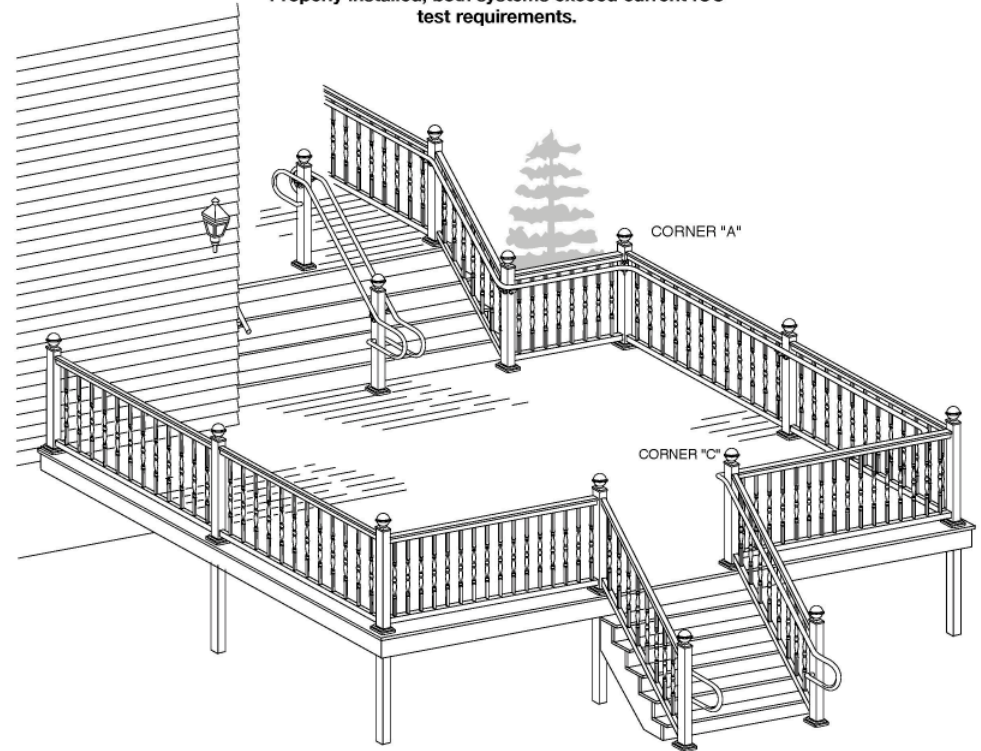

Sketch a layout of the new secondary railing in relationship to the existing railing noting the various pieces you will need and where you will need them. Check to see if you have all of the pieces that you will need.

Determine the height of the railing (35" to 38" to the top, for commercial applications) and check how that height works coming down or up steps.

Establish a place to begin. **NOTE: If there is an inside corner you must start there first.**